

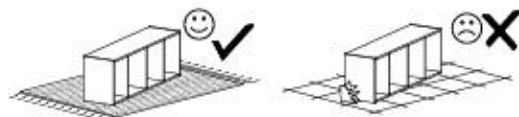

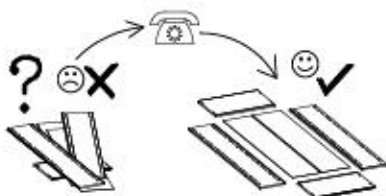

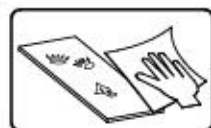

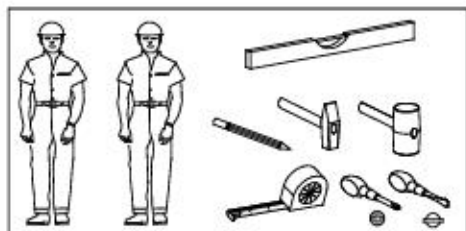
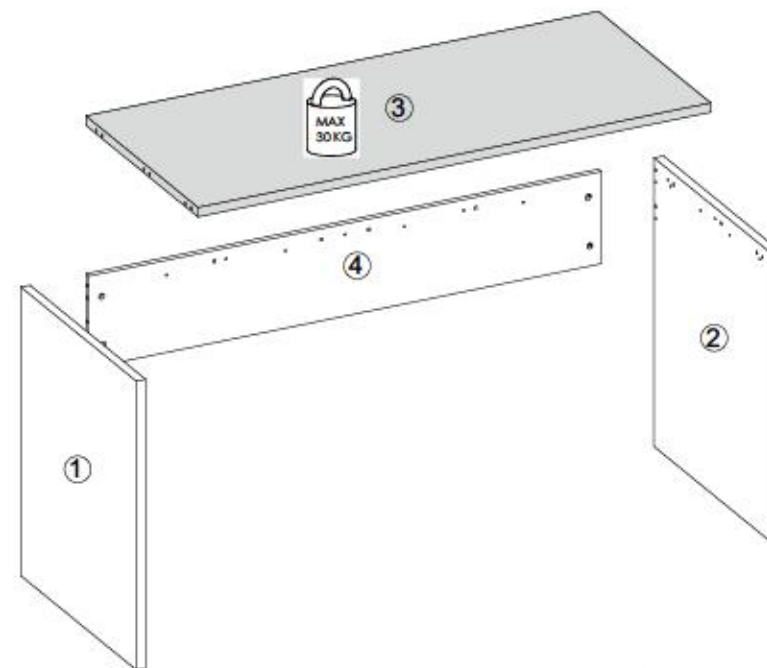

- Ⓛ Montageanleitung
- Ⓝ Handleiding voor de montage
- Ⓜ Montaj talimat
- Ⓧ Notice de montage
- Ⓢ Montážní návod
- Ⓟ Szerelési útmutató
- Ⓠ Assembly Instructions
- Ⓡ Instrukcja montażu
- Ⓡ Инструкции по монтажу
- Ⓡ Istruzioni di montaggio
- Ⓡ Návod na montáž
- Ⓡ Instrucțiuni de montaj
- Ⓡ Instrucciones de montaje
- Ⓡ Montaj Talimat



nr	L[mm]	B[mm]	T[mm]	Menge	Colt
1	762	622	25	1	1/1
2	762	622	25	1	1/1
3	1380	604	25	1	1/1
4	1380	280	16	1	1/1



W1  x3	B1  ø8x35 x16	I7a  x4	I7c  x9
K1  x13	K10  x13	P4  x4	F4  x12



I

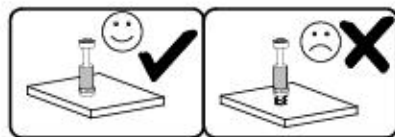
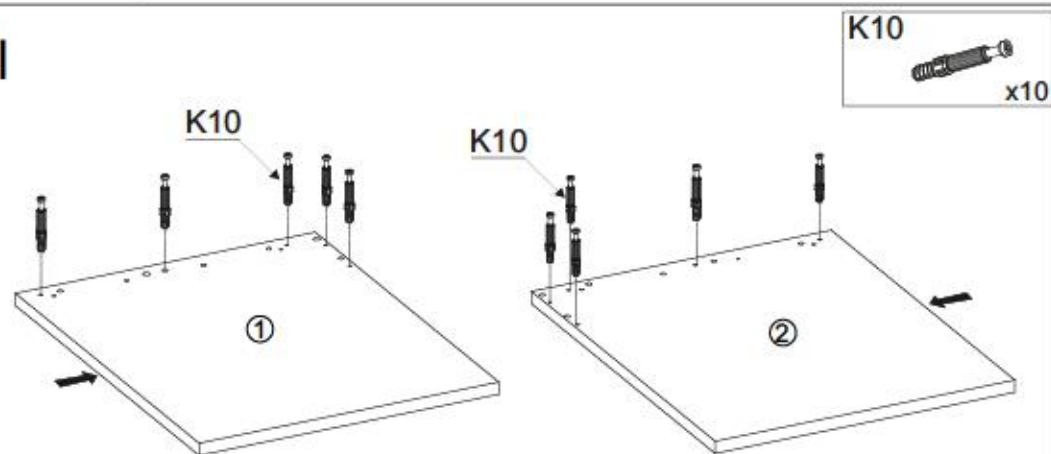

II

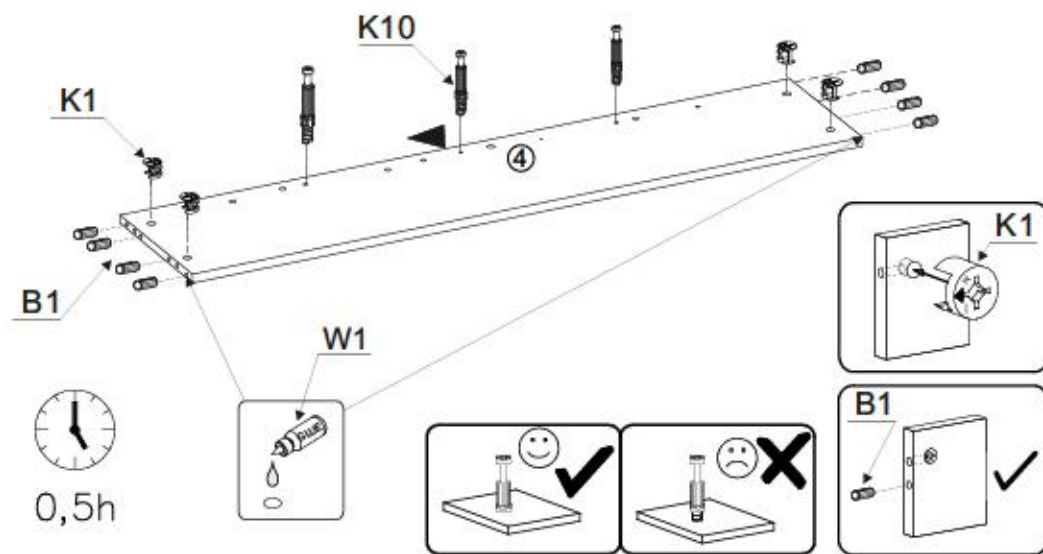

III

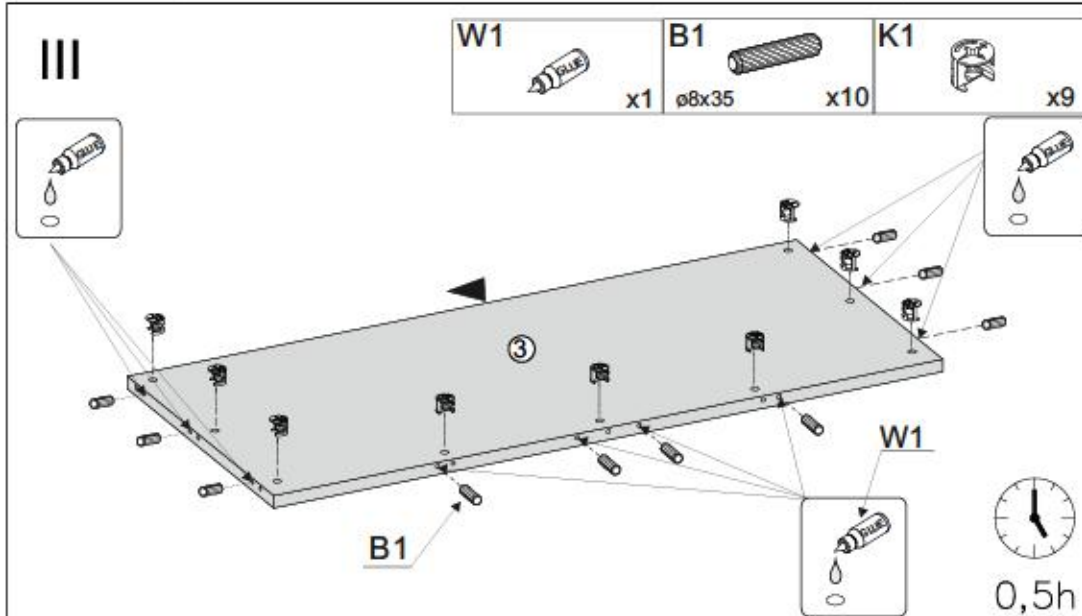

IV

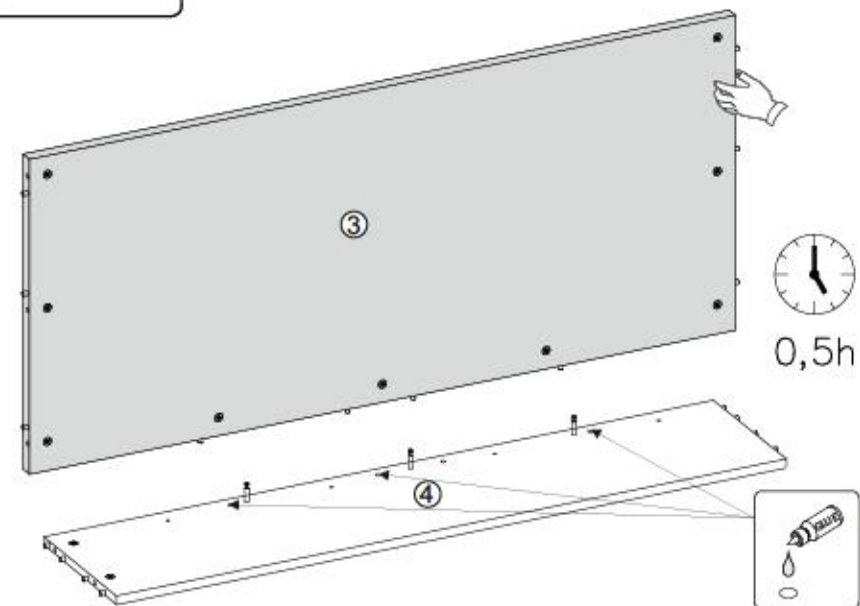
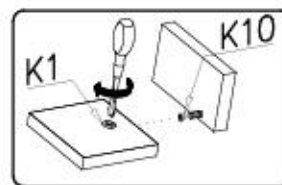



V

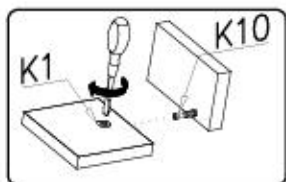

0,5h

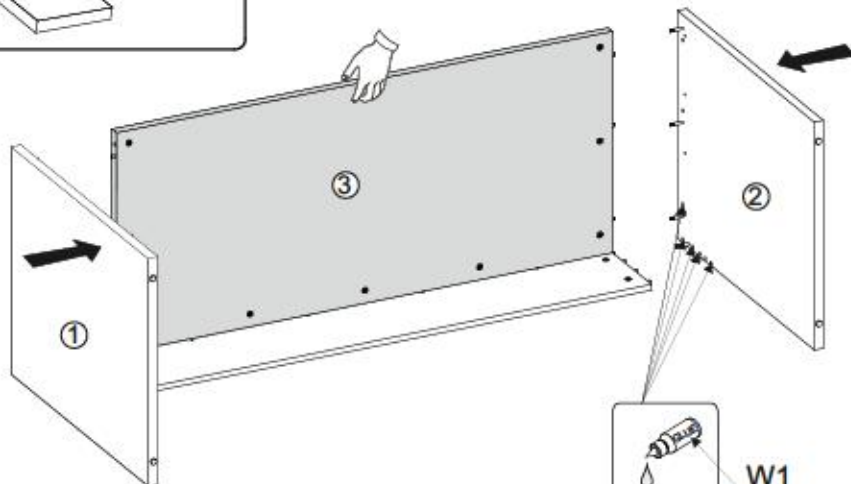

VI

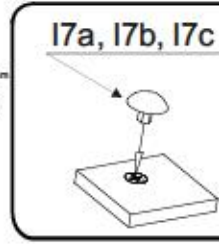
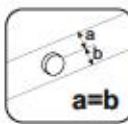
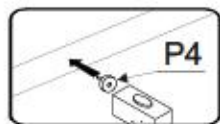
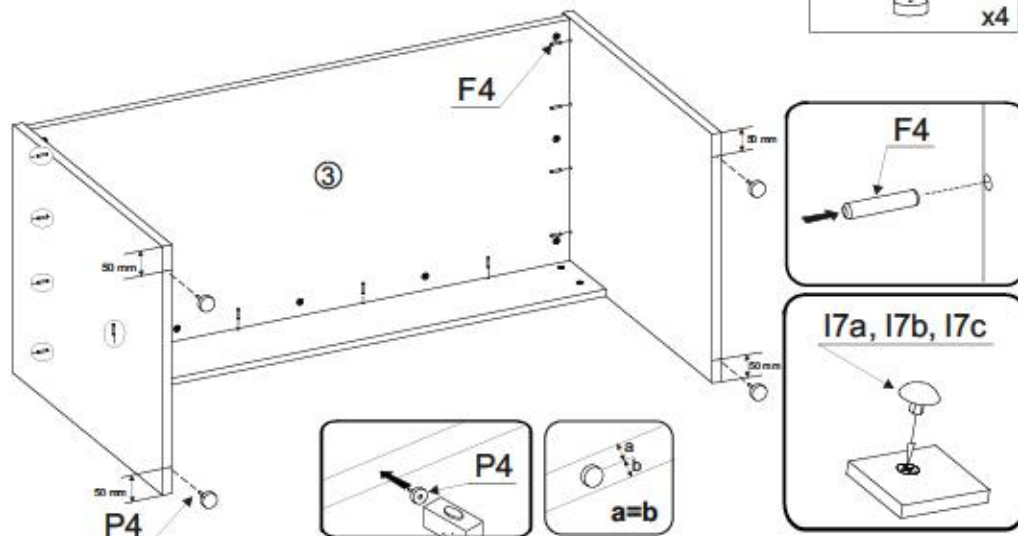
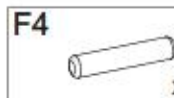
Name • Nom • Nome • Naam • Nazwa • Jméno
• Νόμος • Név • Denumire • Isim • Имя

CITY / GIRON

Nr • No • N° • Номер • Č • Sz

Typ • Type • Тип • Τύπος • Τύρο • Tun

06

D Linnor: Örtäcknings- & Beslaghjälp
Sollni Ihnen ein Beschlagsplatz fehlen, können Sie diese Servicekarte direkt an die untenstehende Adresse mailen. Wir können allerdings nur Beschlagteile auf diesem Wege versenden. Sollten Sie eine andere Bausatzung an Ihrem Möbelstück haben, so wenden sie sich bitte direkt an Ihr Möbelhaus.

GB Our direct order service for fitting
If a fitting part is missing, you can e-mail this service card directly to the address below. However, we can only send fitting parts in this way if you have any spare cause for complete covering your item of furniture, please contact your furniture store directly.

CZ Náš přímý služební servis
Chybí-li vám nějaký díl z kování, můžete tuto služební kartu odešlat e-mailem přímo na níže uvedenou adresu. Auto částku však můžeme poslat jen tímto způsobem. Pokud byste některou část kování měli, obraťte se přímo na svého prodejce nábytku.

F Bien vouloir nous écrire
Si vous manquez une ferrure, veuillez envoyer directement à l'adresse ci-dessous cette carte de service e-mail. Cependant, nous ne pouvons uniquement envoyer des ferrures. Pour tout autre type de réclamation concernant votre meuble, veuillez contacter directement votre magasin d'ameublement.

I Il nostro servizio diretto per i ordini della ferramenta
Qualora Vi dovesse mancare un pezzo di fissaggio, allora Vi preghiamo di inviare questa carta di servizio immediatamente all'indirizzo sottostante. Possiamo inviare i pezzi di fissaggio solamente per mezzo di questo procedimento. Qualora dovete avere qualche altra reclamazione in merito al mobile, allora Vi preghiamo di rivolgerVi direttamente al Vostro Negozio di mobili.

BG Наш директен сервис за монтаж
Ако ви липне част от монтажната част на мебела, моля да ни пишете директно на адреса по-долу. Можем да ви изпратим само частите за монтаж на мебела по този начин. Ако имате друга жалба относно мебела, моля да се свържете директно с вашия магазин за мебели.

NL Onze directie voor losse onderdelen
Wanneer er een onderdeel ontbreekt, kunt u deze servicekaart direct aan onze afdeling e-mailen. Wij kunnen in deze manier alleen losse onderdelen verzenden. Mocht u een ander probleem met uw meubel hebben, is contact op te nemen met uw meubeldealer.

PL Nasz bezpośredni serwis części montażowych
Jeśli w trakcie montażu brakuje części do montażu, prosimy o przesłanie nam niniejszej karty serwisowej na poniższy adres e-mailowy. Wzrostnie możemy przesłać części montażowe tylko w ten sposób. W przypadku innych reklamacji dotyczących mebla, prosimy o kontakt z naszym meblowcem, w którym został dokonany zakup.

HR Servis za otkove
U slučaju da nedostaje neki od dijelova potrebno vam da nas dođe uvidjeti mailom na adresu koju nalazite ovdje. Na ovaj način mogu se dostaviti samo otkovi. U slučaju da imate dodatne prigovore vezane uz kovanje namještaja molimo vas da se obratite bravaru trgovini namještaja gdje je isti kupljen.

HU Direktrendelési kártya használata esetén
Ha hiányzik egy vastag, acél a kovácsolt részekhez való illeszkedő acél alkatrészeket kérjük. Azonban csak a vastag részeket tudunk így küldeni. Amennyiben másféle problémát szeretne felvetni, kérjük, forduljon közvetlenül a boltiértelhez.

SK Náš priamy servis pre chýbajúce kovanie
Ak by Vám chýbala nejaká časť kování, môžete poslať túto služobnú kartu priamo e-mailom na nižšie uvedenú adresu. Cieľom kování vieme poslať iba týmto spôsobom. Ak by ste mali inú reklamáciu ohľadom vášho nábytku, obraťte sa priamo na vášho predajcu nábytku.

SLO Náš direktni službeni servis za otkove
Vse vam manjka kakih delov, lahko to sporočimo direktno po e-pošti direktno na spodnji naslov. Po tej poti vam lahko pošljemo samo otkove. Če želite kakršnokoli težavo drug del pohištva, se obrnite neposredno na vašo trgovino pohištva.

RO Serviciul nostru direct pentru fierare
In cazul in care va lipseste o piesa de fierare a pieselor puteti sa ne trimiti direct acest card de serviu prin e-mail la adresa de mai jos. Noi nu putem expedia piese de fierare decat pe aceasta cale. Dacă aveți o altă reclamație referitoare la piese de mobilier, atunci vă rugăm să vă adresați direct la magazinul dvs. de mobilier.

RUS Наш прямой сервис для крепежа
Если Вам не хватает какой-либо детали крепежа, пожалуйста, отправить нам эту карточку прямо по электронной почте на адрес, указанный ниже. Мы сможем доставить детали крепежа только таким образом. Если у Вас есть другая претензия по поводу мебели, пожалуйста, обращайтесь непосредственно к продавцу мебели.

S Vår direktservice för beslagdelar
Om du saknar en beslagdel kan du skicka detta servicekort direkt till e-postadressen som anges nedan. Tänk på att detta är den enda möjligheten att skicka beslagdelar till dig. Om du vill reklamera din möbel av annan anledning rekommenderar vi kontakt med möbelsälaren direkt.

ES Nuestro servicio directo para accesorios
Si le falta al algún accesorio, puede enviar este tarjeta de servicio directamente a la siguiente dirección. No obstante, por este método solo podemos enviar accesorios. Si tiene alguna otra objeción sobre su mueble, consulte directamente con su mueblería.

TR Doğrudan için donatılar servisi
Bir donatıya ihtiyacınız varsa lütfen kartımızı doğrudan aşağıdaki bu adresle donatılar bölümüne gönderin. Sadece bu yolla donatılar gönderilebilir. Diğer mobilya ile ilgili diğer problemlerinizi doğrudan mobilya satıcınıza bildirin.

nr	L [mm]	B [mm]	T [mm]	Menge	Cut
1	762	622	25	1	1/1
2	762	622	25	1	1/1
3	1380	604	25	1	1/1
4	1380	175	16	1	1/1

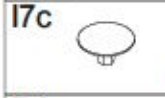
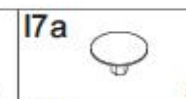
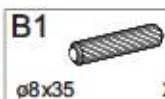
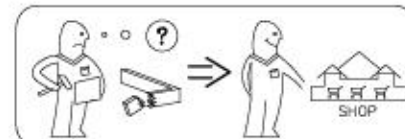
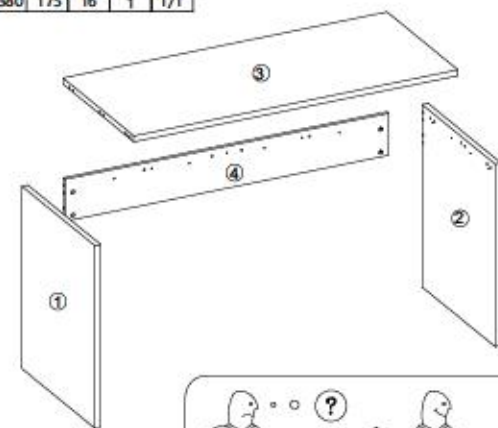

+49 5233 95 290 10

service@mv-steinheim.de

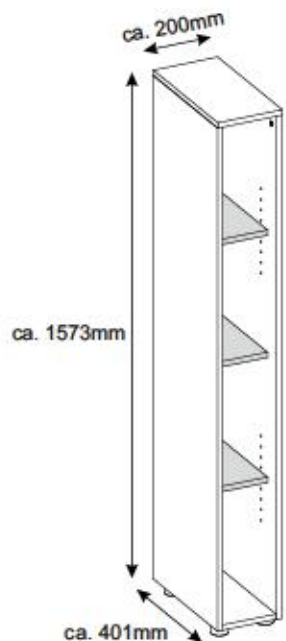

- Ⓓ **Montageanleitung**
- Ⓐ **Handleiding voor de montage**
- Ⓙ **Montaj talimat**
- Ⓕ **Notice de montage**
- Ⓒ **Montážní návod**
- Ⓗ **Szerelési útmutató**
- Ⓖ **Assembly Instructions**
- Ⓟ **Instrukcja montażu**
- Ⓡ **Инструкция по монтажу**
- Ⓣ **Istruzioni di montaggio**
- Ⓢ **Návod na montáž**
- Ⓡ **Instrucțiunile de montaj**
- Ⓔ **Instrucciones de montaje**
- Ⓙ **Montaj Talimat**

nr	L[mm]	B[mm]	E[mm]	Menge	Colt
1	1532	400	16	1	1/1
2	1532	400	16	1	1/1
3	200	401	16	1	1/1
4	166	378	16	1	1/1
5	166	325	16	2	1/1
6	166	325	16	1	1/1
7	1534	176	3	1	1/1

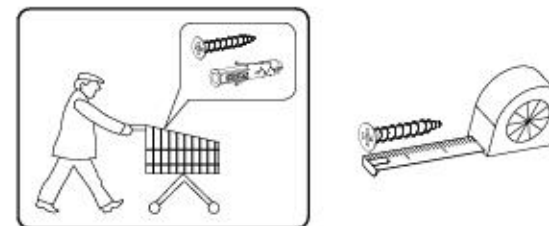
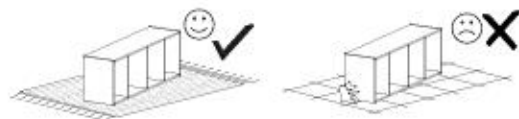
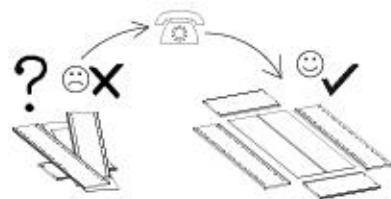
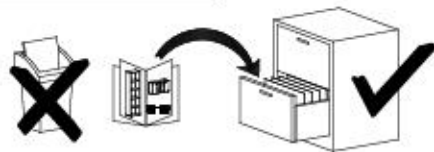
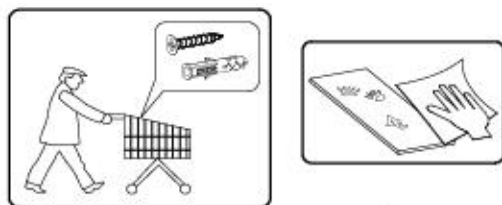
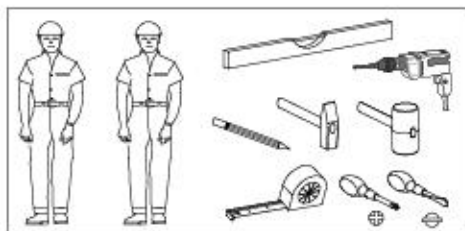
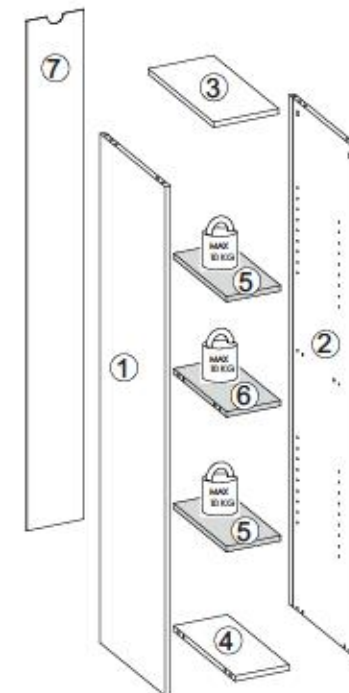

B1 ø8x35 x12	I7a x4	I7b x4	G36 4x30 x4	G34 3,5x16 x1
K1 x12	K10 x12	F4 x8	M11 x1	G50 3x20 x4
P10 x4				

3/11

CITY / GIRON 21



I

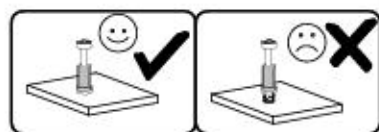
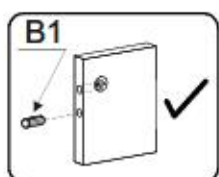
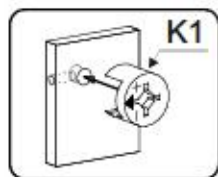
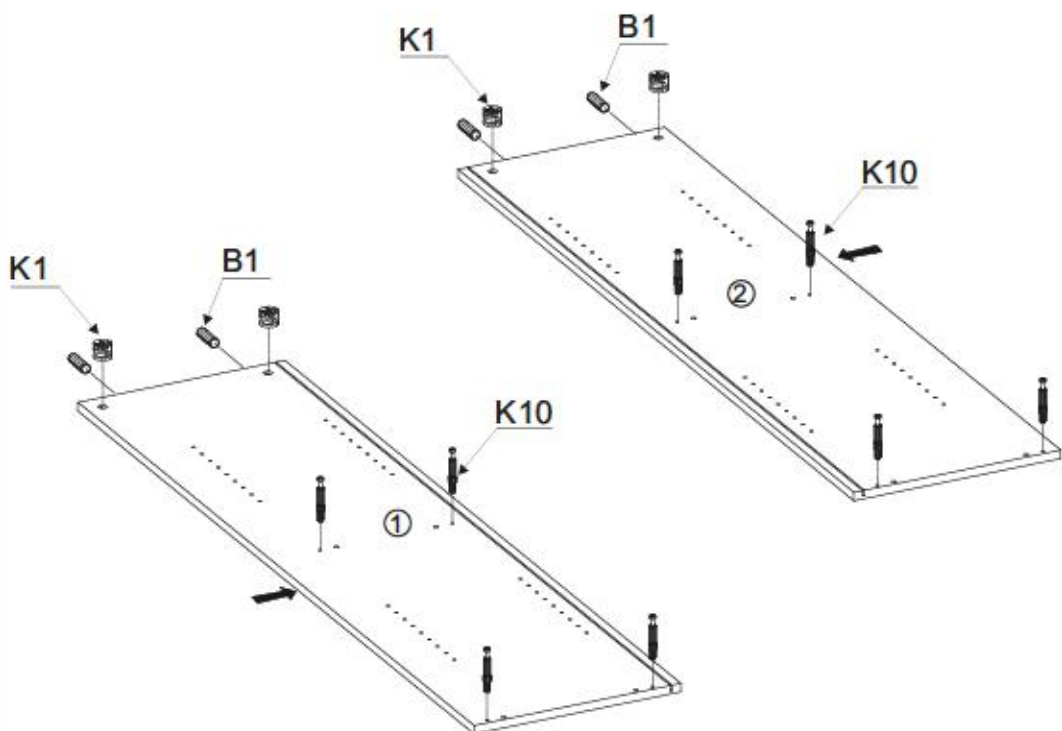
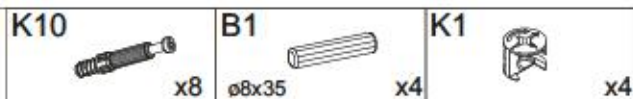

II

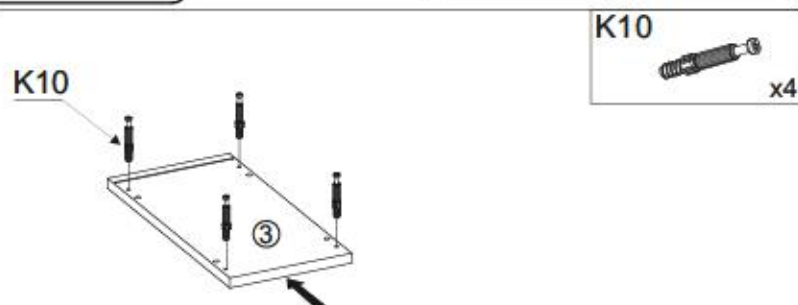

4/11

CITY / GIRON 21



III

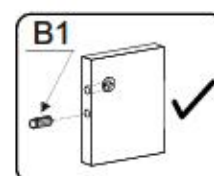
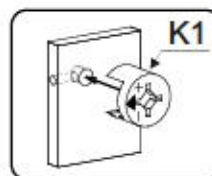
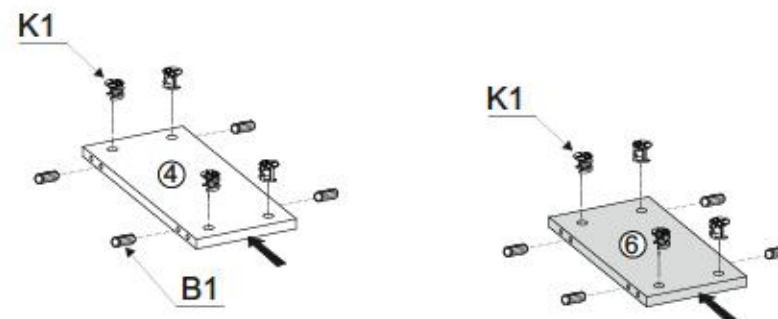
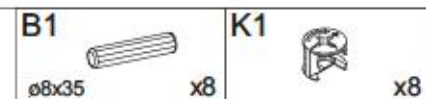

IV

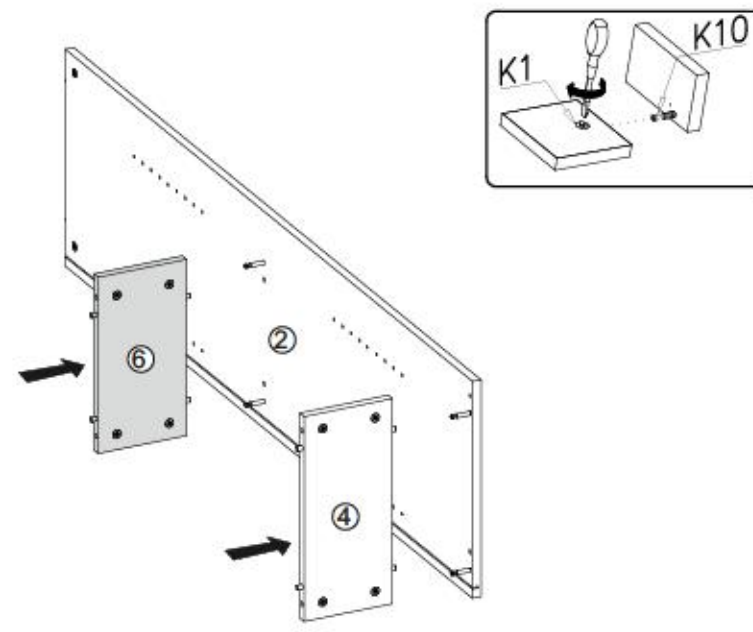
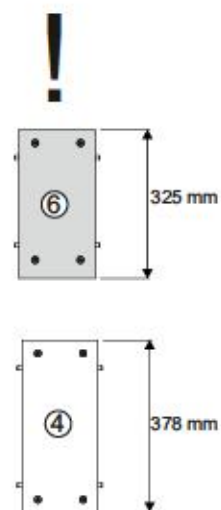



V

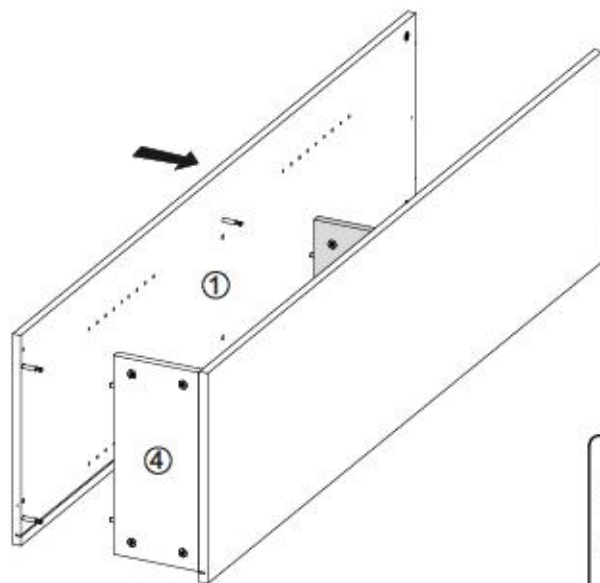

VI

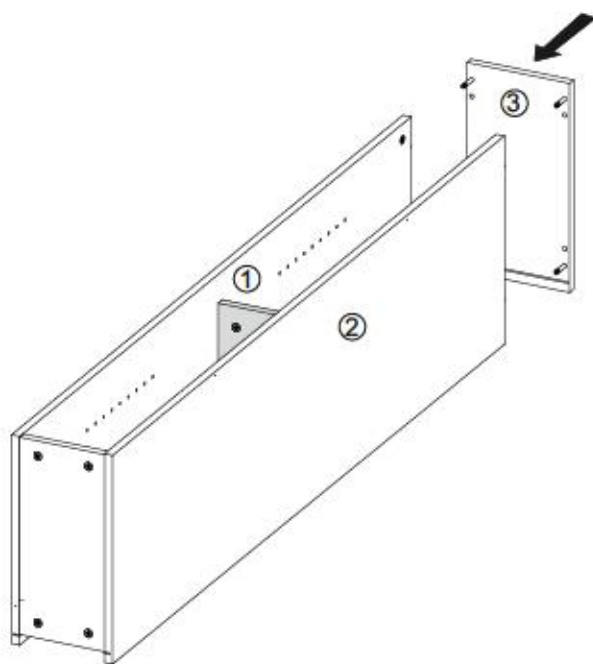

VII

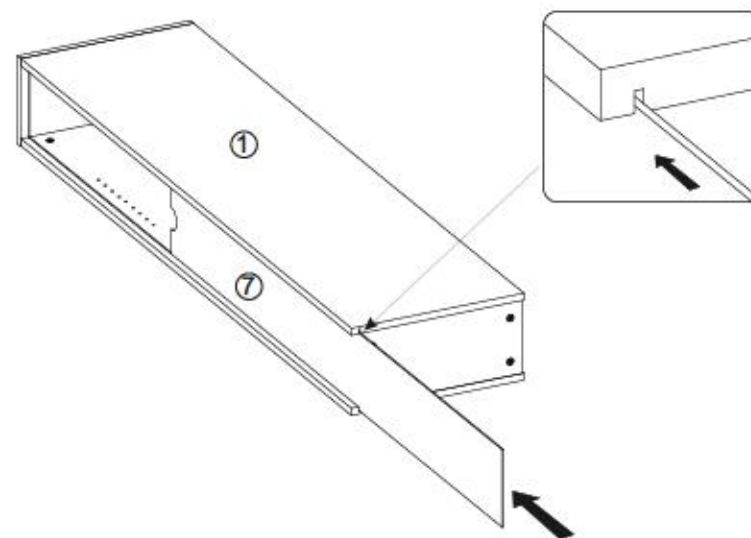

VIII

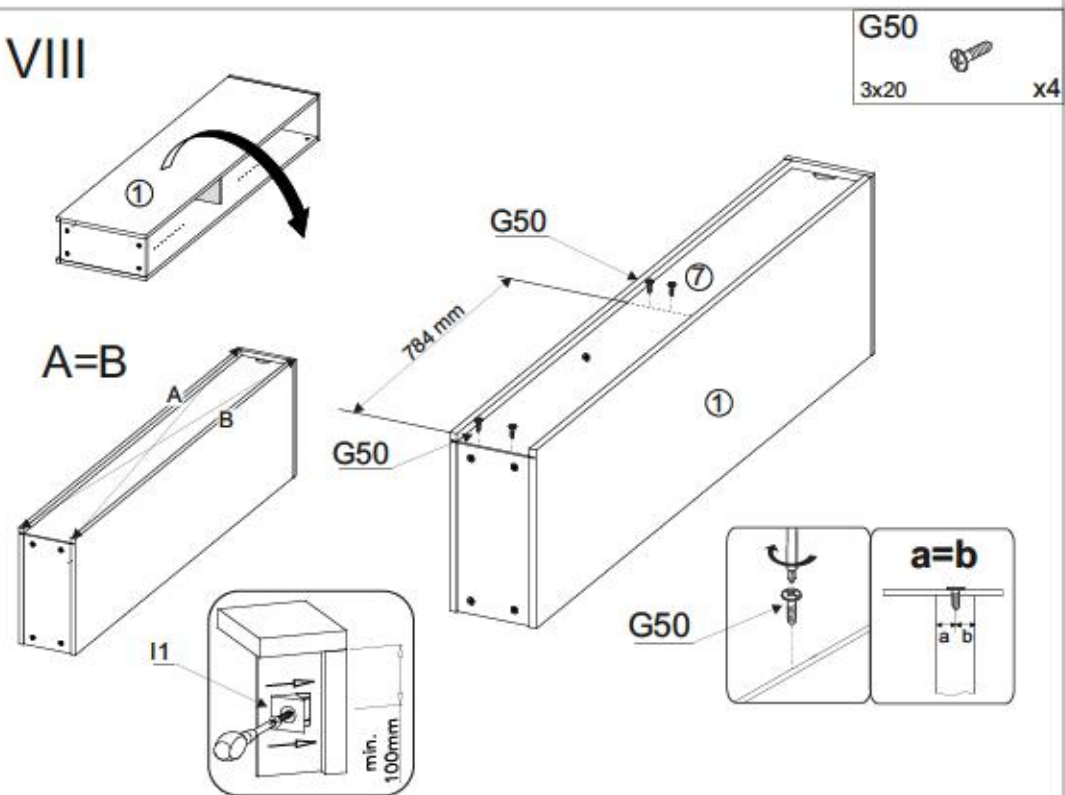



IX

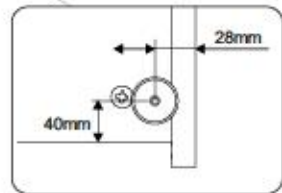
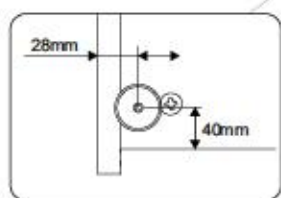
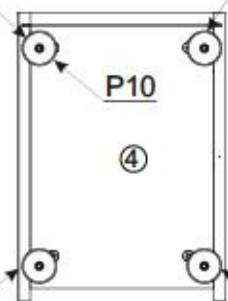
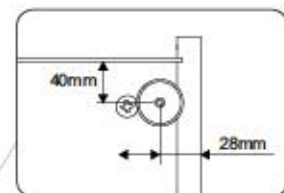
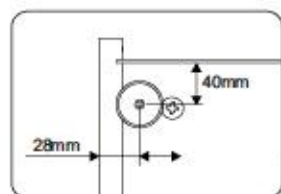
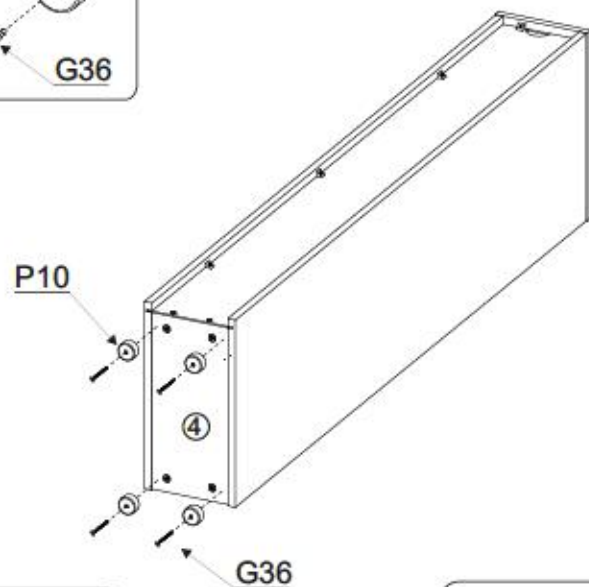
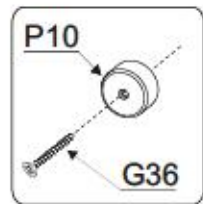



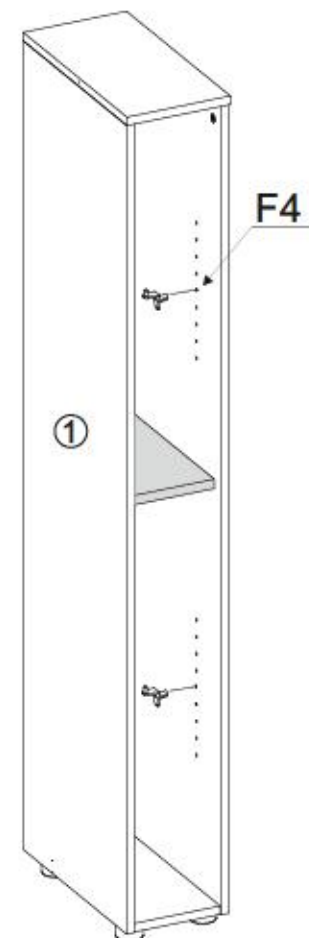
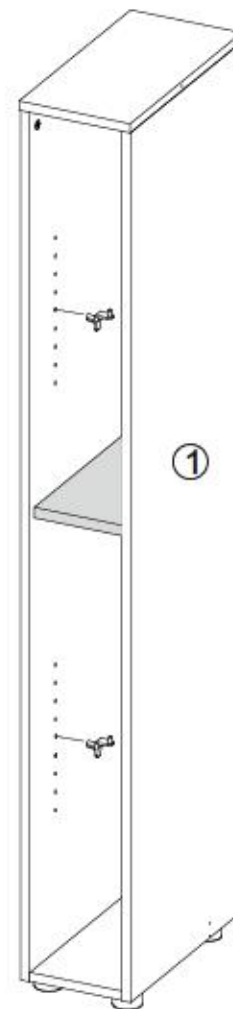
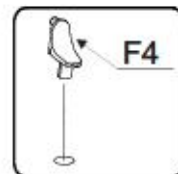
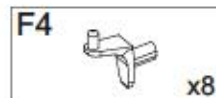



X

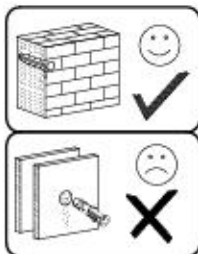



XI



- G34  x1
- 3,5x16  x1
- M11  x1
- I7a  x4
- I7b  x4

M11

M11

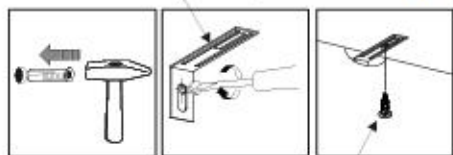
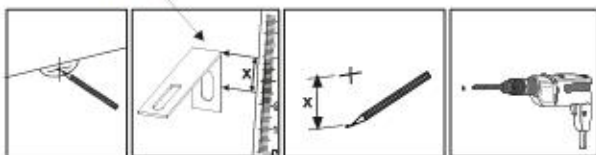

G34

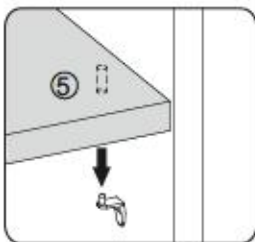
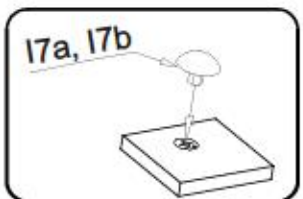
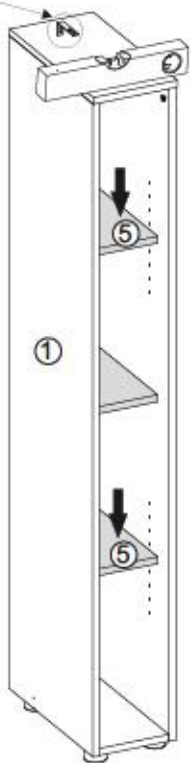

Name • Nom • Nome • Naom • Nazwa • Jméno • Νόζov • Név • Denumire • Isim • Имя	Nr • No • N° • Номер • Č • Sz	Typ • Type • Tip • Típus • Тípo • Tun
CITY / GIRON	--	21

D Unsere Dienstleistung ist beschlagfrei. Sollten Sie diese Servicekarte direkt an die untenstehende Adresse mailen, wir können allerdings nur Beschlagteile auf diesem Wege verschicken. Sollten Sie eine andere Bausituation an Ihrem Möbelstück haben, so wenden Sie sich bitte direkt an Ihr Möbelhaus.

GB Our direct order service for fitting. If a fitting part is missing, you can e-mail this service card directly to the address below. However, we can only send fitting parts in this way. If you have any other issues for completion, concerning your item of furniture, please contact your furniture store directly.

CZ Někdy přikládáme pro konkrétní typy nábytku tuto servisní kartu odešlání emailem přímo na níže uvedenou adresu. Touto cestou však můžeme poslat až jen díly konkrétně. Pokud byste měli nějaký jiný problém, obraťte se přímo na svého prodejce nábytku.

F Bien étudier la notice de montage. Si vous remarque une erreur, veuillez envoyer directement la présente carte service. Toutefois, nous ne pouvons que vous adresser les pièces de rechange. Pour tout autre type de réclamation concernant votre meuble, veuillez contacter directement votre magasin d'ameublement.

I Il nostro servizio è diretto, per i ordini delle braccette. Qualora vi dovesse mancare un pezzo di braccette, allora vi preghiamo di inviare questa carta di servizio immediatamente all'indirizzo sottostante. Possiamo inviare i pezzi di braccette solamente per mezzo di questo procedimento. Qualora dovete avere qualche altro problema in merito al mobile, allora vi preghiamo di rivolgervi direttamente al Vostro Negozio di mobili.

BG Ние имаме директен услуга за обвивки. Ако липоват част от комплектта, потърсете местния магазин наград и не изпращайте на e-mail адреса, защото по-голям. Тя може да бъде получена за доставката на мебелите. Моля, свържете се с обвивката директно с магазина на мебелите.

NL Onze dienstverlening voor losse onderdelen. Wanneer er een onderdeel ontbreekt, kunt u deze servicekaart direct aan onze afdeling e-mailen. Wij kunnen langere dienstverlening niet bieden. Indien u nog andere problemen heeft met uw meubel, verzocht wij u contact op te nemen met uw meubeldealer.

PL Nasz bezpośredni serwis dotyczy części montażowych. Jeżeli brakuje części koniecznych do montażu, prosimy o przesłanie nam niniejszej karty serwisowej na niżej podany adres e-mailowy. W ten sposób możemy przesłać. Pełniejszą listę brakujących części. W przypadku innych składek dotyczących mebla, prosimy o kontakt z naszym meblowcem, w którym został dokonany zakup.

HR Servis za okovne. U slučaju da nedostaje neki od dijelova molimo vas da na dole navedenu mail adresu pošaljete ovaj servisni listić. Na ovaj način mogu se dostaviti samo okovi. U slučaju da imate dodatne prigovore vezane uz lošom namještaju molimo vas da se obično obratite trgovini namještaj gdje je isti kupljen.

HU Direktrendelésünk varakészítésre. Ha hiányzik egy vastag, ezt a kártyát elektronikus úton küldhet az alábbi e-mail címre. Azonban csak az alábbiakhoz tudunk így küldeni. Amennyiben másféle problémák állnak fenn bútorához képest, forduljon közvetlenül a bútoráruházhoz.

SK Náš priamy servis pre čalúň kresla. Ak by Vám chýbala nejaká časť kresla, môžeme poslať tieto kreslárske diely priamo emailem na nižšie uvedenú adresu. Cieľom kresla Vám poslať iba tieto kreslárske diely. Ak by ste mali iné námietky ohľadom vášho nábytku, obráťte sa priamo na Vašu predajňu nábytku.

SLO Njela direktno uslužbovanje stolica za okovje. Če vam manjka kakšno okovje, lahko to sami ano lahko pošljete po e-pošti direktno na spodnji naslov. Po sej postavi vam lahko pošljemo samo okovje. Če imate kakršnakoli kakšen drug del pohištva, se obrnite neposredno na vašo trgovino pohištva.

RO Servisul nostru direct pentru fotosele. În cazul în care vă lipsește o piesă de mobilier (pieșă) și îl trimiteți direct o astfel de card de serviu la adresa de mai jos. Noi nu putem expedia piesa de mobilier decât pe această cale. Dacă aveți o altă reclamație referitoare la piesa de mobilier, atunci vă rugăm să vă adresați direct la magazinul dvs. de mobilier.









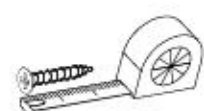

RUS Наш прямой сервис для поставки фурнитуры. Если отсутствует часть Вашего изделия (это может быть элемент фурнитуры), Вы можете отправить сервисную карту по адресу непосредственно на нижеприведенный адрес электронной почты. Однако, таким образом мы можем послать лишь фурнитуру. Если же у Вас возникли иные проблемы относительно прочей мебели, пожалуйста, обращайтесь непосредственно в организацию, осуществляющую продажу.

S Nr. directivă pentru brăcelășe. Or du săltor an brăcelășe len du săltice de la serviciul direct. Dacă lipsește o parte din setul de brăcelășe, trimiteți această card de serviu la adresa de mai jos. Noi nu putem expedia piesa de mobilier decât pe această cale. Dacă aveți o altă reclamație referitoare la piesa de mobilier, atunci vă rugăm să vă adresați direct la magazinul dvs. de mobilier.

ES Nuestro servicio directo para accesorios. Si le falta algún accesorio, puede enviar esta tarjeta de servicio directamente a la siguiente dirección. No obstante, por este método solo podemos enviar accesorios. Si tiene alguna otra objeción sobre su mueble, consulte directamente con su mueblería.

TR Doğrudan işbirlikçi hizmetleri. Eğer donanma parçaları eksikse, lütfen aşağıdaki adresi kullanarak doğrudan mail ile bildirin. Sadece bu yönde donanma parçalarını gönderebiliriz. Mobilyanızda başka şikayetleriniz varsa lütfen doğrudan mobilya satıcınıza danışın.



B1  x...	I7a  x...	I7b  x...
ø8x35		
K1  x...	K10  x...	G36  x...
G34  x...	M11  x...	G50  x...
3,5x16		3x20
P10  x...	F4  x...	



+49 5233 95 290 10

service@mv-steinhelm.de

Name • Nom • Nome • Naom • Nazwa • Jméno • Νόμος • Νέμ • Denumire • Isim • Название	Nr • No • N° • Номер • Č • Sz	Typ • Type • Tip • Трpus • Тipo • Tun
CITY / GIRON	--	21

D Utolsó Díszítésre és Beszélgetésre
Sólyos Irenén és Díszítéssel helyre, kérem, ha ezek a szolgálatok
előtt az a vonatkozó címre kell menni. We können sie erst nach
nur Beschäftigte auf diesem Wege verschicken. Sollten Sie eine
andere Dienstleistung an Ihren Möbelstück haben, so wenden sie
sich bitte direkt an Ihr Möbelhaus.

GB Our direct order service for fitting
If a fitting part is missing, you can e-mail this service card directly
to the address below. However, we can only send fitting parts in
this way if you have any other claims for complaint concerning
your item of furniture, please contact your furniture store directly.

CZ Násle přímá služba pro kování
Chybí-li vám nějaká díl z kování, můžete tuto službu využít odešlat
e-mailem přímo na níže uvedenou adresu. Touto cestou však
můžete rovněž jen díly kování. Pokud byste měli nějaký jiný problém
s výrobkem, obraťte se přímo na svého prodejce nábytku.

F Si un article de la notice de montage
Il vous manque une pièce, veuillez envoyer directement la présente
carte service à l'adresse e-mail indiquée ci-dessous. Cependant, ceci
nous permet uniquement d'envoyer des ferrures. Pour tout autre type
de réclamation ou notamment votre meuble, veuillez contacter
directement votre magasin d'ameublement.

I Il nostro servizio di aiuto per il ordine dei forniture
Qualora vi dovesse mancare un pezzo di fissaggio, allora vi
preghiamo di inviarc questa carta di servizio immediatamente
affinché il pezzo vada spedito. Possiamo inviare i pezzi di fissaggio
solamente per mezzo di questo procedimento. Qualora dovete
avere qualche altra reclamazione in merito al mobile, allora vi
preghiamo di rivolgervi direttamente al Vostro Negozio di mobili.

BG Нашата директна услуга за обнова
Ако ви липват части от комплект, помолете доставителя
свързана карта и не изпращайте ни e-mail адреса, защото
по-рано. По този начин можем да доставим само необходимите
елементи от обнова. Ако установите други дефекти по
мебелта, ви съветваме да се обвързате със мебелната
изпълнението, от който сте закупили обекта.

NL Onze directservice voor losse onderdelen
Wanneer er een onderdeel ontbreekt, kunt u deze servicekaart
direct aan onze dienst e-mailadres sturen. Wij kunnen langzame
weg echter alleen losse onderdelen versturen. Mocht u een ander
probleem aan uw meubel hebben, verzoeken wij u contact op te
nemen met uw meubel dealer.

PL Nasz bezpośredni serwis części montażowych
Jeżeli brakuje części konstrukcyjnych do montażu, prosimy o przesłanie
nam niniejszej karty w celu otrzymania na nią przesyłu adres e-mailowy.
W ten sposób możemy przesyłać Państwu tylko brakujące części.
W przypadku innych reklamacji dotyczących mebla, prosimy zgłaszać
je do naszego meblowego, w którym został dokonany zakup.

HR Servis za otkov
U slučaju da nedostaje neki od dijelova molimo vas da na dole
navedenu mail adresu pošaljete naš službeni obrazac. Na ovaj način
može se dostaviti samo otkov. U slučaju da imate dodatne prigovore
vezane uz komad namještaja molimo vas da se obratite izravno
ingovini namještaja gdje je isti kupljen.

HU Direktnál pórtájk szolgáltatásunk
Ha hiányzik egy vasalat, ezt a kártyát kitöltve elküldheti az
alább látható címre. Azonban csak a vasalatok tudunk így
küldeni. Amennyiben másfajta reklamációt áll lenn kiegészítést
kér, forduljon közvetlenül a bolti munkatársakhoz.

SK Náš priamy servis pre štít kování
Ak by vám chýbala niekajá časť kování, môžete poslať
túto službu kartu priamo e-mailom na nižšie uvedenú
adresu. Cieľom kování a vieme poslať iba tieto príslušenstvá.
Ak by ste mali inú sťažnosť ohľadom Vášho nábytku,
obráťte sa priamo na Vašu predajňu nábytku.

SLO Naše direktna usluga za otkov
V caso in care va lipnija o pleša de furnitur, va rugam sa adresati
e-mail adresi na adresi na spodnji naslov. Po toj poti vam lahko
poslijemo samo otkove. Ce delite nekatere dodatne druge
pritozbe, se obrnite neposredno na vaslo trgovino pohitilo.

RO Serviciul nostru direct pentru kování
În cazul în care vă lipsește o piesă de furnitură, vă rugăm să trimiteți
direct această card de serviciu prin e-mail la adresa de e-mail din
pagina. Serviciul nostru poate să vă trimite doar
piese de kování și nu putem să vă trimitem alte
reclamații sau informații în legătură cu mobilierul.
Dacă aveți o altă reclamație referitoare la piesa de mobilier,
vă rugăm să vă adresați direct la magazinul dvs. de mobilier.

RUS Наш прямой сервис для поставки фурнитуры
Если отсутствует часть или комплект фурнитуры, вы можете отправить сервисную карту по адресу
непосредственно на неограниченный адрес электронной
почты. Однако, такие образом мы можем переслать лишь
фурнитуру. Если же у вас имеются другие претензии относительно
конкретной мебели, пожалуйста, обращайтесь
непосредственно в магазин, осуществляющий продажу.

S Měr direktní služba pro štít kování
Om du mangar en beslagdel kan du skicka detta servicekort till oss
Härmed kan vi skicka delar till dig. Vi kan dock inte skicka andra
typer av beslagdelar eller andra typer av reklamationer.
Om du har andra klagomål rörande ditt möbelsåg, direkt
kontakt med din möbelsåg.

ES Nuestro servicio directo para accesorios
Si le falta algún accesorio, puede enviar esta tarjeta de servicio directamente
a la siguiente dirección. No obstante, por este método solo podemos
enviar accesorios. Si tiene el gura otra objeción sobre su mueble, consulte
directamente con su mueblería.

TR Doğrudan hizmet için aksesuarlar
Eğer bir aksesuar eksikse bu servisi birinci doğrudan adresimize bu adresle
doğrudan mail ile gönderebilirsiniz. Ancak bu yöntemle sadece aksesuarlar
gönderebiliriz. Mobilyanızla ilgili diğer sorularınız için doğrudan mobilya satıcınıza
başvurunuz.

nr	L [mm]	R [mm]	T [mm]	Menge	Coll
1	1532	400	16	1	1/1
2	1532	400	16	1	1/1
3	200	401	16	1	1/1
4	166	378	16	1	1/1
5	166	325	16	2	1/1
6	166	325	16	1	1/1
7	1534	176	3	1	1/1

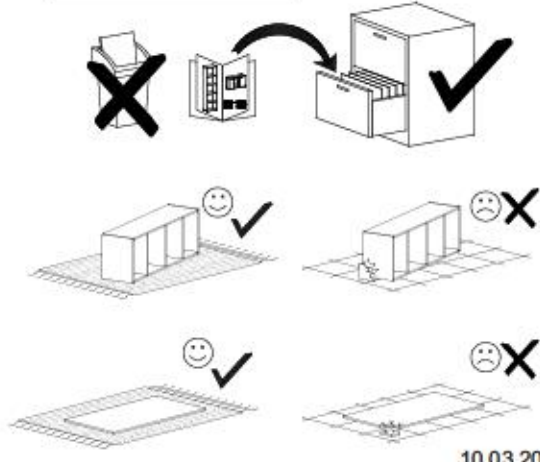
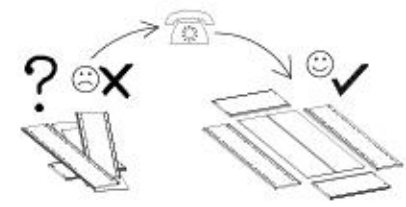
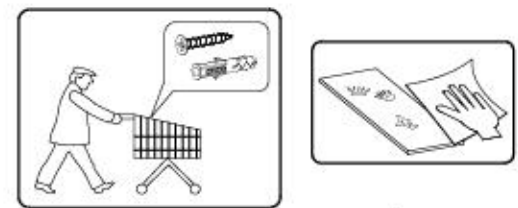
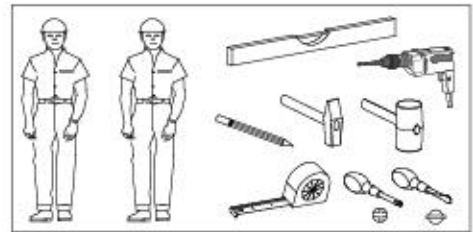
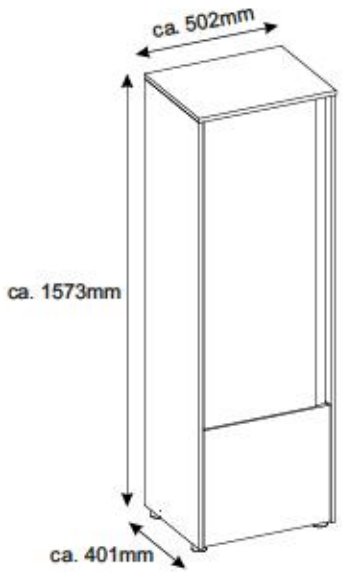
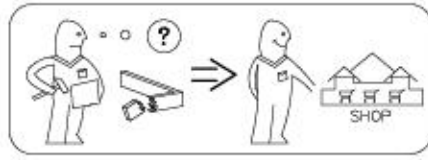
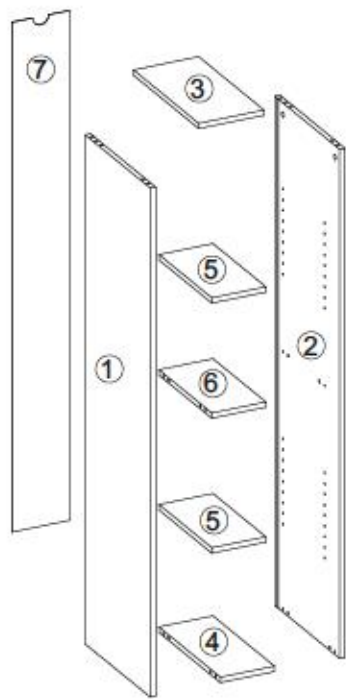

- Ⓛ Montageanleitung
- Ⓝ Handleiding voor de montage
- Ⓡ Montaj talimat
- ⓕ Notice de montage
- Ⓒ Montážní návod
- ⓗ Szerelési útmutató
- ⓖ Assembly Instructions
- Ⓟ Instrukcja montażu
- Ⓡ Инструкция по монтажу
- Ⓡ Istruzioni di montaggio
- Ⓢ Návod na montáž
- Ⓡ Instrucțiuni de montaj
- ⓔ Instrucciones de montaje
- Ⓡ Montaj Talimat



n°	L[mm]	B[mm]	T[mm]	Usage	Coll
1	1532	400	16	1	1/1
2	1532	400	16	1	1/1
3	502	401	16	1	1/1
4	468	362	16	2	1/1
5	468	322	16	2	1/1
6	1116	77	38	1	1/1
7	419	463	16	1	1/1
8	1105	410	16	1	1/1
9	1534	478	3	1	1/1

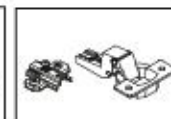
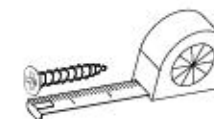
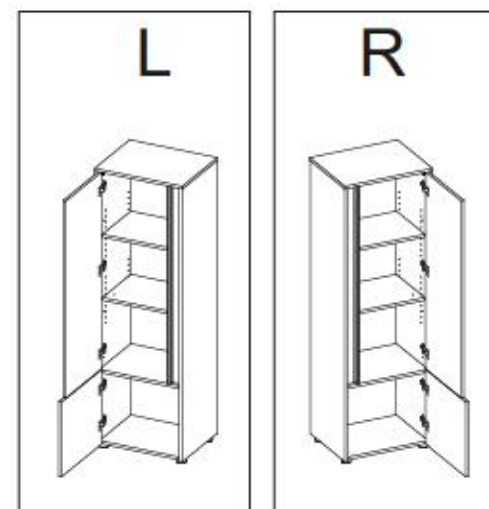
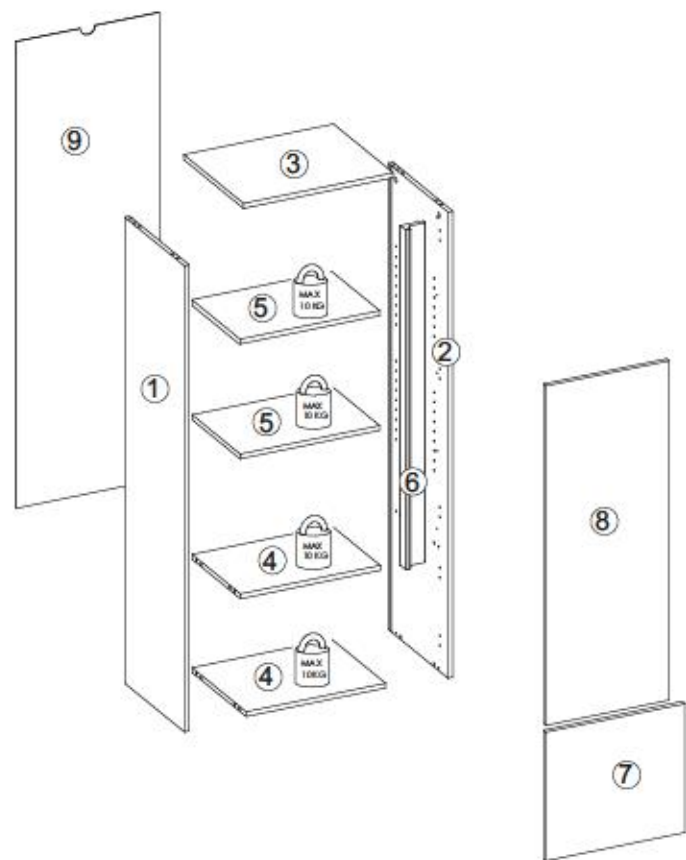

B1 ø8x35 x12	I7 x8	K1 x12	K10 x12	D4 x5
C6 x5	G36 4x30 x4	G34 3,5x16 x11	G49 4x16 x10	F13 x5
I1 x7	M11 x1	G50 3x20 x8	P10 x4	F2 x8



I

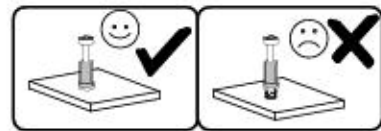
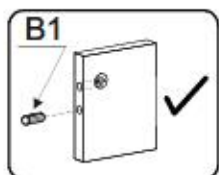
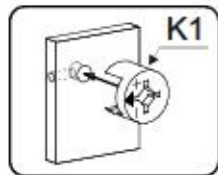
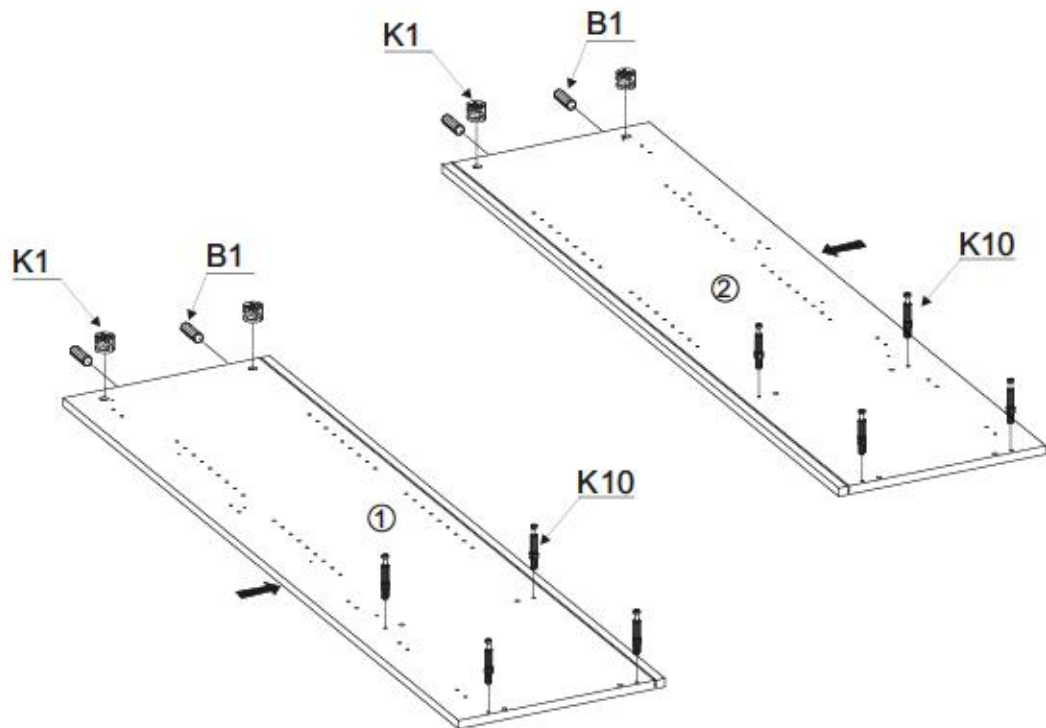
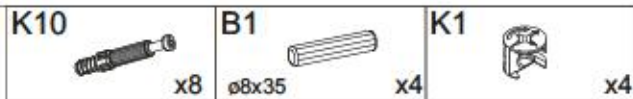

II

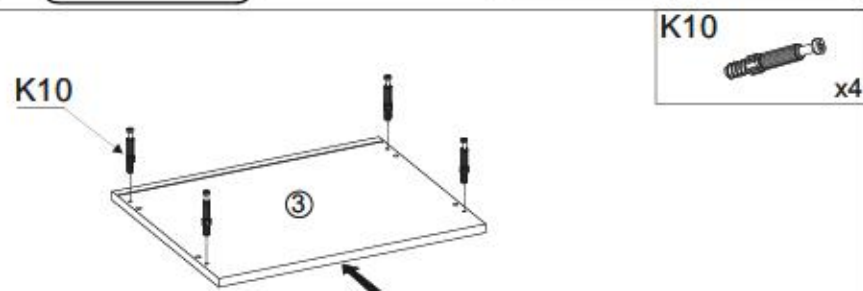

III

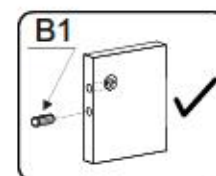
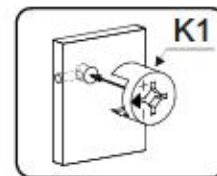
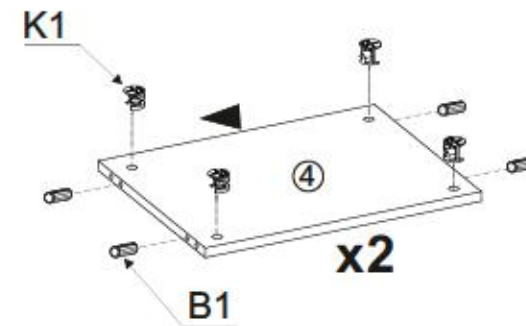
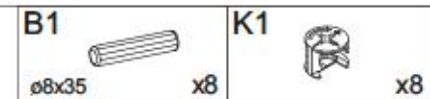

IV

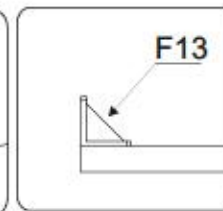
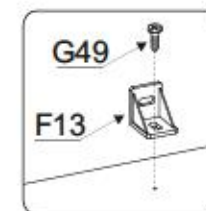
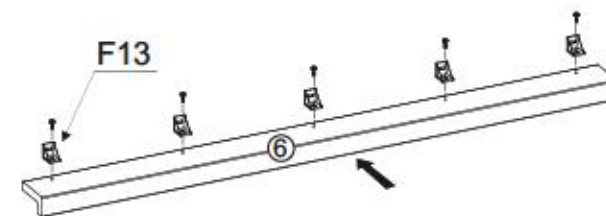
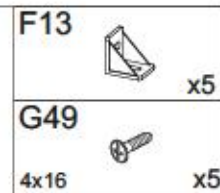



V

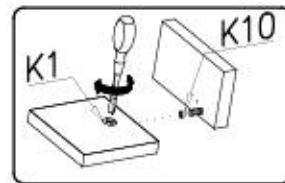
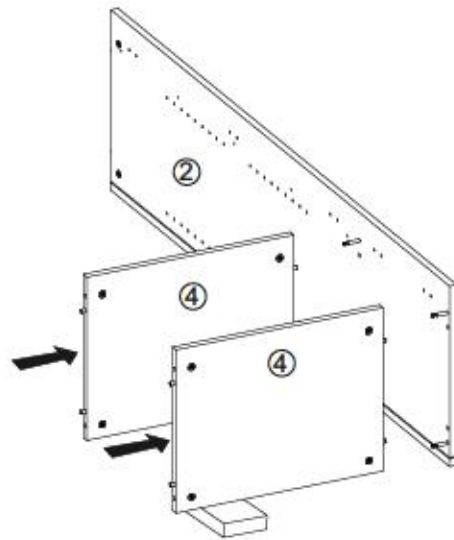

VII

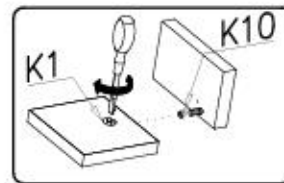
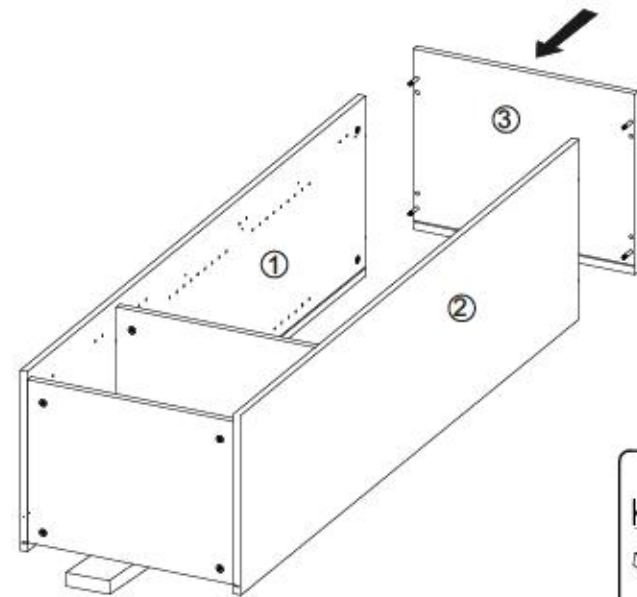

VI

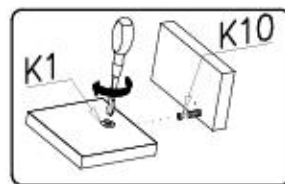
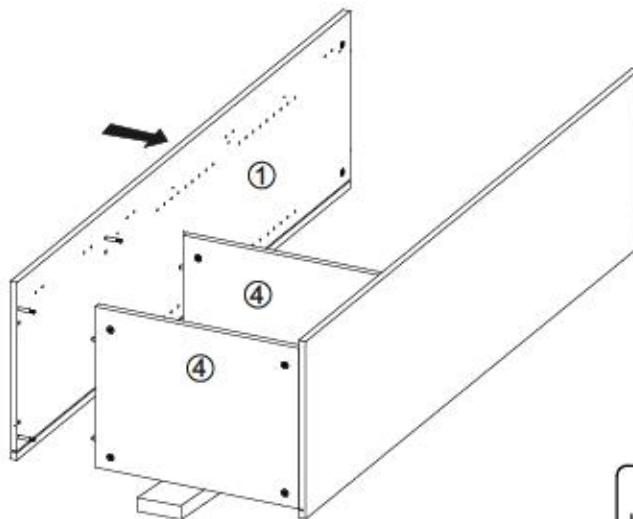

VIII

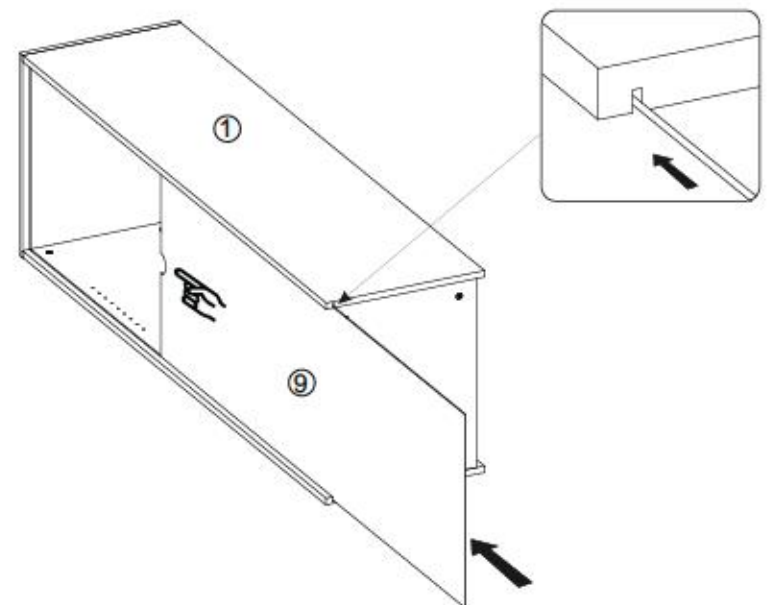

8/17

CITY / GIRON 28



IX

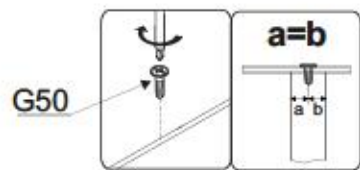
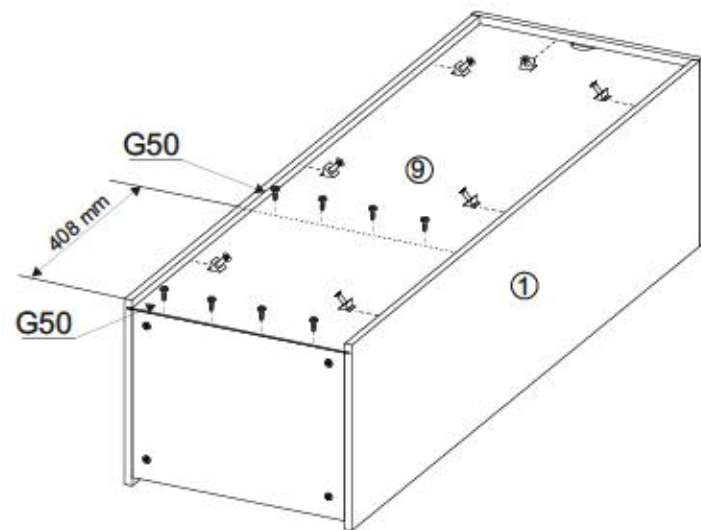
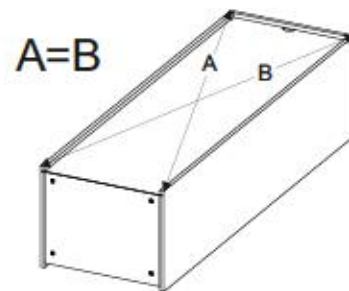
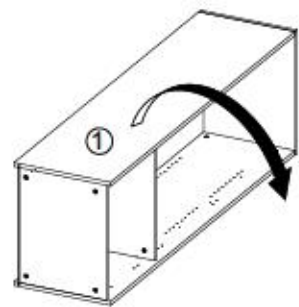

G50
3x20 x8

I1



x7



9/17

CITY / GIRON 28



X

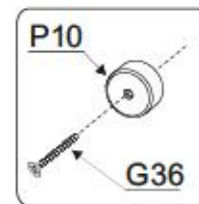

P10 x4

G36

4x30 x4

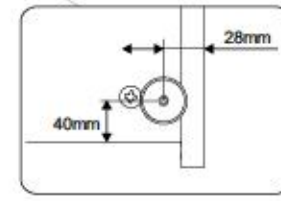
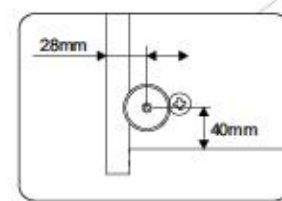
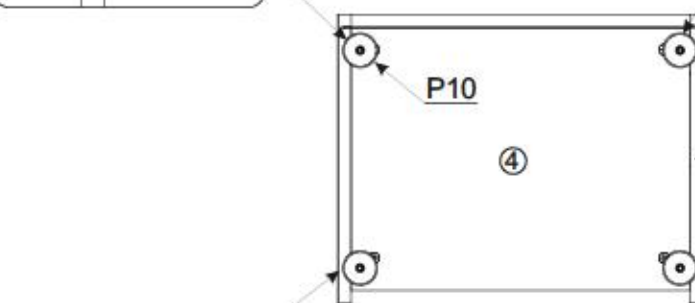
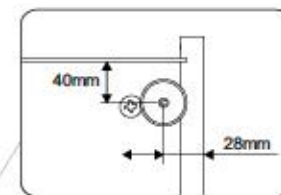
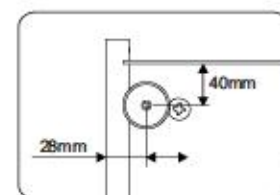
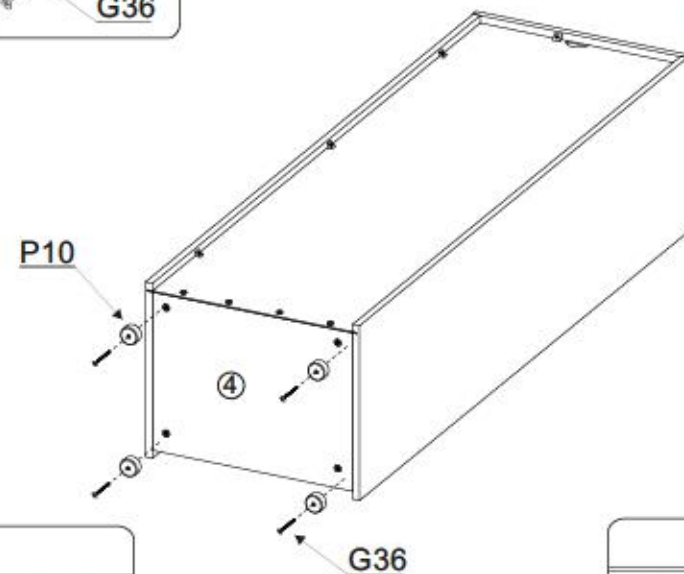

10/17

CITY / GIRON 28



XI

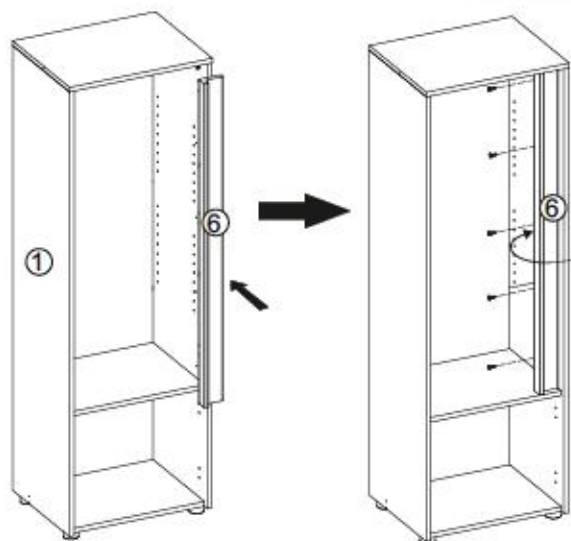
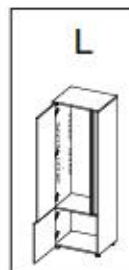

I7



x8

G49



x5

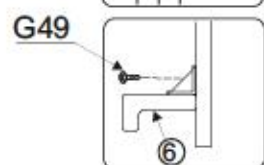
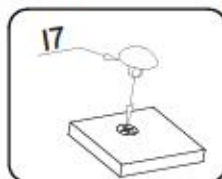

11/17

CITY / GIRON 28



XII

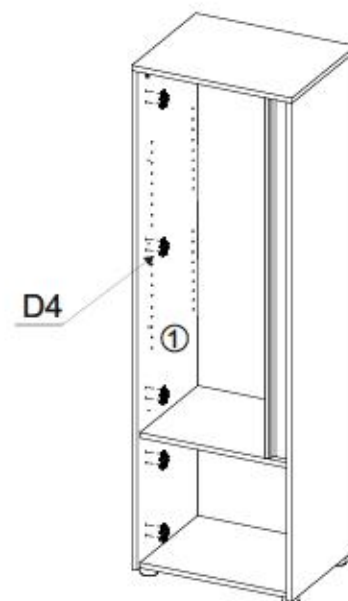
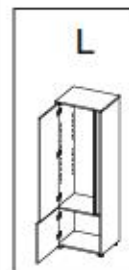

D4



x5

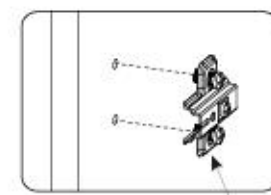

D4

R

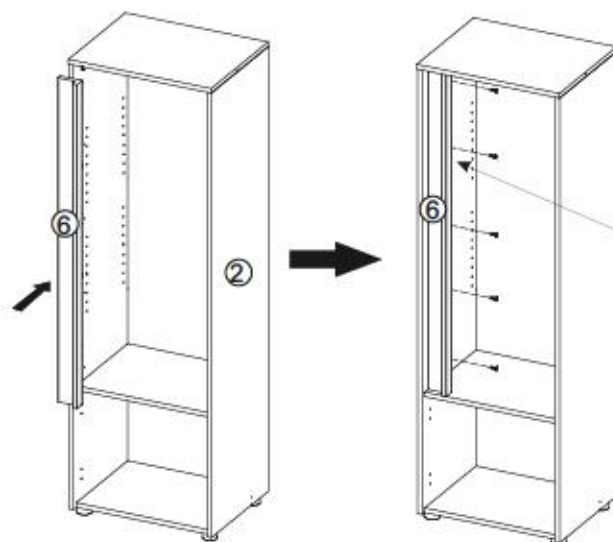
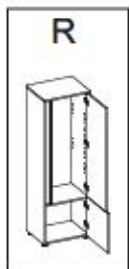

G49

4x16



x5

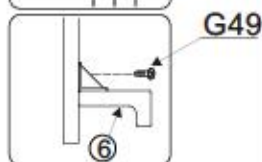
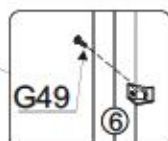

R

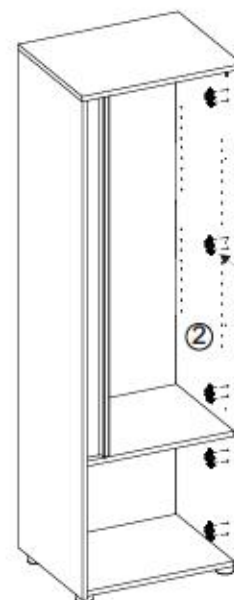
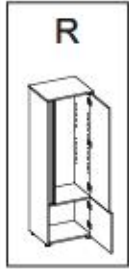

D4



x5

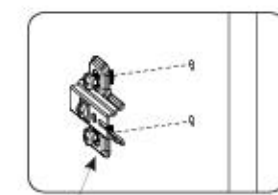

D4

12/17

CITY / GIRON 28



XIII

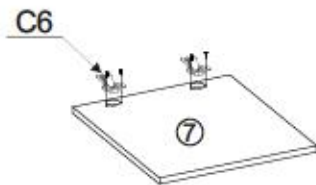
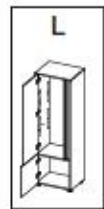
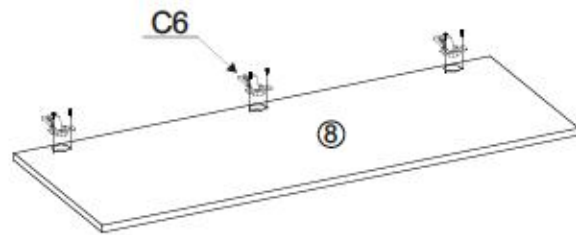

C6



x5

G34



3,5x16

x10

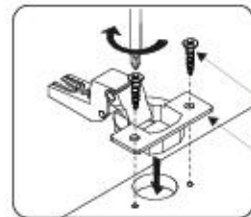

G34

C6

13/17

CITY / GIRON 28



XV

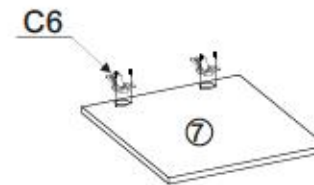
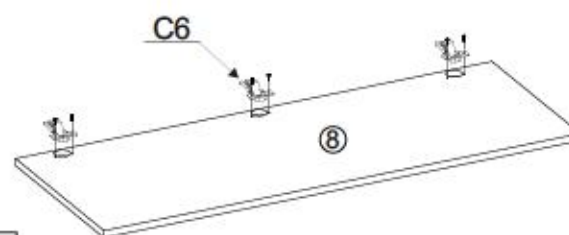

C6



x5

G34



3,5x16

x10

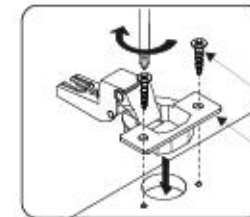

G34

C6

XIV

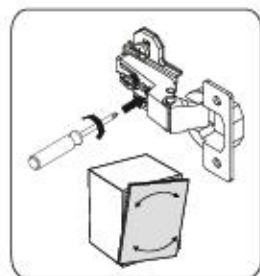
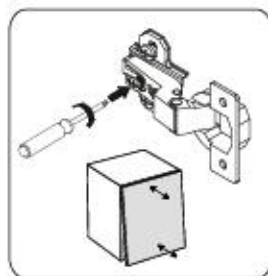
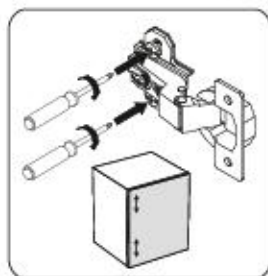
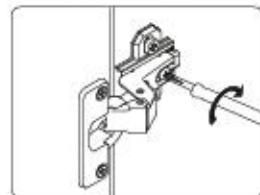
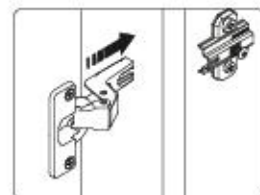
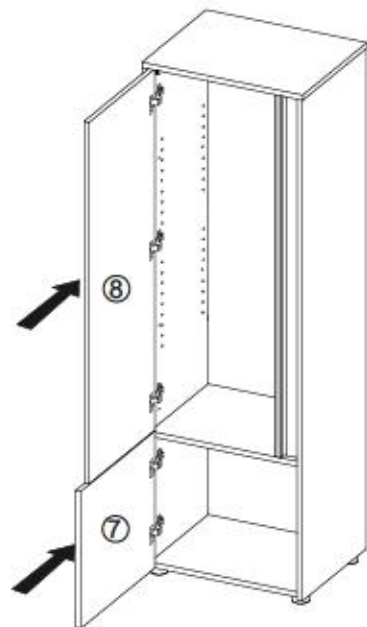
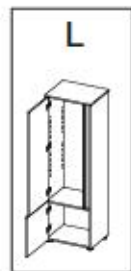

XVI

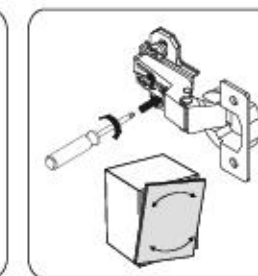
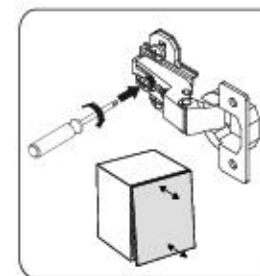
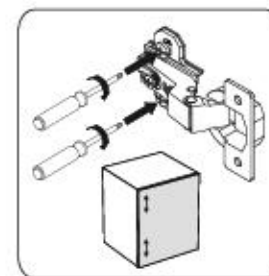
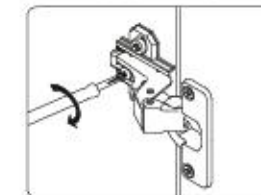
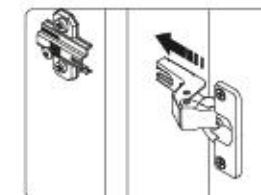
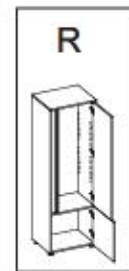



XVII

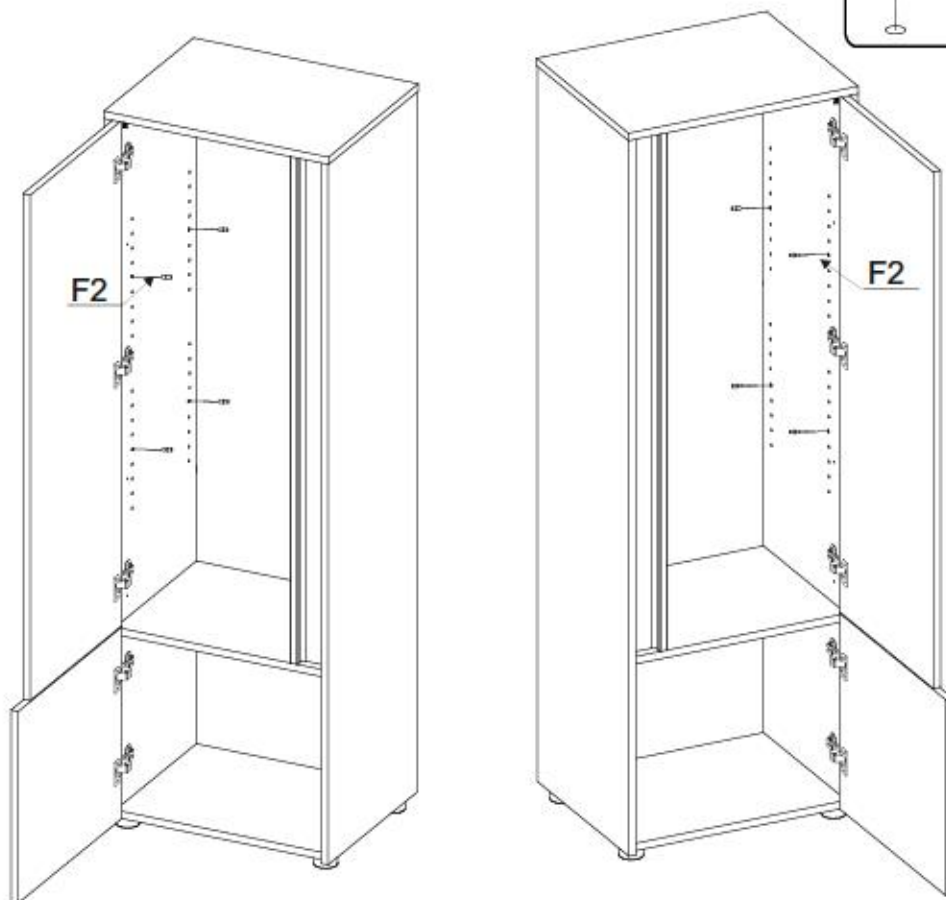
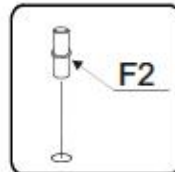

XVIII

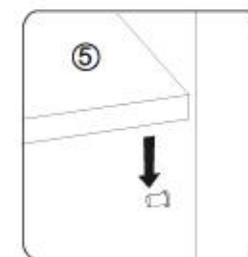
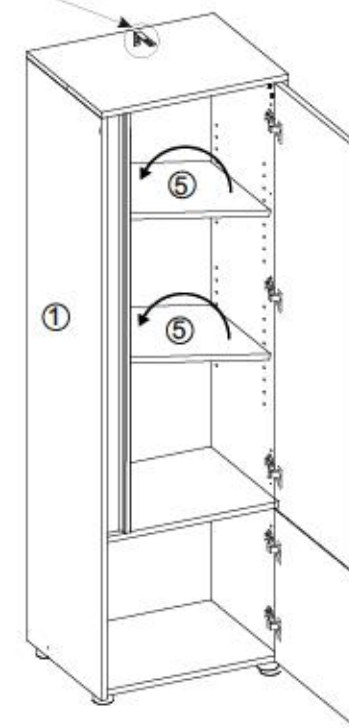
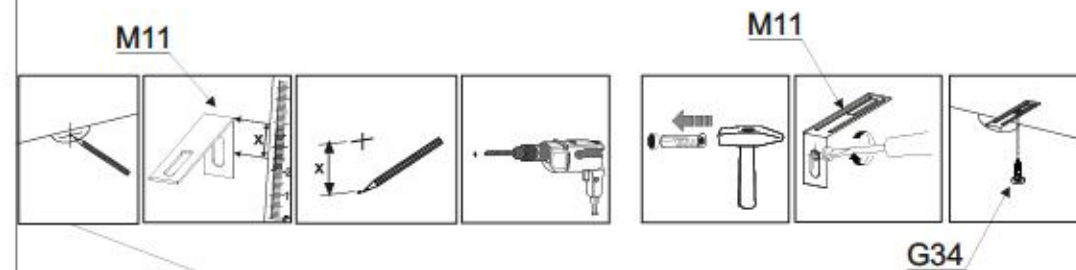
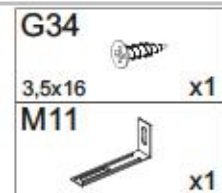
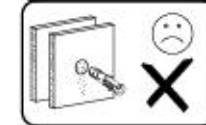
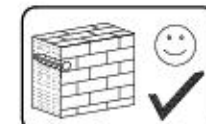

16/17 Service • Assistenza • Dienstverlening • Serwis • Servis • Szerviz • Сервисная служба

Name • Nom • Nome • Naom • Nazwa • Имя
• Názov • Név • Denumire • Isim • Имя
CITY / GIRON
-- 28

D Unsere Dienstleistung ist beschlaglos.
Sollte Ihnen ein Beschlagfallen haben, können Sie diese Servicekarte direkt an die untenstehende Adresse mailen. Wir können ansonsten nur Beschlagfälle auf diesem Wege verschicken. Sollten Sie eine andere Beseitigung an Ihrem Möbelstück haben, so wenden Sie sich bitte direkt an Ihr Möbelhaus.

GB Our direct order service is for filling.
If a filling part is missing, you can e-mail this service card directly to the address below. However, we can only send filling parts in this way if you have any other cause for complaint concerning your item of furniture, please contact your furniture store directly.

CZ Naše příslužba slouží pro kování.
Chybí-li vám nějaký díl z kování, můžete tuto službu rovněž odeslat e-mailem přímo na níže uvedenou adresu. Touto cestou však můžeme doručit jen díly kování. Pokud byste měli jinou příčinu stížnosti, obraťte se přímo na svého prodejce nábytku.

F Bien étudier la notice de montage.
Si vous remarque une erreur, veuillez envoyer directement la présente carte service à l'adresse e-mail indiquée ci-dessous. Cependant, ce nous permet uniquement d'envoyer des fournitures. Pour tout autre type de réclamation concernant votre meuble, veuillez contacter directement votre magasin d'ameublement.

I Il nostro servizio di aiuto per il ordine dei fornimenti.
Qualora Vi dovesse mancare un pezzo di fissaggio, allora Vi preghiamo di inviare questa carta di servizio immediatamente all'indirizzo sottostante. Possiamo inviare i pezzi di fissaggio solamente per mezzo di questo procedimento. Qualora dovete avere qualche altra richiesta in merito al mobile, allora Vi preghiamo di rivolgerVi direttamente al Vostro Negozio di mobili.

BG Нашата директна услуга за облек
Ако липневат части от комплектта, потърсете настоящата сервисна карта и я изпратете на e-mail адреса, посочен по-долу. По този начин можем да доставим само необходимите елементи от облека. Ако установите други дефекти по мебелта, би съветваме да се обвържете със мебелното изпълнение, от който сте закупили стоката.

NL Onze directievoor voor losse onderdelen.
Wanneer er een onderdeel ontbreekt, kunt u deze servicekaart direct aan onderstaand e-mailadres sturen. Wij kunnen langzame des weg echter alleen best geplaatste vastmaken. Mocht u een ander probleem aan uw meubel hebben, verzoeken wij u contact op te nemen met uw meubeldealer.

PL Nasz bezpośredni serwis części montażowych.
Jeżeli brakuje części koniecznych do montażu, prosimy o przesłanie nam niniejszej karty serwisowej na niżej podany adres e-mailowy. W ten sposób możemy przesłać: Pełniaku tylko brakujących części. W przypadku innych reklamacji dotyczących mebla, prosimy zgłaszać się do salonu meblowego, w którym został dokonany zakup.

HR Servis za otkove.
U slučaju da nedostaje neki od dijelova meblima vas da na dalje poveravamo mail adresom koji je na dnu ove službenice. Na ovaj način mogu se dostaviti samo otkovi. U slučaju da imate dodatne prigovore vezane uz komad namještaja molimo vas da se obratite izravno trgovini namještaja gdje je isti kupljen.

HU Direktrendelésünk vasalattal szemben.
Ha hiányzik egy vasalat, ezt a kártyát elektronikus úton küldheti az alább található címre. Azonban csak vasalattal tudunk így küldeni. Amennyiben másféle reklamációt állít fel, kérésedre megbeszélhetünk a boltunkkal.

SK Náš priamy servis pri čístej kováni.
Ak by Vám chýbala nejaká časť kováni, môžete poslať túto službu rovnako priamo e-mailom na nižšie uvedenú adresu. Cieľou kováni vieme poslať iba týmto spôsobom. Ak by ste mali inú reklamáciu ohľadom vášho nábytku, obráťte sa priamo na Vašu predajňu nábytku.

SLO Naše direktno uslužbovanje služi za otkove.
U slučaju da nedostaje neki od dijelova meblima vas da na dalje poveravamo mail adresom koji je na dnu ove službenice. Na ovaj način mogu se dostaviti samo otkovi. U slučaju da imate dodatne prigovore vezane uz komad namještaja molimo vas da se obratite izravno trgovini namještaja gdje je isti kupljen.

RO Serviciul nostru direct pentru furnitură.
Căci în cazul în care vă lipsește o piesă de la seturile de mobilier, puteți trimite această card de serviciu prin e-mail la adresa de mai jos. Noi nu putem expedia piesa de furnitură decât pe această cale. Dacă aveți o altă reclamație referitoare la piesa de mobilier, atunci vă rugăm să vă adresați direct la magazinul dvs. de mobilier.

RUS Наш прямой сервис при поставке фурнитуры.
Если замечается, что Вам не хватает того или иного элемента фурнитуры, Вы можете отправить сервисную карту по адресу непосредственно на нижеприведенный адрес электронной почты. Однако, таким образом мы можем переслать лишь фурнитуру. Если же у Вас возникнут иные претензии относительно приобретенной мебели, пожалуйста, обращайтесь непосредственно в магазин, осуществляющий продажу.

S Vår direktna tjena för beställningar.
Om du saknar en beställad del du skulle detta servicekort direkt till e-postadressen som anges nedan. Tillåt oss dock att den enda delen vi kan skicka är beställningar till dig. Om du vill reklamera din möbel av annan anledning än till den kontakta ditt möbelföretag direkt.

ES Nuestro servicio directo para accesorios.
Si le falta algún accesorio, puede enviar esta tarjeta de servicio directamente a la siguiente dirección. No obstante, por este método solo podemos enviar accesorios. Si tiene alguna otra objeción sobre su mueble, consulte directamente con su mueblería.

TR Doğrudan lütfen doğrudan servisleriniz.
Eğer donatılar eksikse bu servis kartını doğrudan aşağıdaki buzanan adrese doğrudan mail ile gönderebilirsiniz. Sadece bu yolu kullanarak gönderebilirsiniz. Mobilyanızda başka şikayetleriniz varsa lütfen doğrudan mobilya satışınıza dönün.



B1 ø8x35 X...	I7 X...	K1 X...
K10 X...	D4 X...	C6 X...
G36 4x30 X...	G34 3,5x16 X...	G49 4x16 X...
F13 X...	I1 X...	M11 X...
G50 3x20 X...	P10 X...	F2 X...

service@mv-steinheim.de

+49 5233 95 290 10

17/17 Service • Assistenza • Dienstverlening • Serwis • Servis • Szerviz • Сервисная служба

Name • Nom • Nome • Naom • Nazwa • Имя
• Názov • Név • Denumire • Isim • Имя
CITY / GIRON
-- 28

D Unsere Dienstleistung ist beschlaglos.
Sollte Ihnen ein Beschlagfallen haben, können Sie diese Servicekarte direkt an die untenstehende Adresse mailen. Wir können ansonsten nur Beschlagfälle auf diesem Wege verschicken. Sollten Sie eine andere Beseitigung an Ihrem Möbelstück haben, so wenden Sie sich bitte direkt an Ihr Möbelhaus.

GB Our direct order service is for filling.
If a filling part is missing, you can e-mail this service card directly to the address below. However, we can only send filling parts in this way if you have any other cause for complaint concerning your item of furniture, please contact your furniture store directly.

CZ Naše příslužba slouží pro kování.
Chybí-li vám nějaký díl z kování, můžete tuto službu rovněž odeslat e-mailem přímo na níže uvedenou adresu. Touto cestou však můžeme doručit jen díly kování. Pokud byste měli jinou příčinu stížnosti, obraťte se přímo na svého prodejce nábytku.

F Bien étudier la notice de montage.
Si vous remarque une erreur, veuillez envoyer directement la présente carte service à l'adresse e-mail indiquée ci-dessous. Cependant, ce nous permet uniquement d'envoyer des fournitures. Pour tout autre type de réclamation concernant votre meuble, veuillez contacter directement votre magasin d'ameublement.

I Il nostro servizio di aiuto per il ordine dei fornimenti.
Qualora Vi dovesse mancare un pezzo di fissaggio, allora Vi preghiamo di inviare questa carta di servizio immediatamente all'indirizzo sottostante. Possiamo inviare i pezzi di fissaggio solamente per mezzo di questo procedimento. Qualora dovete avere qualche altra richiesta in merito al mobile, allora Vi preghiamo di rivolgerVi direttamente al Vostro Negozio di mobili.

BG Нашата директна услуга за облек
Ако липневат части от комплектта, потърсете настоящата сервисна карта и я изпратете на e-mail адреса, посочен по-долу. По този начин можем да доставим само необходимите елементи от облека. Ако установите други дефекти по мебелта, би съветваме да се обвържете със мебелното изпълнение, от който сте закупили стоката.

NL Onze directievoor voor losse onderdelen.
Wanneer er een onderdeel ontbreekt, kunt u deze servicekaart direct aan onderstaand e-mailadres sturen. Wij kunnen langzame des weg echter alleen best geplaatste vastmaken. Mocht u een ander probleem aan uw meubel hebben, verzoeken wij u contact op te nemen met uw meubeldealer.

PL Nasz bezpośredni serwis części montażowych.
Jeżeli brakuje części koniecznych do montażu, prosimy o przesłanie nam niniejszej karty serwisowej na niżej podany adres e-mailowy. W ten sposób możemy przesłać: Pełniaku tylko brakujących części. W przypadku innych reklamacji dotyczących mebla, prosimy zgłaszać się do salonu meblowego, w którym został dokonany zakup.

HR Servis za otkove.
U slučaju da nedostaje neki od dijelova meblima vas da na dalje poveravamo mail adresom koji je na dnu ove službenice. Na ovaj način mogu se dostaviti samo otkovi. U slučaju da imate dodatne prigovore vezane uz komad namještaja molimo vas da se obratite izravno trgovini namještaja gdje je isti kupljen.

HU Direktrendelésünk vasalattal szemben.
Ha hiányzik egy vasalat, ezt a kártyát elektronikus úton küldheti az alább található címre. Azonban csak vasalattal tudunk így küldeni. Amennyiben másféle reklamációt állít fel, kérésedre megbeszélhetünk a boltunkkal.

SK Náš priamy servis pri čístej kováni.
Ak by Vám chýbala nejaká časť kováni, môžete poslať túto službu rovnako priamo e-mailom na nižšie uvedenú adresu. Cieľou kováni vieme poslať iba týmto spôsobom. Ak by ste mali inú reklamáciu ohľadom vášho nábytku, obráťte sa priamo na Vašu predajňu nábytku.

SLO Naše direktno uslužbovanje služi za otkove.
U slučaju da nedostaje neki od dijelova meblima vas da na dalje poveravamo mail adresom koji je na dnu ove službenice. Na ovaj način mogu se dostaviti samo otkovi. U slučaju da imate dodatne prigovore vezane uz komad namještaja molimo vas da se obratite izravno trgovini namještaja gdje je isti kupljen.

RO Serviciul nostru direct pentru furnitură.
Căci în cazul în care vă lipsește o piesă de la seturile de mobilier, puteți trimite această card de serviciu prin e-mail la adresa de mai jos. Noi nu putem expedia piesa de furnitură decât pe această cale. Dacă aveți o altă reclamație referitoare la piesa de mobilier, atunci vă rugăm să vă adresați direct la magazinul dvs. de mobilier.

RUS Наш прямой сервис при поставке фурнитуры.
Если замечается, что Вам не хватает того или иного элемента фурнитуры, Вы можете отправить сервисную карту по адресу непосредственно на нижеприведенный адрес электронной почты. Однако, таким образом мы можем переслать лишь фурнитуру. Если же у Вас возникнут иные претензии относительно приобретенной мебели, пожалуйста, обращайтесь непосредственно в магазин, осуществляющий продажу.

S Vår direktna tjena för beställningar.
Om du saknar en beställad del kan du skicka detta servicekort direkt till e-postadressen som anges nedan. Tillåt oss dock att den enda delen vi kan skicka är beställningar till dig. Om du vill reklamera din möbel av annan anledning än till den kontakta ditt möbelföretag direkt.

ES Nuestro servicio directo para accesorios.
Si le falta algún accesorio, puede enviar esta tarjeta de servicio directamente a la siguiente dirección. No obstante, por este método solo podemos enviar accesorios. Si tiene alguna otra objeción sobre su mueble, consulte directamente con su mueblería.

TR Doğrudan lütfen doğrudan servisleriniz.
Eğer donatılar eksikse bu servis kartını doğrudan aşağıdaki buzanan adrese doğrudan mail ile gönderebilirsiniz. Sadece bu yolu kullanarak gönderebilirsiniz. Mobilyanızda başka şikayetleriniz varsa lütfen doğrudan mobilya satışınıza dönün.

nr	L[mm]	d[mm]	T[mm]	Menge	Call
1	1532	400	16	1	1/1
2	1532	400	16	1	1/1
3	502	401	16	1	1/1
4	468	362	16	2	1/1
5	468	322	16	2	1/1
6	1116	77	38	1	1/1
7	419	463	16	1	1/1
8	1105	410	16	1	1/1
9	1534	478	3	1	1/1

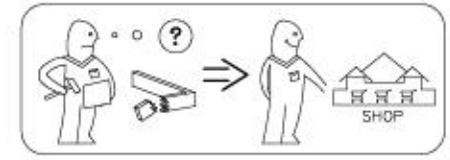
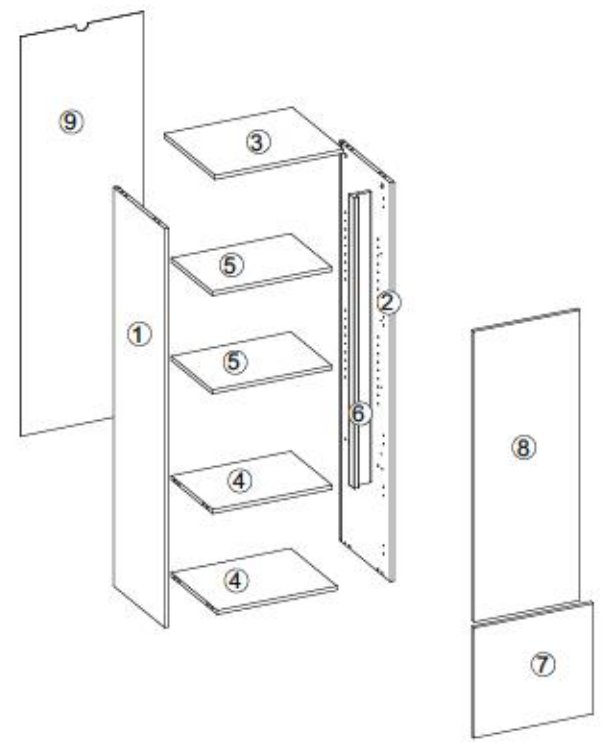



- ⓓ **Montageanleitung**
- ⓃⓁ **Handleiding voor de montage**
- ⓉⓇ **Montaj talimatı**
- ⓕ **Notica de montage**
- ⒸⓏ **Montážní návod**
- ⓗⓤ **Szerelési útmutató**
- ⓖⓔ **Assembly Instructions**
- Ⓟ **Instrukcja montażu**
- Ⓡⓤ **Инструкция по монтажу**
- Ⓡⓐ **Istruzioni di montaggio**
- ⓈⓀ **Návod na montáž**
- Ⓡⓞ **Instrucțiunile de montaj**
- ⓔⓢ **Instrucciones de montaje**
- ⓉⓇ **Montaj Talimatı**

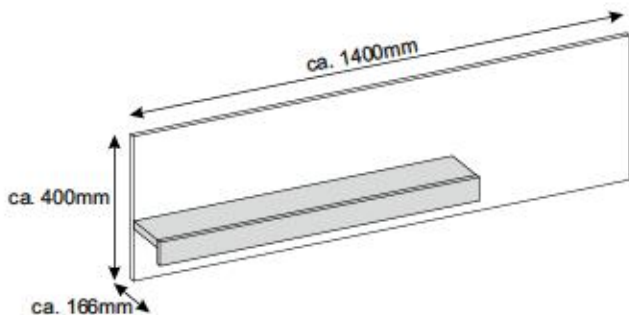

n°	L[mm]	B[mm]	T[mm]	Versione	Coli
1	1400	400	16	1	1/1
2	900	134	16	1	1/1
3	902	65	16	1	1/1

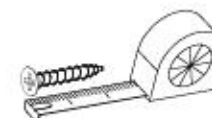
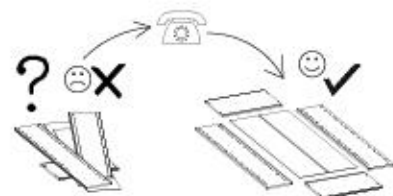
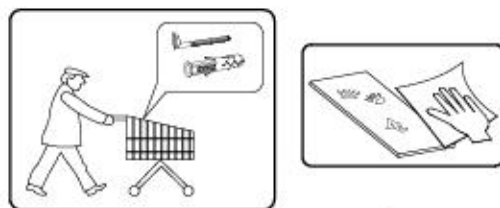
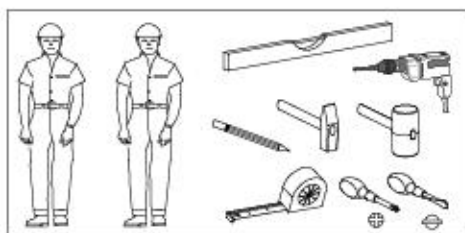
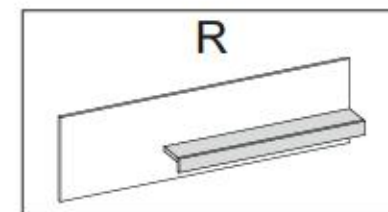
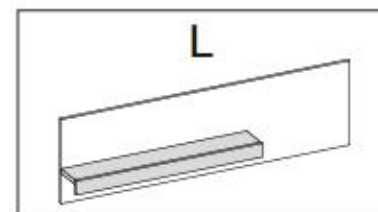
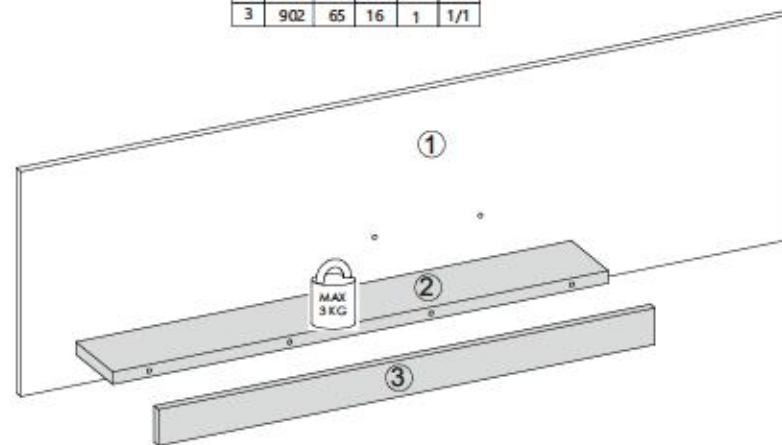

A1 ø7x50 x4	W2 x1	G52 5x11 x6	P10 x3	I7 x4
K1 x4	K10 x4			

3/8

CITY / GIRON 73



I

G52

5x11



x6

P10



x3

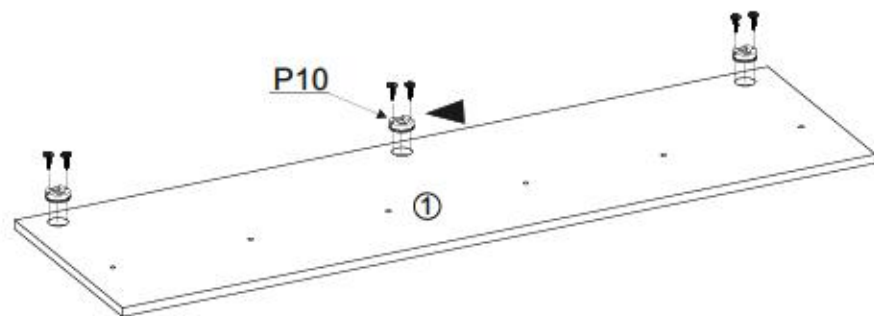

P10

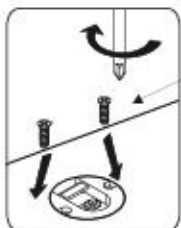
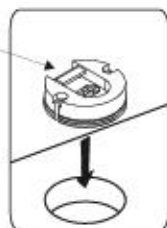

G52



II

K1

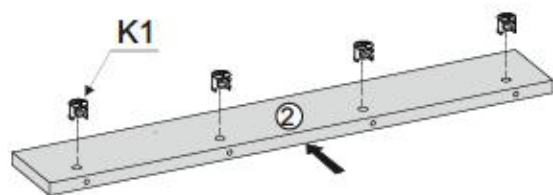

K1

x4



K10

x4



K10

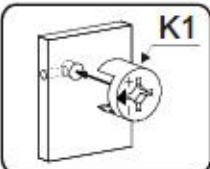
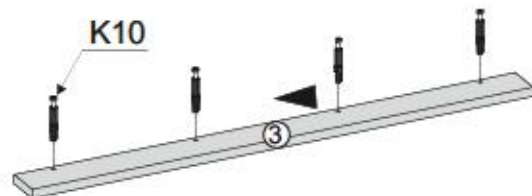

4/8

CITY / GIRON 73



III

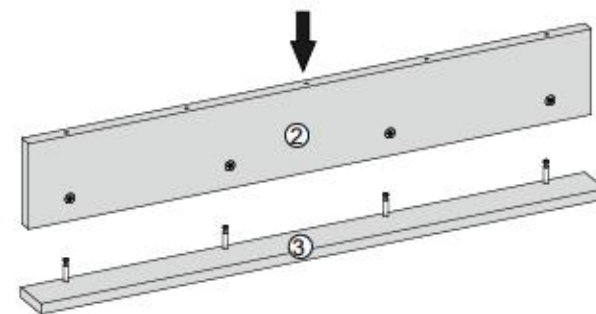
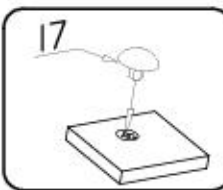
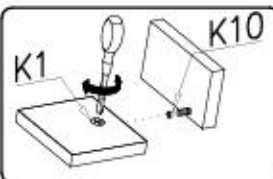

I7



x4

IV

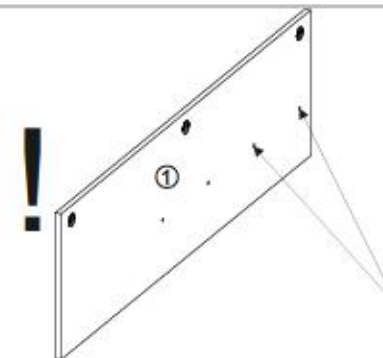
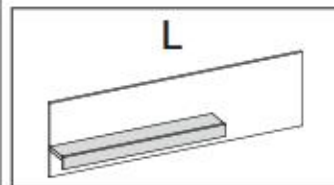

A1

ø7x50

x4

W2

x1

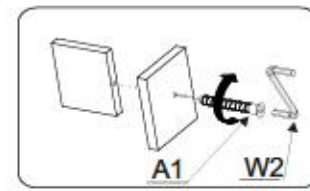
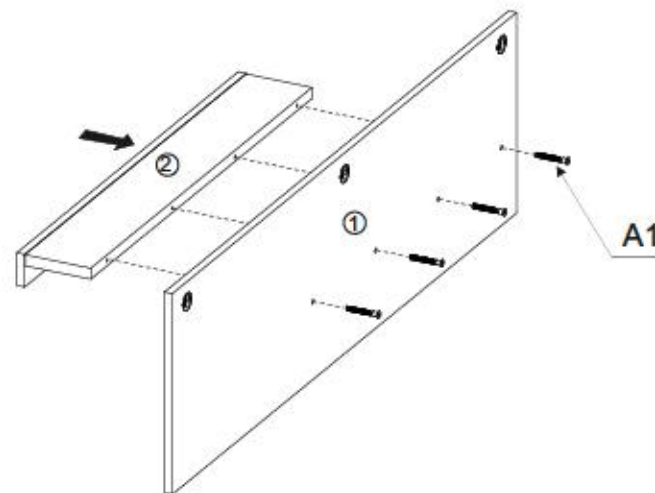
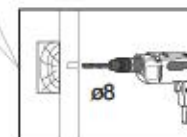

5/8

CITY / GIRON 73



V

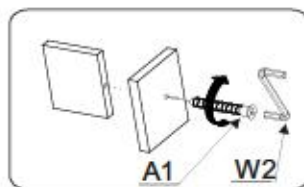
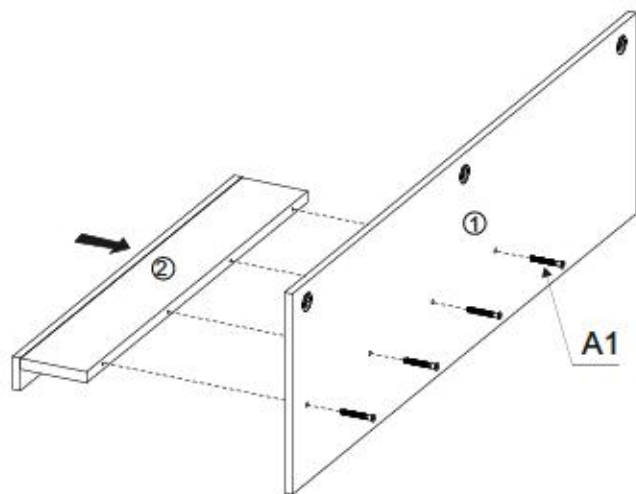
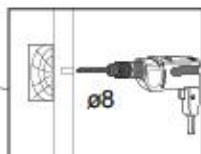
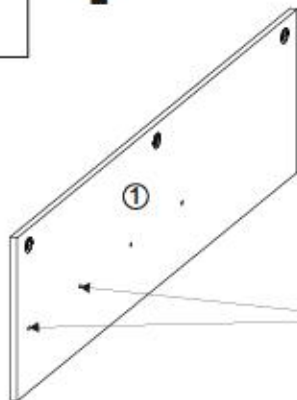
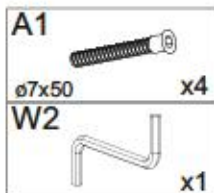
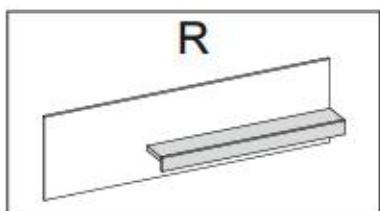

6/8

CITY / GIRON 73



VI

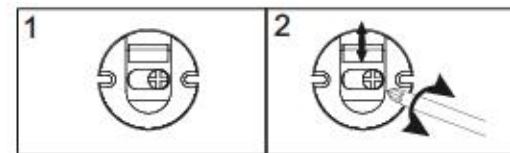
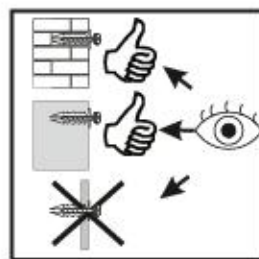
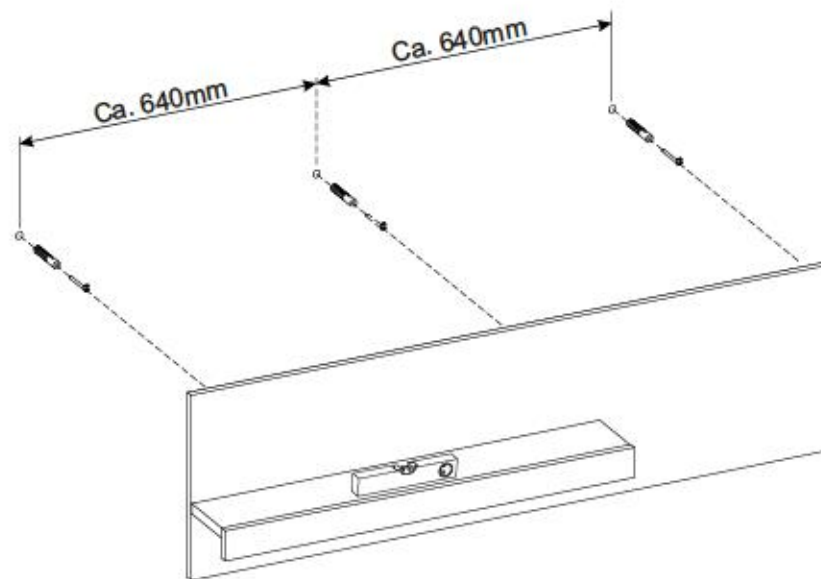
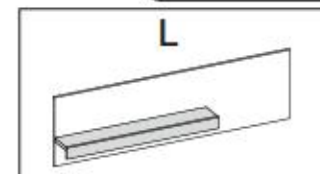
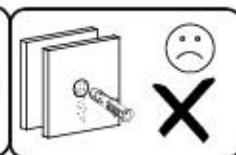
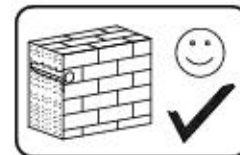

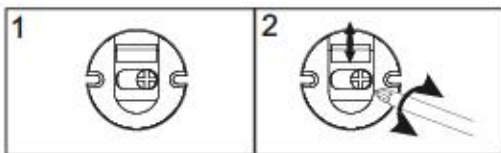
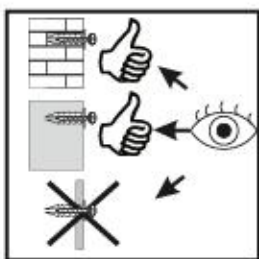
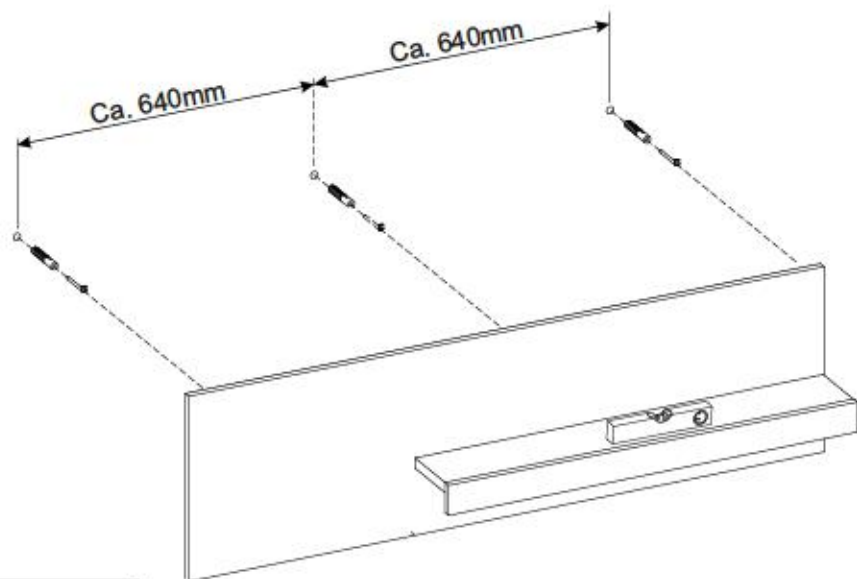
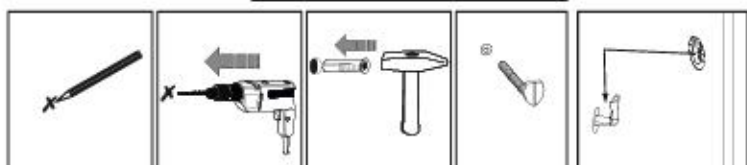
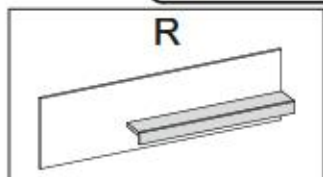
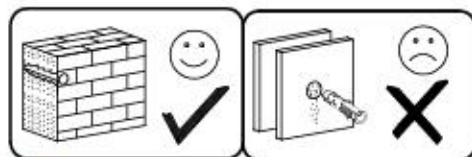

VII

Name • Nom • Nome • Naam • Nazwa • Jméno
• Názov • Név • Denumire • Isim • Имя

Nr • No • N° • Номер • Č • Sz

Typ • Type • Tip • Típus • Тíро • Tun

CITY / GIRON

--

73

D Utolsó díjazásunk: Ez Besztelapella
Sólym írásban cím: Besztelapella, írásban írásban cím: Besztelapella
direkt an die unterstehende Adresse mailen. Wir können allerdings
nur Besztelapella auf diesem Wege verschicken. Sollten Sie eine
andere Besztelung an Ihren Wohnort haben, so wenden Sie
sich bitte direkt an Ihr Möbelhaus.

GB Our direct order service for fitting
If a fitting part is missing, you can e-mail this service card directly
to the address below. However, we can only send fitting parts in
this way. If you have any other issues for completion concerning
your item of furniture, please contact your furniture store directly.

CZ Naše přímé služby pro kování
Chybí-li vám nějaký díl z kování, můžete tuto službu rovnou odeslat
e-mailem přímo na níže uvedenou adresu. Touto cestou však
můžeme isadit jen díly kování. Pokud byste měli nějaký jiný problém
s výrobkem, obraťte se přímo na svého prodejce nábytku.

F Bien utiliser la notice de montage
Si vous remarque une erreur, veuillez envoyer directement la présente
carte service l'adresse e-mail indiquée ci-dessous. Cependant, ceci
ne permet uniquement d'envoyer des éléments. Pour tout autre type
de problème concernant votre meuble, veuillez contacter
directement votre magasin d'aménagement.

I Il nostro servizio diretto per l'ordine della lavorazione
Qualora Vi dovesse mancare un pezzo di fissaggio, allora Vi
preghiamo di inviare questa carta di servizio immediatamente
all'indirizzo sottostante. Possiamo inviare i pezzi di fissaggio
solamente per mezzo di questo procedimento. Qualora dovesse
avere qualche altro problema in merito al mobile, allora Vi
preghiamo di rivolgerVi direttamente al Vostro Negozio di mobili.

BG Нашата директна услуга за облич
Ако липовата част от комплектта, потърсете настоящата
сервисна карта и я изпратете на е-мил адреса, посочен
по-долу. Тя може да бъде използвана за доставяне само на липвава
част от облича. Ако установите други дефекти по
мебелта, се свържете директно с облича на мебелите си.

NL Onze directie voor losse onderdelen
Wanneer er een onderdeel ontbreekt, kunt u deze aanvragen
direct aan onderstaand e-mailadres sturen. Wij kunnen helaas geen
weg e-mail aan losse onderdelen vaststellen. Mocht u een ander
probleem met een meubel hebben, verzoeakt u contact op te
nemen met uw meubeldealer.

PL Nasz bezpośredni serwis części montażowych
Jeżeli brakuje części koniecznych do montażu, prosimy o przesłanie
ni jej bezpośrednio na poniższy adres e-mailowy.
W ten sposób możemy przesłać jedynie brakujące części.
W przypadku innych problemów dotyczących mebla, prosimy o kontakt
z naszym meblowcem, w którym został dokonany zakup.

HR Servis za dijelove
U slučaju da nedostaje neki od dijelova potrebno vam da na dolje
navedenu mail adresu pošaljete ovaj servisni kartica. Na ovaj način
možu se dostaviti samo dijelovi. U slučaju da imate dodatne prigovore
vezane uz kupovnu namještaju molimo vas da se obratite bravno
trgovini namještaja gdje je isti kupljen.

HU Direktbesztelapella varrásokhoz
Ha hiányzik egy varrás, ezt a kórhelyt közvetlenül elküldhet az
alább található címre. Azonban csak varrásokhoz tudunk így
küldeni. Amennyiben másféle problémák állnak fenn a bútorteljesítéssel,
így forduljon közvetlenül a bútorteljesítőhöz.

SK Naše přímé služby pro částí kování
Ak by Vám chýbala niekajá časť kování, môžete poslať
túto službu rovnou priamo na nižšie uvedenú
adresu. Cieľou kování máme poslať iba týchto kování.
Ak by ste mali iný problém s výrobkom, obráťte sa
priamo na váš predajcu nábytku.

SLO Naše direktno usluga za dijelove
Da vam manjka kakikoli delov, lahko to namalo lahko pošljete
po e-pošti direktno na spodnji naslov. Po to pošljete lahko
samo samo dijelove. Če imate kakikoli dodatni problem
povzeto iz nakupa namještaja, molimo vas da se obratite
bravno trgovini namještaja, kjer je bil kupljen.

RO Serviciu de servicii directe pentru accesorii
In cazul in care va lipsesc o parte din accesorii, puteti sa trimitemi
direct acest card de servicii prin e-mail la adresa de mai jos. Noi
nu putem expedia piesa de la comenzi si decizi pe aceasta cale.
De la un alt tip de reclamație referitoare la piesa de mobilă si
atunci va rugăm să vă adresați direct la magazinul dvs. de mobilă.

RUS Наш прямой сервис для поставки фурнитуры
Если окажется, что Вам не хватает того или иного элемента
фурнитуры, Вы можете отправить этот сервисный карту по адресу
непосредственно на нижеприведенный адрес электронной
почты. Однако, таким образом мы можем отправить лишь
фурнитуру. Если же у Вас возникнут иные проблемы относительно
карты при покупке мебели, пожалуйста, обращайтесь
непосредственно в организацию, осуществляющую продажу.

S Vår direkte tjena för besztelapella
Om du saknar en besztelapella del du skicka detta servicekort direkt
till e-postadressen som anges nedan. Tjänst för att skicka är den enda
mätt gjorda till skicka besztelapella. Om du har några andra
problem med ditt köpta möbelsäck, vänligen kontakta ditt möbelsäck direkt.

ES Nuestro servicio directo para accesorios
Si le falta algún accesorio, puede enviar esta tarjeta de servicio directamente
a la siguiente dirección. No obstante, por esta vía solo podemos
enviar accesorios. Si tiene alguna otra cuestión sobre su mueble, consulte
directamente con su mueblería.

TR Doğrudan hizmet için doğrudan
Bir aksesuar eksikliği varsa, lütfen doğrudan aşağıdaki e-mail adresine
doğrudan mail ile ulaşabilirsiniz. Sadece bu yolla doğrudan aksesuarlar
Möbelenize başka aksesuarlar eklemek için doğrudan mobilya mağazanızla
iletilmelidir.

nr	L [mm]	B [mm]	T [mm]	Wenge	Colt
1	1400	400	16	1	1/1
2	900	134	16	1	1/1
3	902	65	16	1	1/1

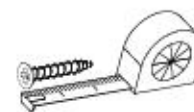
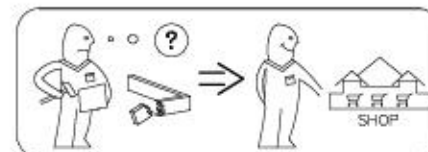
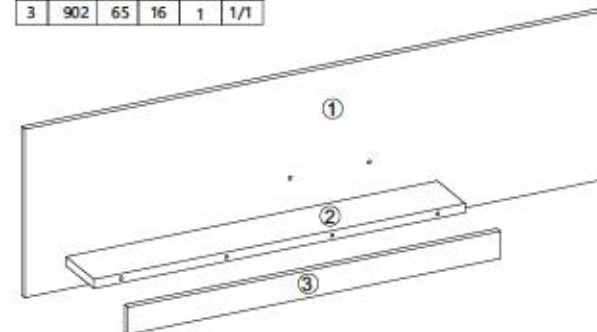

A1 Ø7x50 X...	W2 X...	G52 5x11 X...
P10 X...	I7 X...	K1 X...
K10 X...		

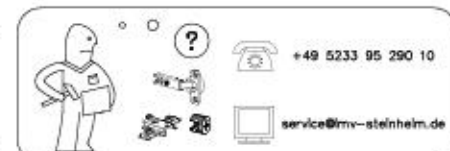

+49 5233 95 290 10

service@mv-steinheim.de