

- Ⓛ Montageanleitung
- Ⓝ Handleiding voor de montage
- Ⓜ Montaj talimat
- ⓕ Notice de montage
- Ⓒ Montážní návod
- ⓗ Szerelési útmutató
- ⓖ Assembly Instructions
- Ⓟ Instrukcja montażu
- Ⓡ Инструкции по монтажу
- Ⓡ Istruzioni di montaggio
- Ⓢ Návod na montáž
- Ⓡ Instrucțiuni de montaj
- ⓔ Instrucciones de montaje
- Ⓡ Montaj Talimat

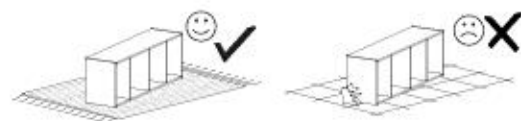

nr	L [mm]	B [mm]	T [mm]	Menge	Coll
1	350	300	16	1	1/1
2	350	300	16	1	1/1
3	968	266	16	1	1/1
4	962	254	16	1	1/1
5	862	100	16	1	1/1
6	962	344	16	1	1/1
7	968	332	16	1	1/1

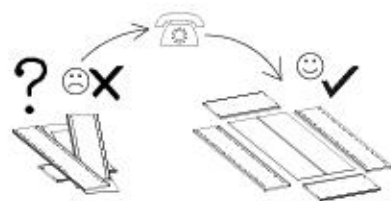
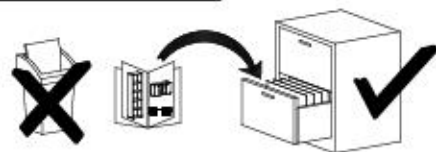
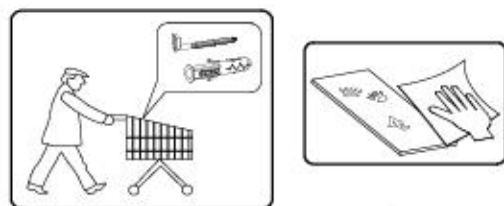
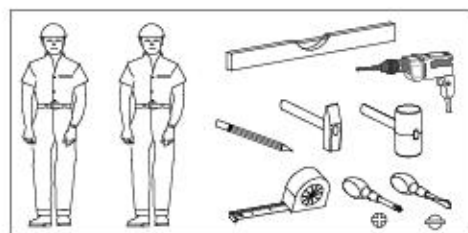
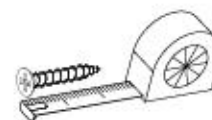
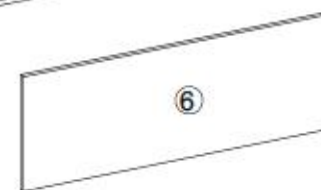
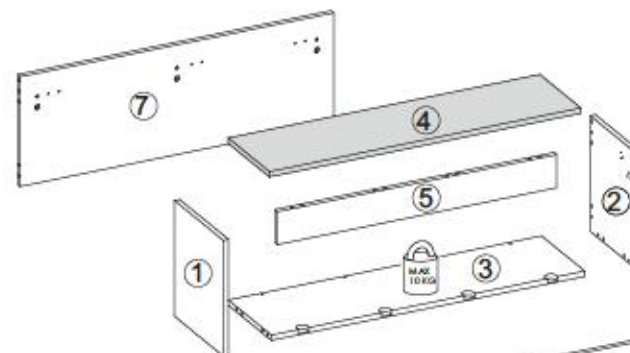

B1 ø8x35 x14	I7 x8	K1 x16	K10 x16	F4 x2
D4 x2	G34 3,5x16 x4	G52 5x11 x6	P10 x3	C6 x2
C16 80N x2	C17 60N x2	C20 x4	I8 x3	Q2 x3

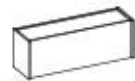

I

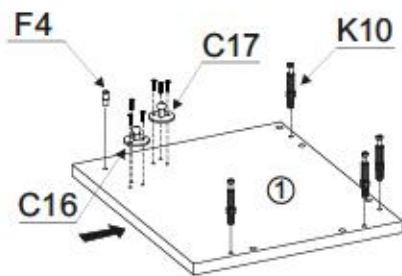

F4



x2

K10



x8

C16

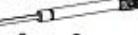

80N

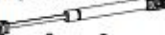

x2

C17

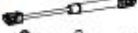

60N



x2

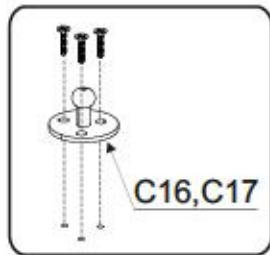
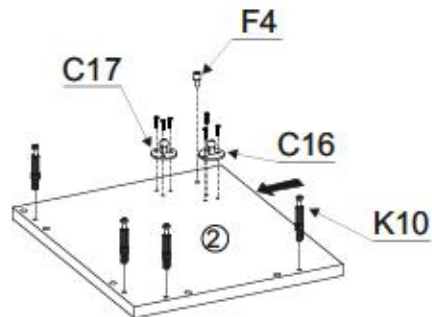

C16,C17

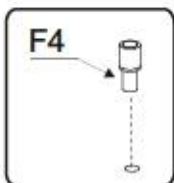

F4



II

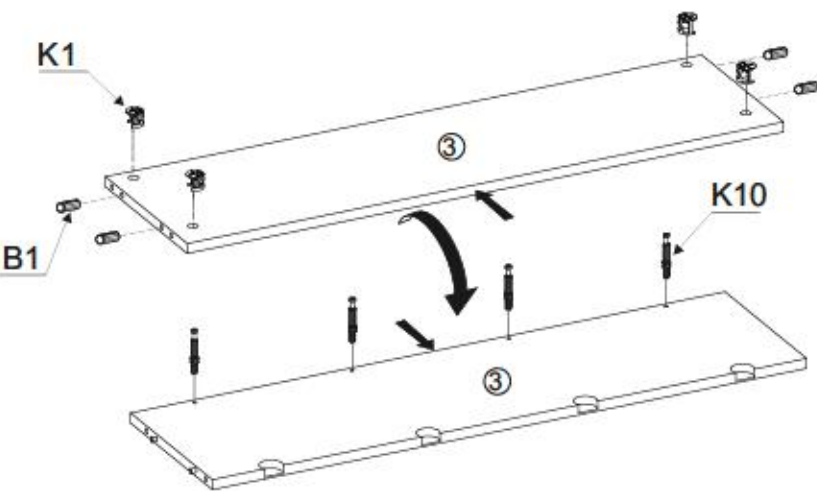

K10



x4

B1



x4

K1



x4

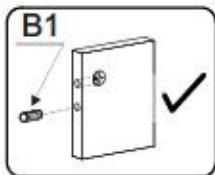

B1

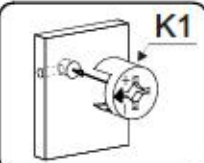

K1

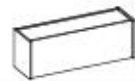

III

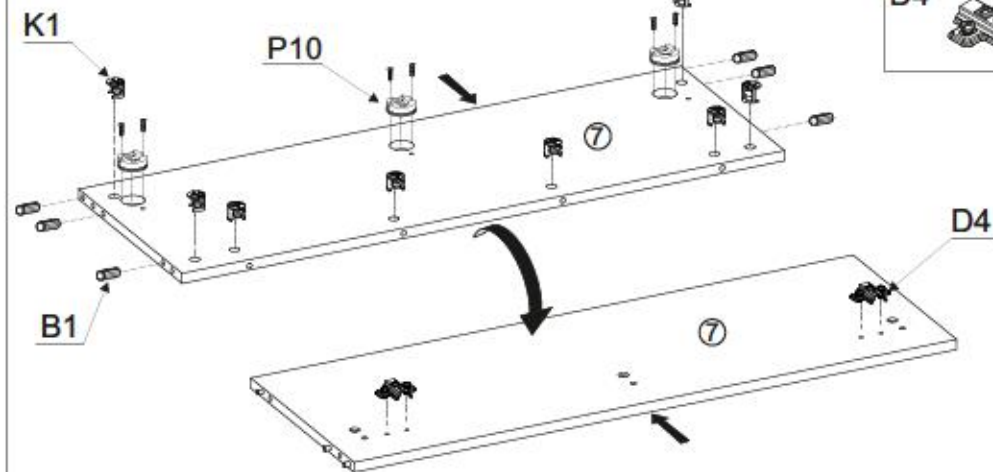

B1



ø8x35

x6

K1



x8

G52



5x11

x6

P10



x3

D4



x2

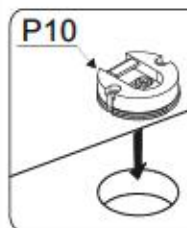

P10

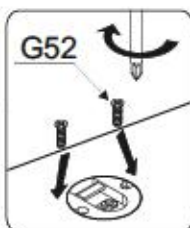

G52

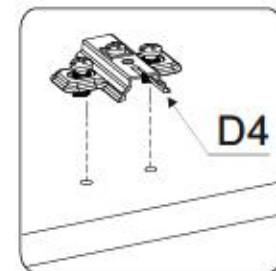
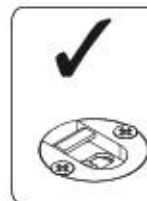

D4

IV

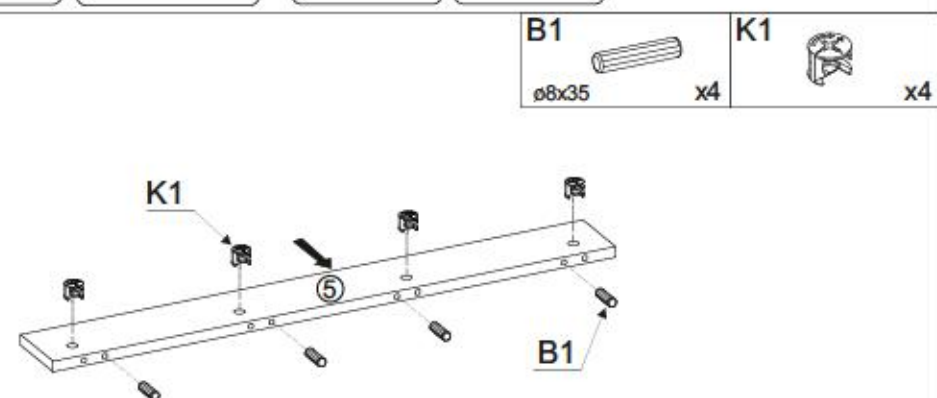

B1



x4

K1



x4

5/13

CITY / GIRON 08



V

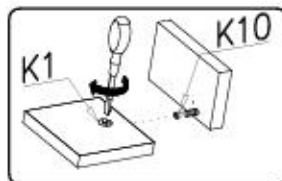
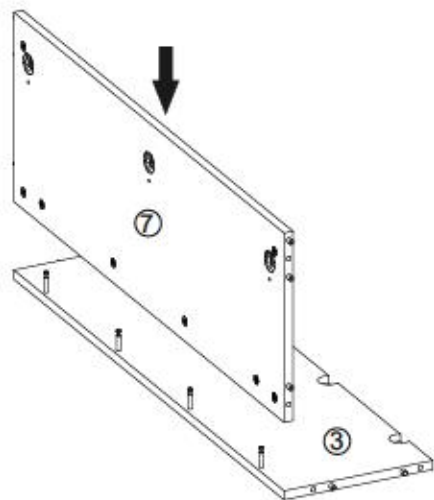

VI

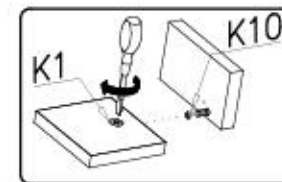
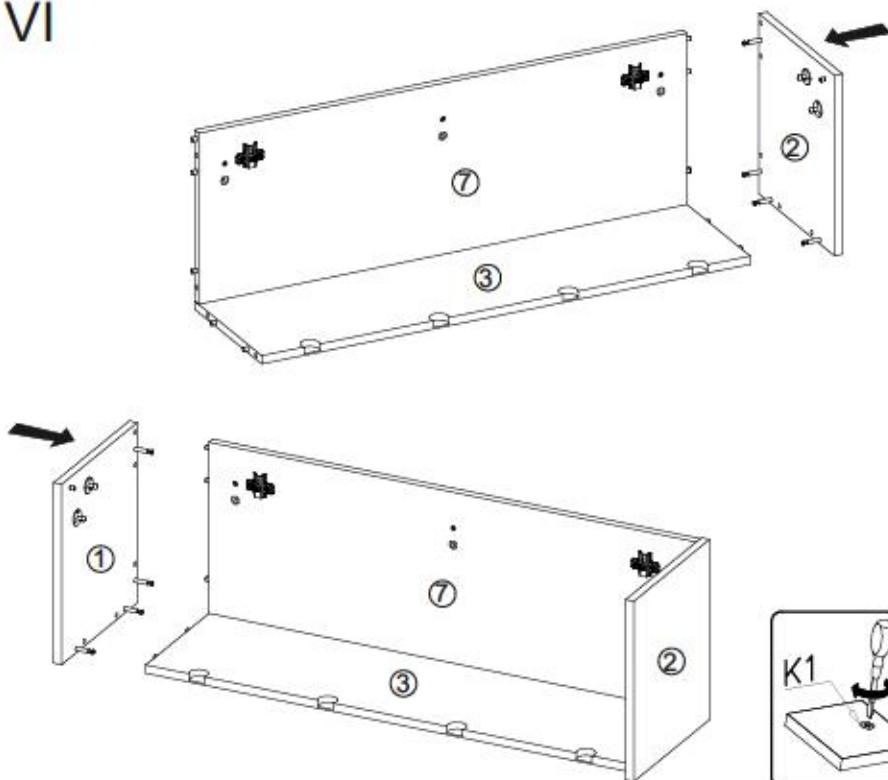

6/13

CITY / GIRON 08



VII

G34
3,5x16 x4

C20 x4



E6 x2



C16 x2

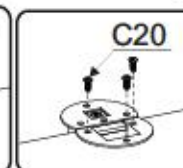
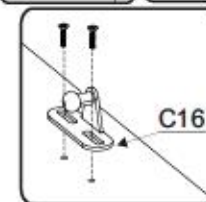
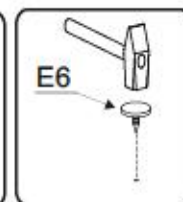
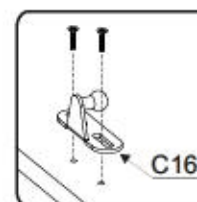
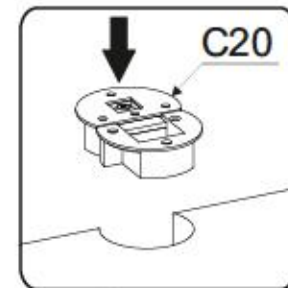
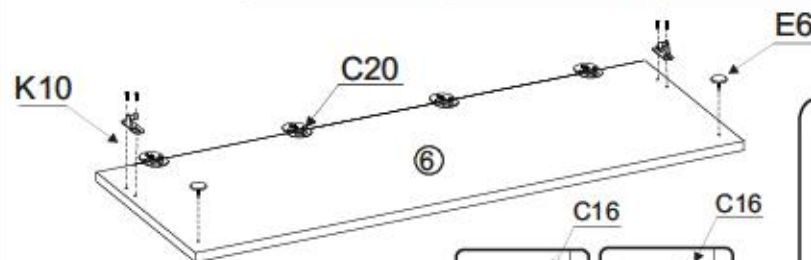

VIII

K10 x4



C6 x2



E6 x2



G34 3,5x16 x4



C17 x2

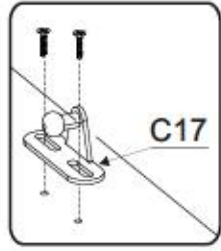
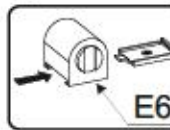
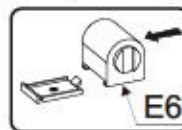
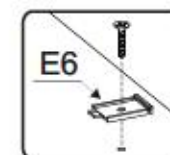
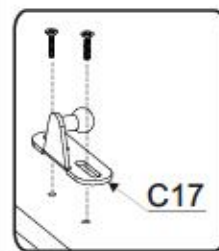
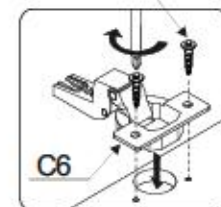
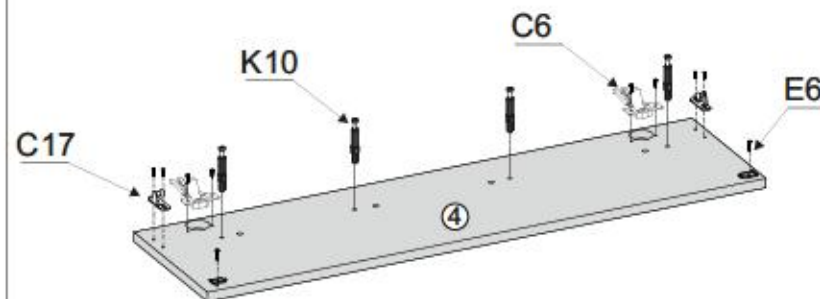

7/13

CITY / GIRON 08



IX

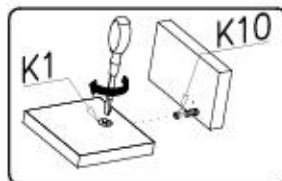
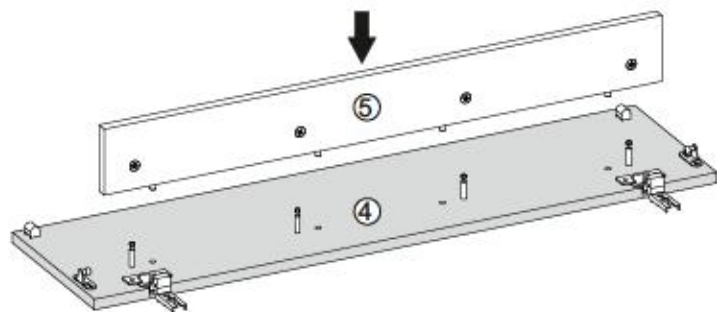

X

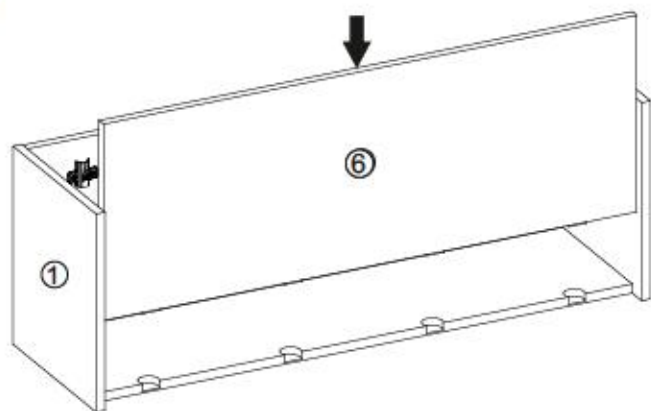

C20 x4

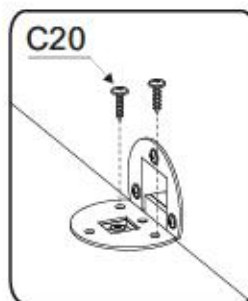
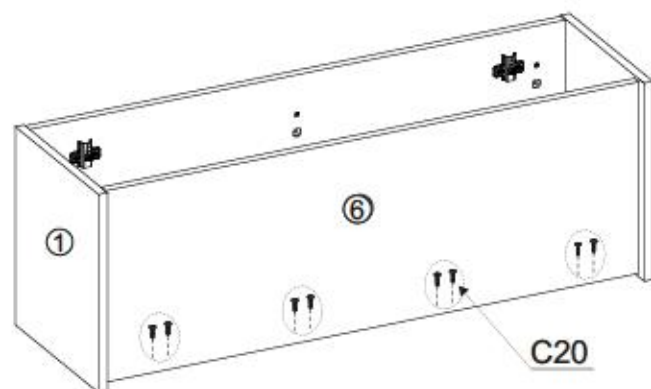

8/13

CITY / GIRON 08



XI

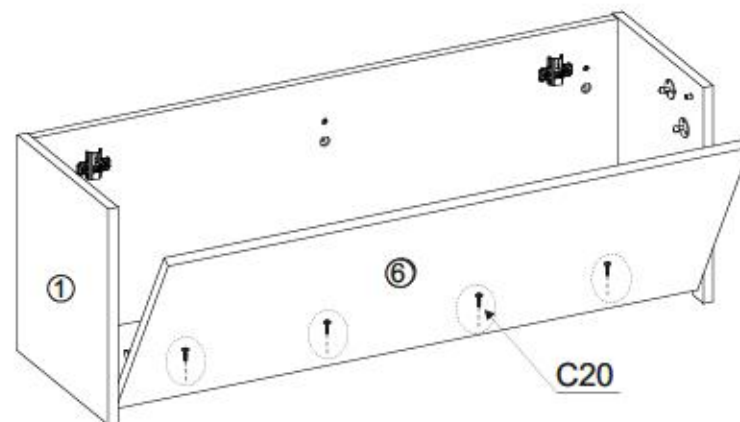

C20 x4

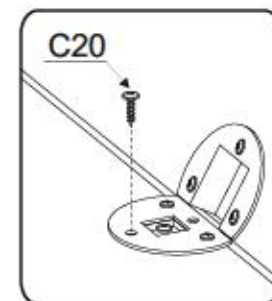

XII

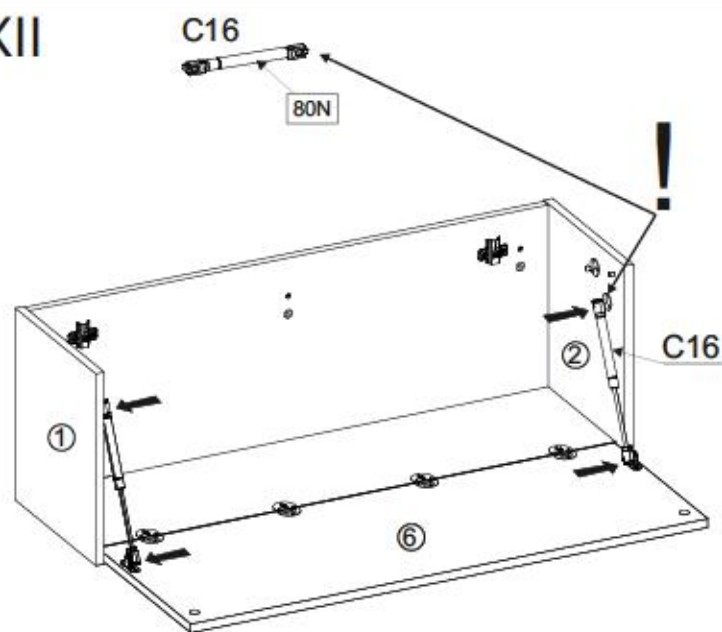

C16 80N x2

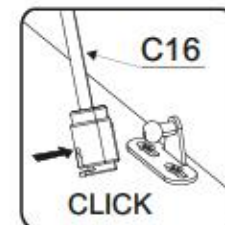
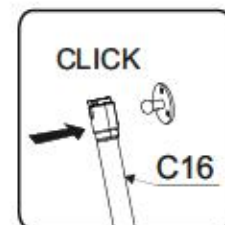

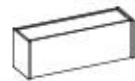

XIII

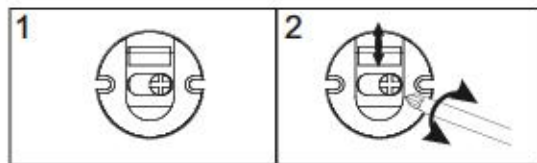
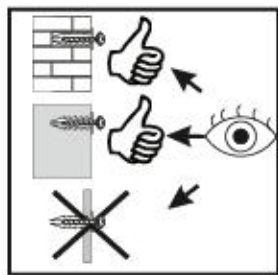
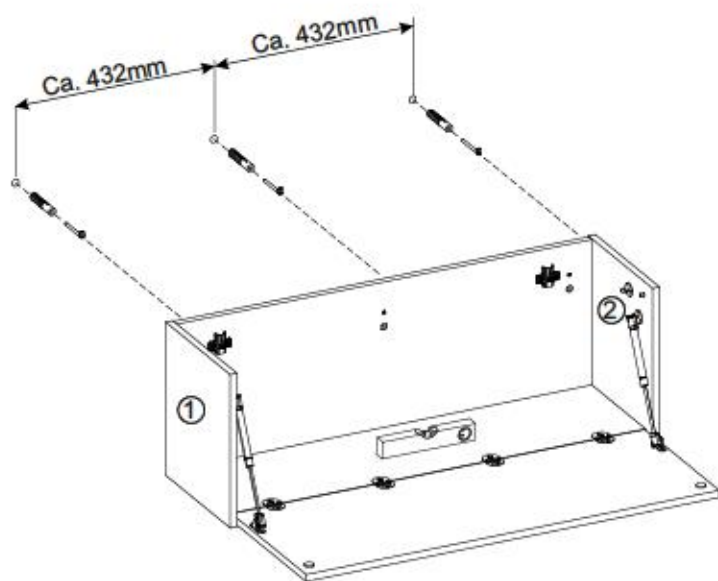
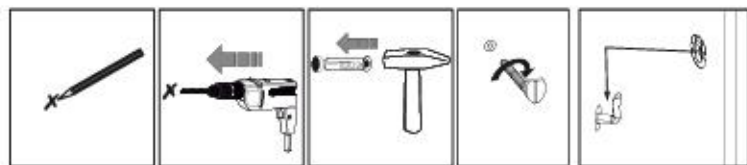

XIV

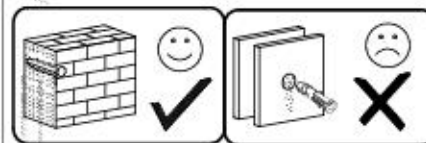
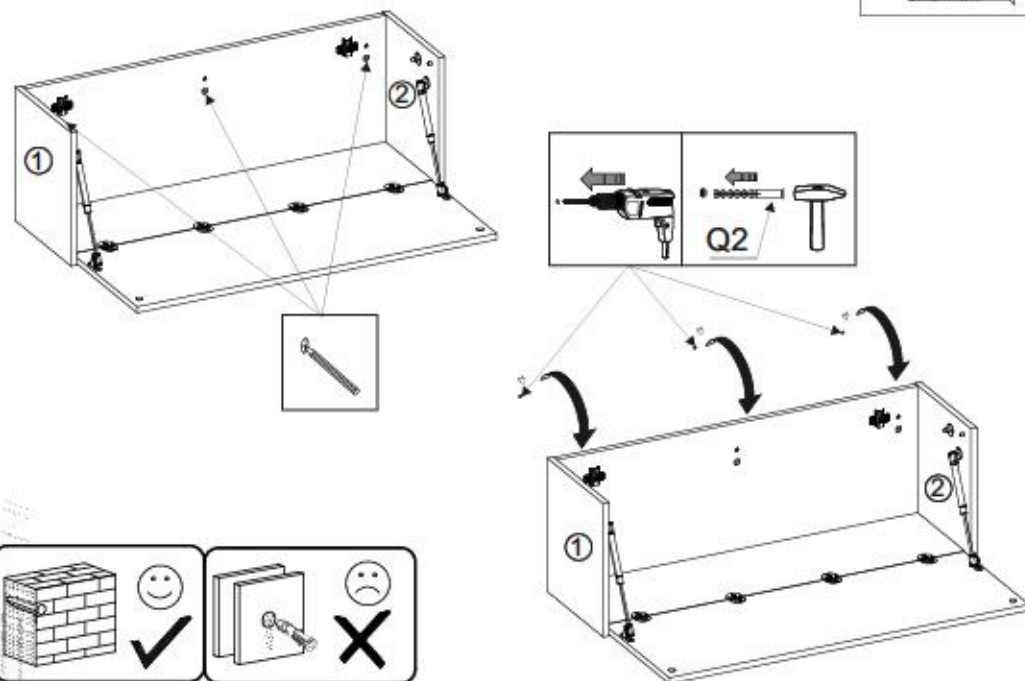
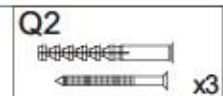

XV

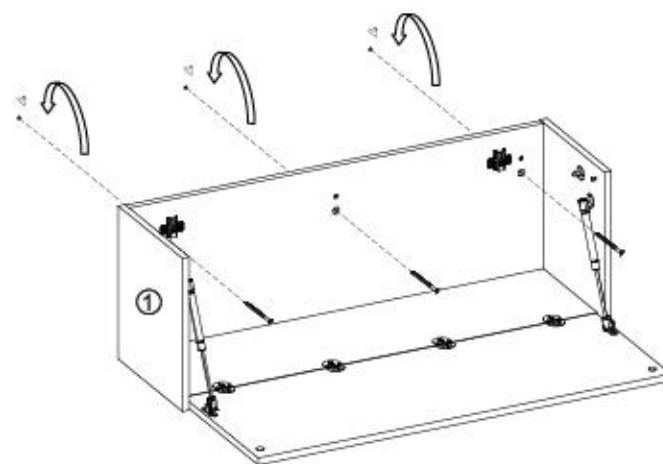
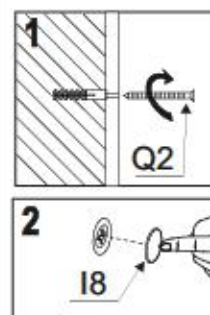



XVI

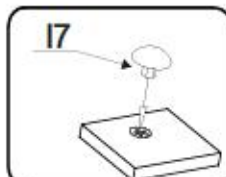
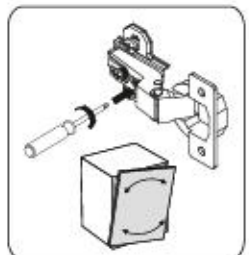
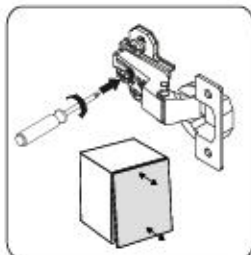
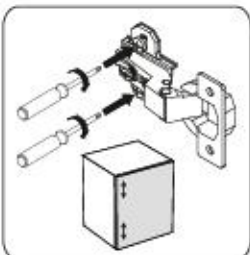
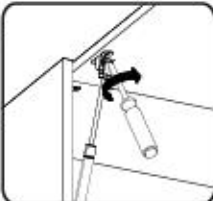
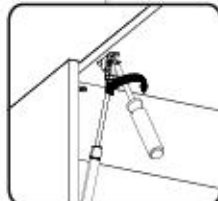
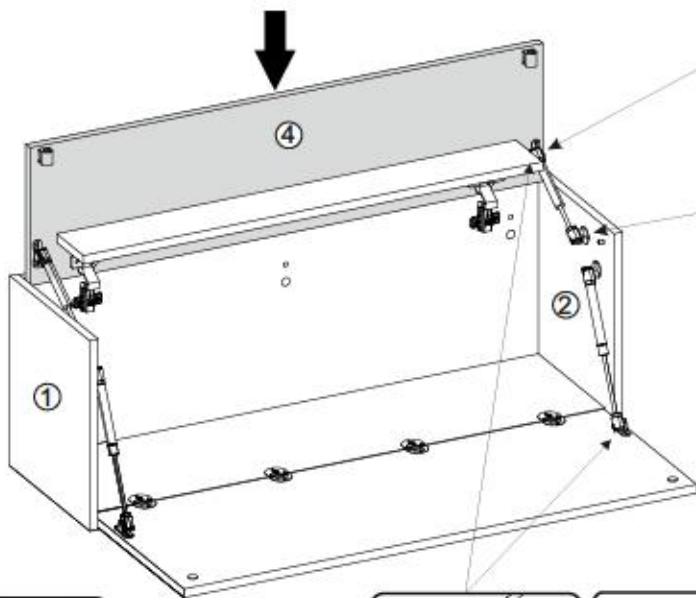
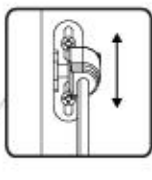
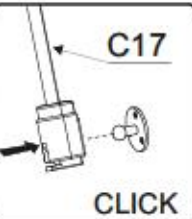
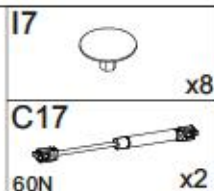
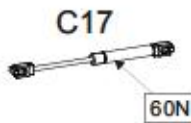
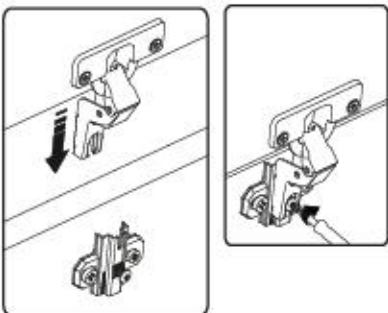

Name • Nom • Nome • Naam • Nazwa • Jméno • Νόμος • Νέν • Denimire • Isim • Имяние
 Nr • No • N° • Номер • Č • Sz
 Typ • Type • Tip • Típus • Tipo • Tun

CITY / GIRON

--

08

D Lirene Dientverlening. De Beschrijver
 Sollen Ihnen ein Beschlagteil fehlen, können Sie diese Servicekarte
 direkt an die untenstehende Adresse mailen. Wir können allerdings
 nur Beschlagteile auf diesem Wege verschicken. Sollten Sie eine
 andere Beseitigung an Ihrem Möbelstück haben, so wenden Sie
 sich bitte direkt an Ihr Möbelhaus.

GB Our direct order service for filling
 If a fitting part is missing, you can e-mail this service card directly
 to the address below. However, we can only send fitting parts in
 this way. If you have any other issues for complete dismantling
 your item of furniture, please contact your furniture store directly.

CZ Naše příloha slouží pro kování
 Pokud Vám nějaký díl chybí, můžete tuto servisní kartu odeslat
 e-mailem přímo na níže uvedenou adresu. Touto cestou však
 můžeme odeslat jen díly kování. Pokud byste měli nějaký jiný problém
 s nábytkem, obraťte se přímo na svého prodejce nábytku.

F Bien étudier la notice de montage
 Si vous remarque une erreur, veuillez envoyer directement la présente
 carte service à l'adresse e-mail indiquée ci-dessous. Cependant, ceci
 nous permet uniquement d'envoyer des ferrures. Pour tout autre type
 de réclamation concernant votre meuble, veuillez contacter
 directement votre magasin d'ameublement.

I Il nostro servizio diretto per i difetti della lavorazione
 Qualora Vi dovesse mancare un pezzo di fissaggio, allora Vi
 preghiamo di inviare questa carta di servizio immediatamente
 all'indirizzo sottostante. Possiamo inviare i pezzi di fissaggio
 solamente per mezzo di questo procedimento. Qualora dovesse
 esservi qualche altro problema in merito al mobile, allora Vi
 preghiamo di rivolgerVi direttamente al Vostro Negozio di mobili.

BG Нашата директна услуга за обвив
 Ако липсват части от комплект, потърсете настоящата
 сервисна карта и ни изпратете на e-mail адреса, посочен
 по-долу. Тя позволява изпращане на доставени части, например
 аксесоари от обвив. Ако установите други дефекти по
 мебелта, би съветваме да се обвързете със мебелната
 компания/магазин, от който сте закупили стоката.

NL Onze directie voor losse onderdelen
 Wanneer er een onderdeel ontbreekt, kunt u deze servicekaart
 direct aan onze afdeling e-mailadres sturen. Wij kunnen langzame
 weg echter alleen losse beslagdelen verzenden. Mocht u een ander
 probleem met een meubel hebben, verzeken wij u contact op te
 nemen met uw meubeldealer.

PL Nasz bezpośredni serwis części montażowych
 Jeżeli brakuje części koniecznych do montażu, prosimy o przesłanie
 nam niniejszej karty serwisowej na niżej podany adres e-mailowy.
 W ten sposób możemy przesłać: Pełniaku tylko brzołogę czepki.
 W przypadku innych szkłańców dotyczących mebla, prosimy o kontakt
 z naszym meblowym, w którym został dokonany zakup.

HR Servis za otkove
 U slučaju da nedostaje neki od dijelova molimo vas da na dole
 navedenu mail adresu pošaljete ovaj servisni obrazac. Na ovaj način
 mogu se dostaviti samo otkovi. U slučaju da imate dodatne prigovore
 vezane uz kovanje namještaja molimo vas da se obratite bravno
 trgovini namještaja gdje je isti kupljen.

HU Direktrendelkérésnek vanatibok esetén
 Ha hiányzik egy vasalat, ezt a kártyát kitöltve küldje el az
 alább található címre. Azonban csak vasalatokat tudunk így
 küldeni. Amennyiben másféle problémát áll fel Önnek a meblével
 kapcsolatban, forduljon közvetlenül a bútortárolójához.

SK Náš priamy servis pre častí kování
 Ak by Vám chýbala nejaká časť kování, môžete poslať
 túto servisnú kartu priamo e-mailom na nižšie uvedenú
 adresu. Cieľom kování Vám poslať iba tieto kování.
 Ak by ste mali inú námietku ohľadom nábytku, obráťte sa
 priamo na Vašu predajňu nábytku.

SLO Naše direktno uslugovanje za otkove
 Če vam manjka kakšno okovje, lahko to servisu karico pošljete
 po e-pošti direktno na spodnji naslov. Po tej poti vam lahko
 pošljemo samo okovje. Če imate kakršnakoli kakšen drug del
 pohištva, se obrnite neposredno na vašo trgovino pohištva.

RO Serviciu la noi este direct pentru furnizarea
 În cazul în care vă lipsește o piesă de fierare, puteți să trimiteți
 direct această card de serviu prin e-mail la adresa de mai jos. Noi
 nu putem expedia piesa de fierare decât pe această cale.
 Dacă aveți o altă reclamație referitoare la piesa de mobilier,
 atunci vă rugăm să vă adresați direct la magazinul dvs. de mobilier.

RUS Наш прямой сервис для поставки фурнитуры
 Если вы заметили, что Вам не хватает того или иного элемента
 фурнитуры, Вы можете отправить сервисную карту по адресу
 непосредственно на нижеприведенный адрес электронной
 почты. Однако, таким образом мы можем переслать лишь
 фурнитуру. Если же у Вас возникли иные претензии относительно
 прочей мебели, пожалуйста, обращайтесь, соответственно,
 непосредственно в магазин, осуществляющий продажу.

S Vår direkte tjena för beslagdelar
 Om du saknar en beslagdel kan du skicka detta servicekort direkt
 till e-postadressen som anges nedan. Tänk på att detta är den enda
 möjligheten att skicka beslagdelar till dig. Om du vill reklamera ditt
 möbel av annan anledning än att du saknar ett beslagdel, direkt,
 kontakta ditt möbelhus.

ES Nuestro servicio directo para accesorios
 Si le falta algún accesorio, puede enviar esta tarjeta de servicio directamente
 a la siguiente dirección. No obstante, por este método solo podemos
 enviar accesorios. Si tiene alguna otra objeción sobre su mueble, consulte
 de directamente con su mueblería.

TR Doğrudan lık doğrudan teslimat
 Bir donatı eksikliği bu servise kartını doğrudan aşağıdaki buharan adrese
 doğrudan mail ile iletilebilir. Ancak bu yolla sadece donatı teslimatı
 mümkündür. Mobilyanızda başka şikayetleriniz varsa lütfen doğrudan mobilya satışçınıza
 derişin.

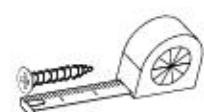

E6	F4	B1
x...	x...	x...
I7	K1	K10
x...	x...	x...
C6	D4	G34
x...	x...	x...
G52	P10	C20
x...	x...	x...
5x11	C17	Q2
x...	x...	x...
C16		
80N		
x...		
I8		
x...		



Name • Nom • Nome • Naom • Nazwa • Jméno • Názov • Név • Denumire • Isim • Имя
CITY / GIRON

Nr • No • N° • Номер • Č • Sz • Typ • Type • Tip • Трpus • Тipo • Tun
 --- 08

D Unsere Dienstleistungen für Beschädigte
 Sollten Ihnen ein Beschädigter fallen, können Sie diese Servicekarte direkt an die untenstehende Adresse mailen. Wir können sie auf den nur Beschädigte auf diesem Wege verschicken. Sollten Sie eine andere Beseitigung an Ihrem Möbelstück haben, so wenden Sie sich bitte direkt an Ihr Möbelhaus.

GB Our direct order service for fitting
 If a fitting part is missing, you can e-mail this service card directly to the address below. However, we can only send fitting parts in this way if you have any other contact for completion concerning your item of furniture, please contact your furniture store directly.

CZ Nahr přílohu služby pro kadeřní
 Chytl-li vám náhodou díl z kování, můžete tuto servisní kartu odeslat e-mailem přímo na níže uvedenou adresu. Touto cestou však můžete kontaktovat jen díly kování. Pokud byste měli nějakou jinou záležitost, obraťte se přímo na svého prodejce nábytku.

F En attendant la notice de montage
 Si vous manque une pièce, veuillez envoyer directement la présente carte service à l'adresse e-mail indiquée ci-dessous. Cependant, ceci nous permet uniquement d'envoyer des fixures. Pour tout autre type de réclamation ou notamment votre meuble, veuillez contacter directement votre magasin d'ameublement.

I Il nostro servizio di aiuto per il ordine dei fermettoni
 Qualora Vi dovesse mancare un pezzo di fissaggio, allora Vi preghiamo di inviarci questa carta di servizio immediatamente affinché esso arrivi subito. Possiamo inviare i pezzi di fissaggio solamente per mezzo di questo procedimento. Qualora dovete avere qualche altra reclamazione in merito al mobile, allora Vi preghiamo di rivolgerVi direttamente al Vostro Negozio di mobili.

BG Нашата директна услуга за обикол
 Ако ви липват части от комплекта, потърсете местонахождение на магазина и ни е изпратете на e-mail адреса, посочен по-долу. По този начин можем да доставим само необходимите елементи от обикол. Ако установите други дефекти по мебелите, Ви съветваме да се обадите или посетите магазина, от който сте закупили мебелите.

NL Onze directservice voor losse onderdelen
 Wanneer er een onderdeel ontbreekt, kunt u deze servicekaart direct aan onderstaand e-mailadres sturen. Wij kunnen langzame deze weg echter alleen bestaande verstuuren. Mocht u een ander probleem aan uw meubel hebben, verzoeken wij u contact op te nemen met uw meubel dealer.

PL Nasz bezpośredni serwis części montażowych
 Jeżeli brakuje części konstrukcyjnych do montażu, prosimy o przesłanie nam niniejszej karty w celu dostarczenia na niniejszy adres e-mailowy. W ten sposób możemy przesłać Państwu tylko brakujące części. W przypadku innych reklamacji dotyczących mebla, prosimy zgłaszać je do swojego meblowego, w którym został dokonany zakup.

HR Servis za olovu
 U slučaju da nedostaje neki od dijelova molimo vas da na dolje navedenu mail adresu pošaljete naš servisni obrazac. Na ovaj način mogu se dostaviti samo olovi. U slučaju da imate dodatne prigovore vezane uz komad namještaja molimo vas da se obratite izravno trgovini namještaja gdje je isti kupljen.

HU Direktazi gátlakunk vasalok érvelés
 Ha hiányzik egy vasalat, ezt a kártyát kóvetlenül elküldheti az alábbi e-mail címre. Azonban csak azt tudunk elküldni így küldéssel. Amennyiben másfajta reklamációt kell benyújtani, kérem, forduljon kóvetlenül a boltiáruházhoz.

SK Náš priamy servis pre štít kováčok
 Ak by Vám chýbala nejaká časť kováča, môžeme poslať toto servisnú kartu poštou e-mailom na nižšie uvedenú adresu. Cieľ je kováče a vieme poslať iba týchto súčiastok. Ak by ste mali inú záležitosť ohľadom Vášho nábytku, obráťte sa priamo na Vašu predajňu nábytku.

SLO Náš direktni servis za delce kovanja
 Če vam manjka kakikoli delce kovanja, lahko to servisno kartico pošljete po e-pošti direktno na spodnji naslov. Po tej poti vam lahko pošljemo samo olovice. Če delite nekatere kakovostne druge delce pohištva, se obrnite neposredno na vašo trgovino pohištva.

RO Serviciul nostru direct pentru kováci
 În cazul în care vă lipsește o piesă de kováci e-mail cu lista de detalii direct acestei card de service prin e-mail la adresa de mai jos. Nu ni putem expedia piesa de feronerie decât pe această cale. Dacă aveți o altă reclamație referitoare la piesa de mobilier, atunci vă rugăm să vă adresați direct la magazinul de mobilier.

RUS Наш прямой сервис для поставок фурнитуры
 Если обнаружено, что Вам не хватает того или иного элемента фурнитуры, Вы можете отправить сервисную карту по факсу непосредственно на нижеуказанный адрес электронной почты. Однако, такие образцы мы сможем переслать лишь по факсу. Если же у Вас возникнут другие претензии относительно конструктивной мебели, пожалуйста, обращайтесь непосредственно в магазин, осуществляющий продажу.

S Měr direktní servis pro štít kováčů
 Om du mangler en beslagdel kan du skicka detta servicekortet direkt till beslagleveranten som anges nedan. Tänk på att detta är den enda möjligheten att skicka beslagdelar till dig. Om du vill klaga på din möbel av annan anledning måste du kontakta ditt möbelhus direkt.

ES Nuestro servicio directo para accesorios
 Si le falta algún accesorio, puede enviar esta tarjeta de servicio directamente a la siguiente dirección. No obstante, por este método solo podemos enviar accesorios. Si tiene el gura otra objeción sobre su mueble, consulte directamente con su mueblería.

TR Doğrudan loto dogudulen servisi
 Bir donanim aksuarini bulamazsaniz dogudulen degisik bir urun adresine dogudulen mail yollayabilirsiniz. Sadece bu yolla donanimi gidebilirsiniz. Mobilyenize bagli bileselerinizi vama kirlen dogudulen mobilya satilicinizla dogudulen.

nr	L[mm]	B[mm]	T[mm]	Menge	Coll
1	350	300	16	1	1/1
2	350	300	16	1	1/1
3	968	266	16	1	1/1
4	962	254	16	1	1/1
5	862	100	16	1	1/1
6	962	344	16	1	1/1
7	968	332	16	1	1/1

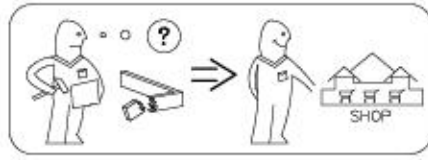
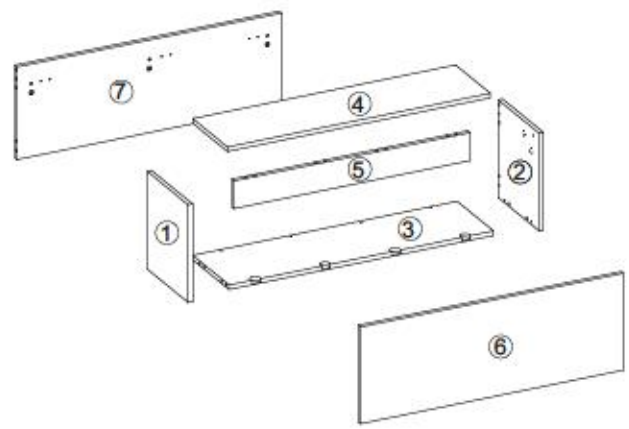

Modell: CITY / GIRON 46

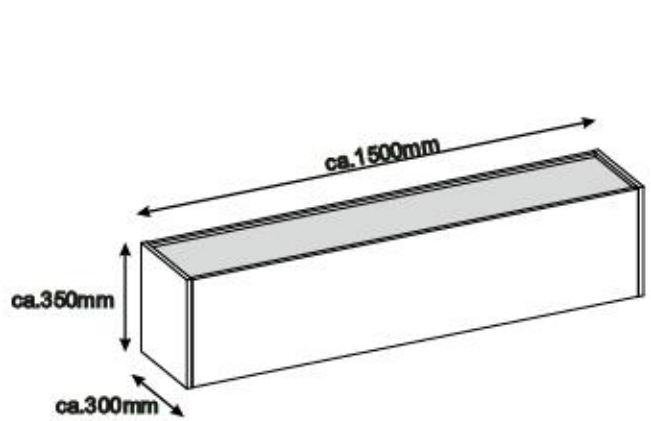

- (D)** Montageanleitung
- (NL)** Handleiding voor de montage
- (TR)** Montaj talimatı
- (F)** Notice de montage
- (CZ)** Montážní návod
- (HU)** Szerelési útmutató
- (GB)** Assembly Instructions
- (PL)** Instrukcja montażu
- (RU)** Инструкция по монтажу
- (IT)** Istruzioni di montaggio
- (SK)** Návod na montáž
- (RO)** Instrucțiuni de montaj
- (ES)** Instrucciones de montaje
- (TR)** Montaj Talimatı

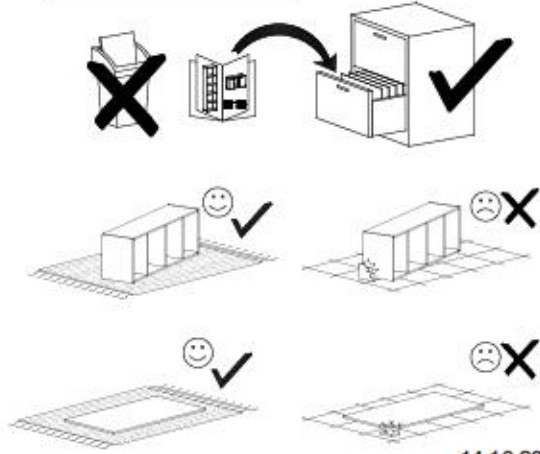
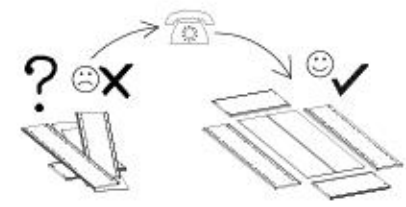
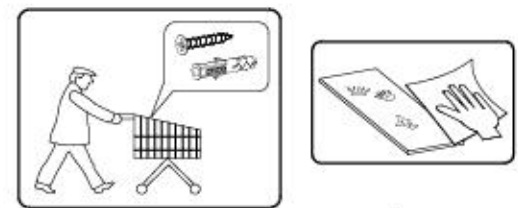
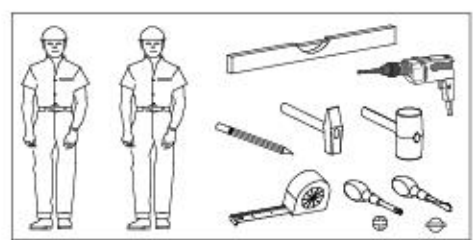



nr	l[mm]	h[mm]	t[mm]	Menge	Coll
1	350	300	16	1	1/1
2	350	300	16	1	1/1
3	305	100	16	1	1/1
4	1468	266	16	1	1/1
5	1468	283	16	1	1/1
6	1463	347	16	1	1/1
7	1468	332	16	1	1/1

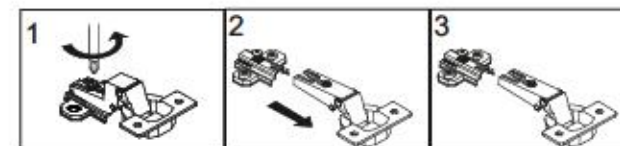
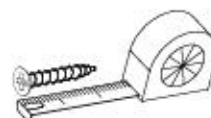
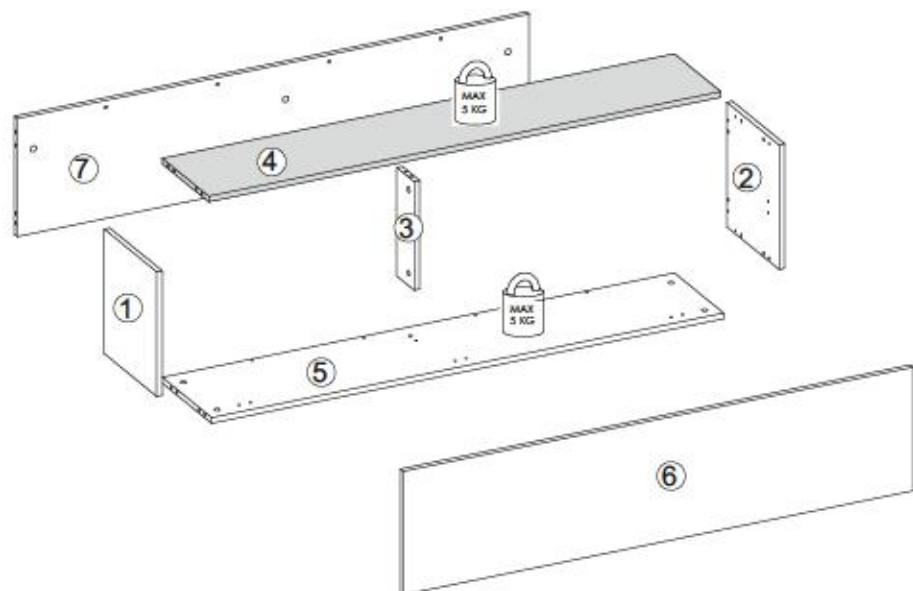

B1 ø8x35 x14	A1 ø7x50 x4	W2 x1	I7 x10	C10 x2
K1 x18	K10 x18	D6 x3	C1 x3	G34 3,5x16 x18
P10 x3	G52 5x11 x6	I8 x6	Q2 x3	



I

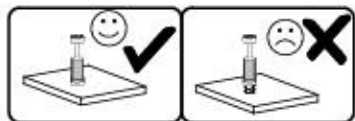
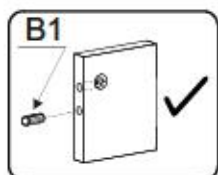
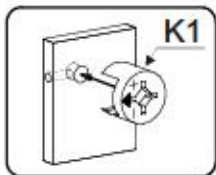
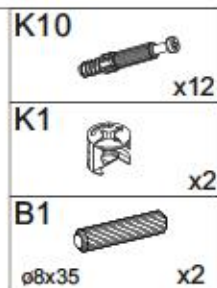
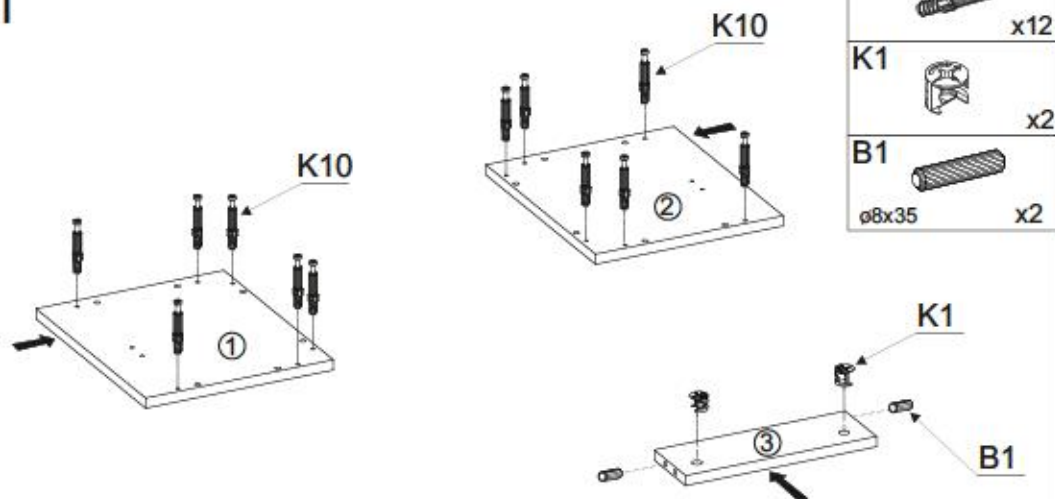

II

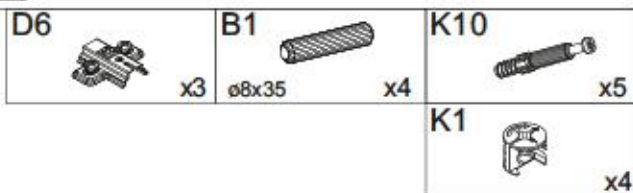
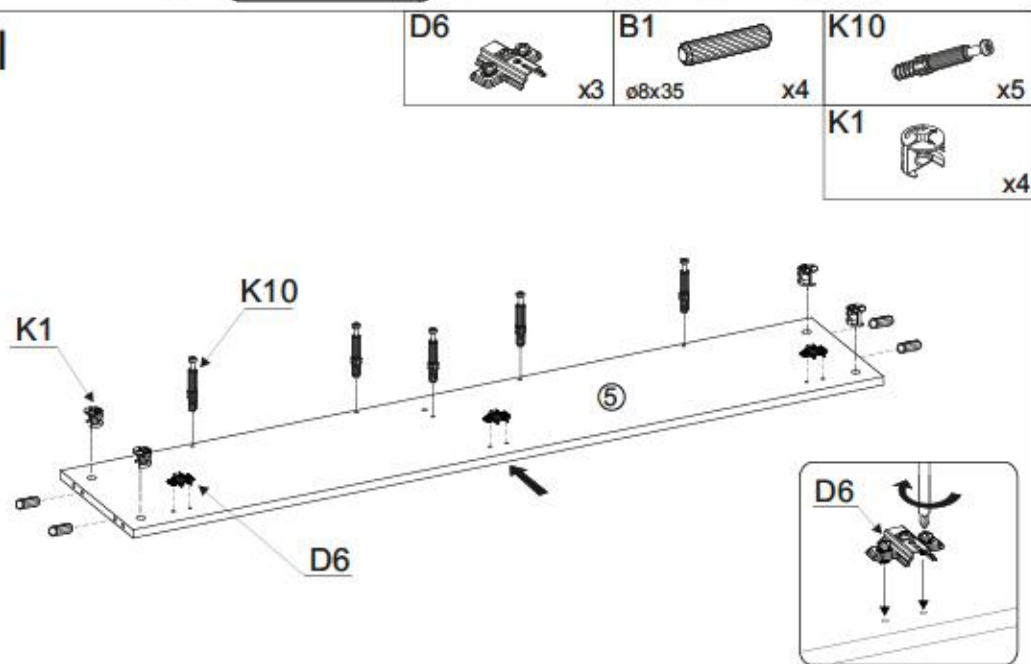

III

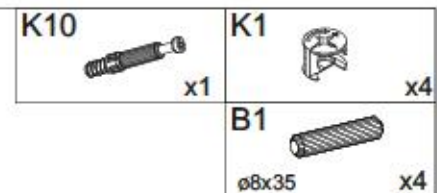
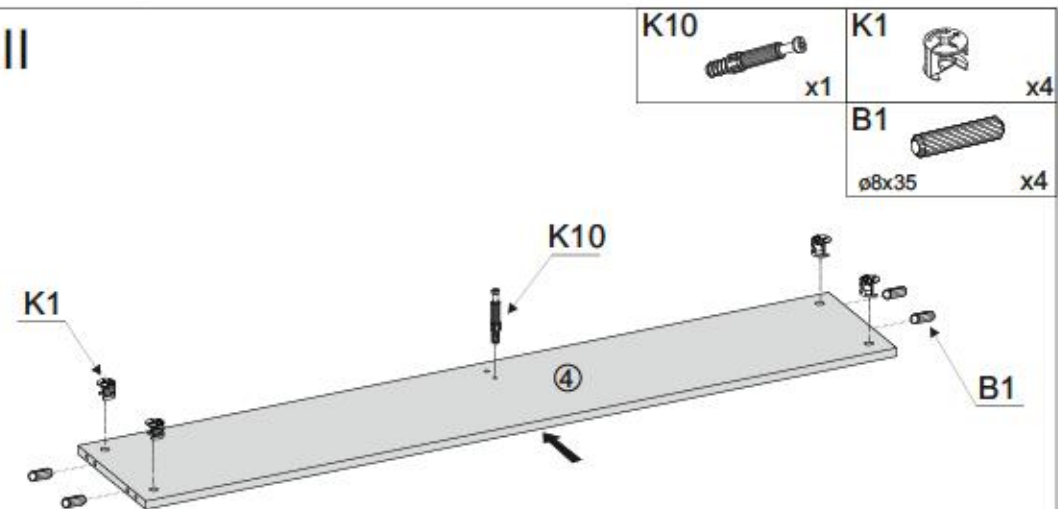

IV

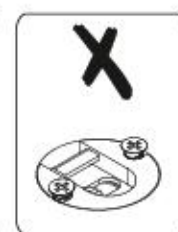
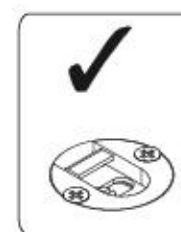
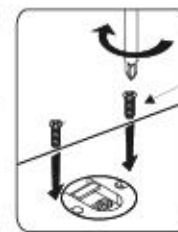
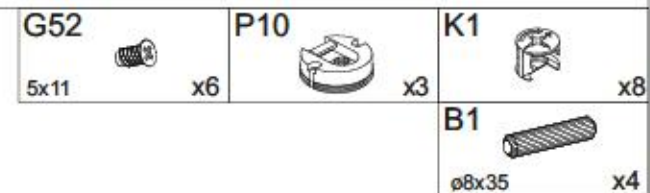
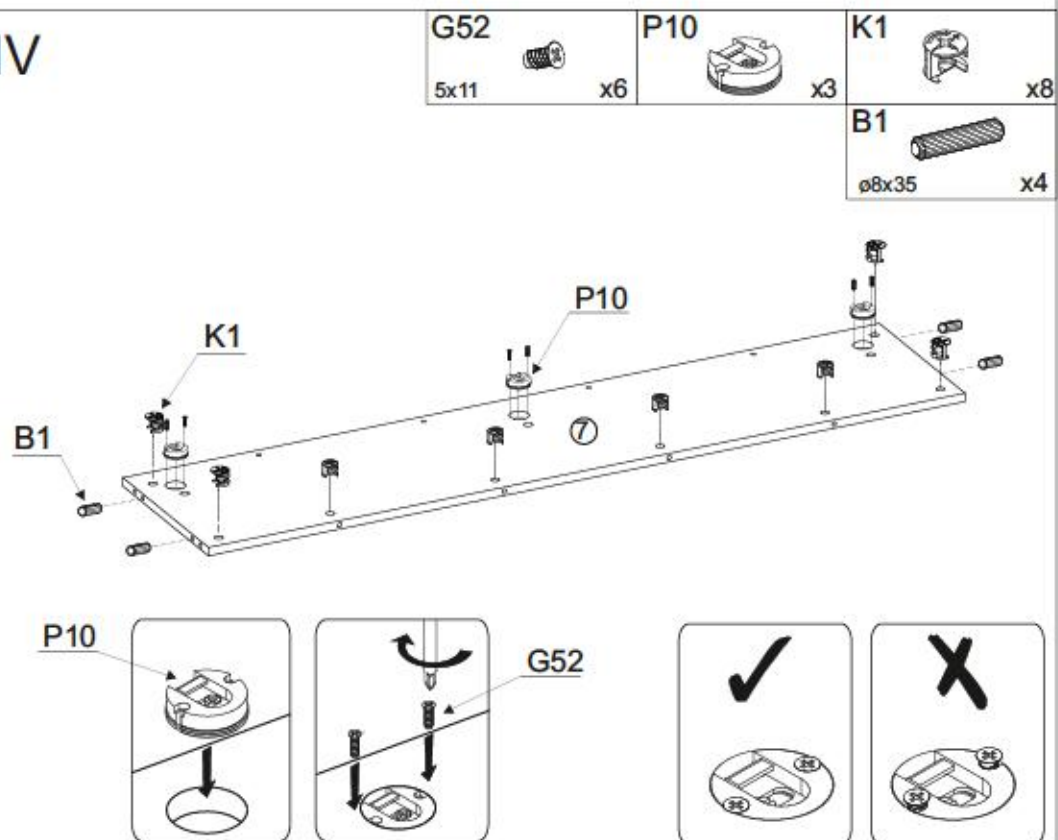



V

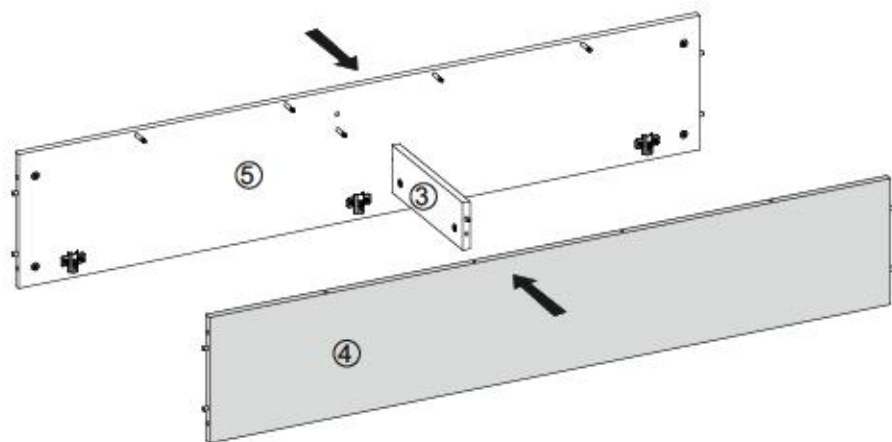
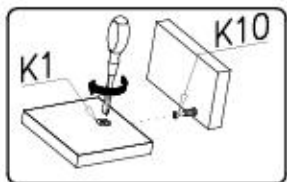

VI

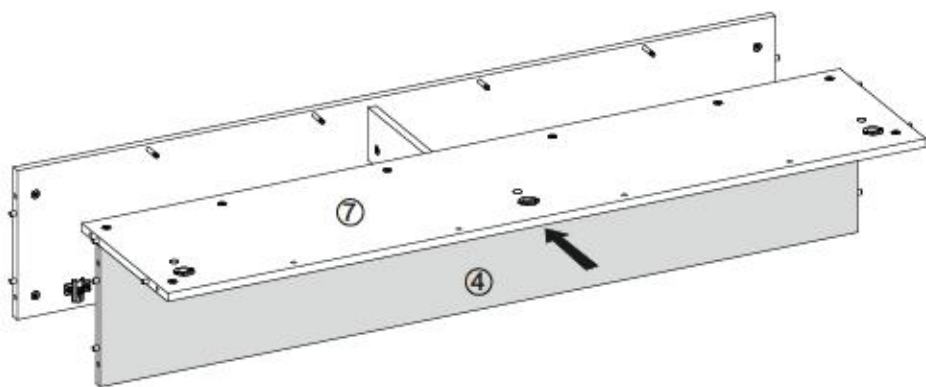
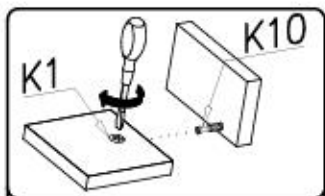

VII

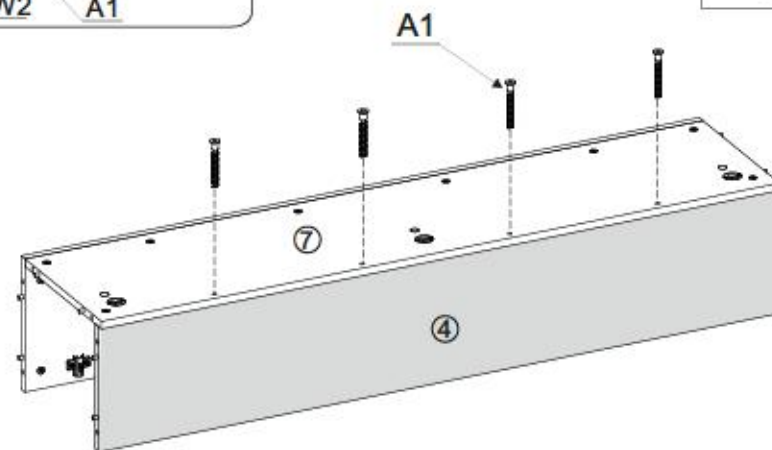
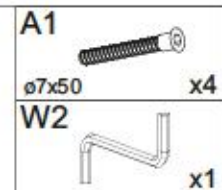
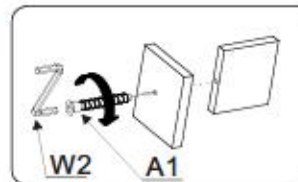

VIII

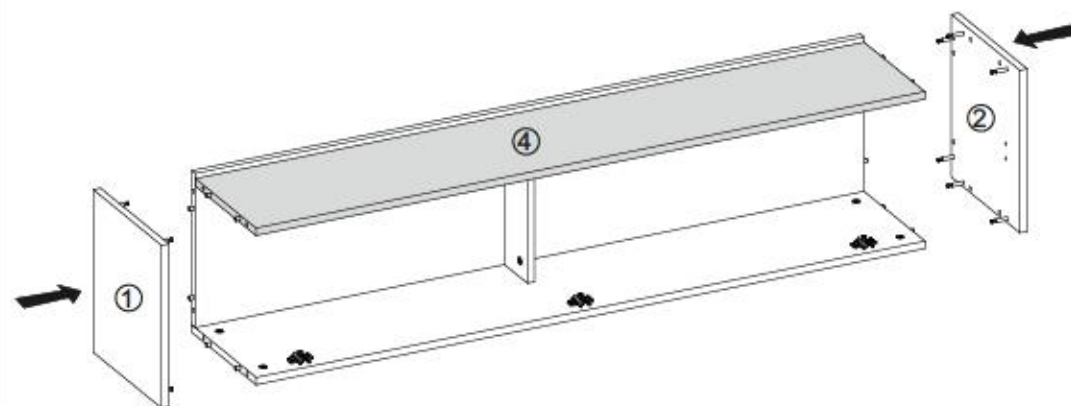
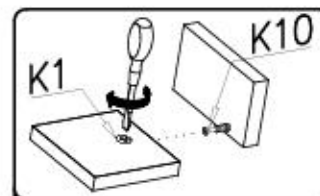



IX

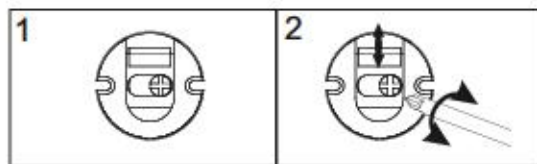
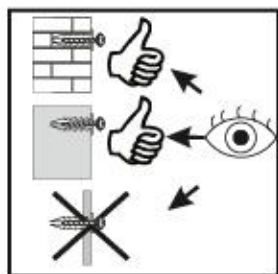
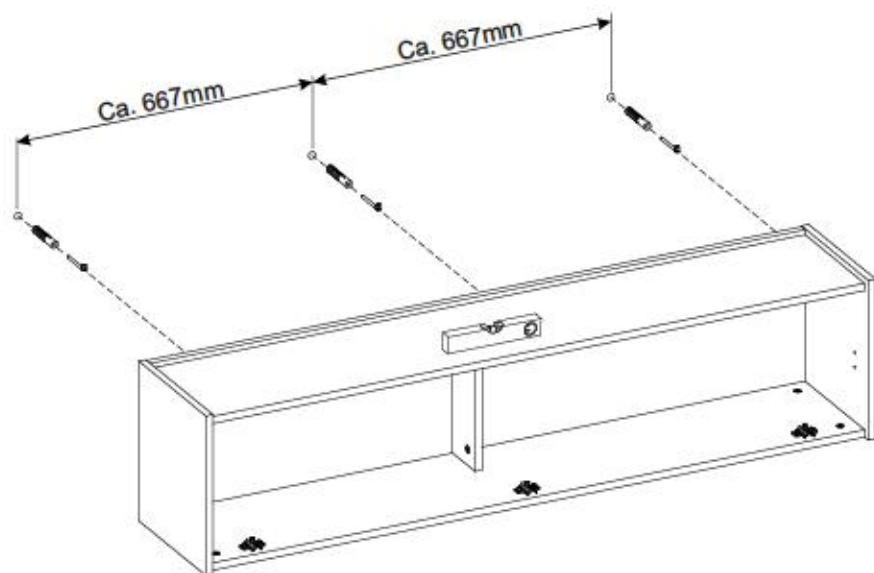

X

Q2
 x3

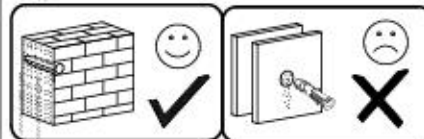
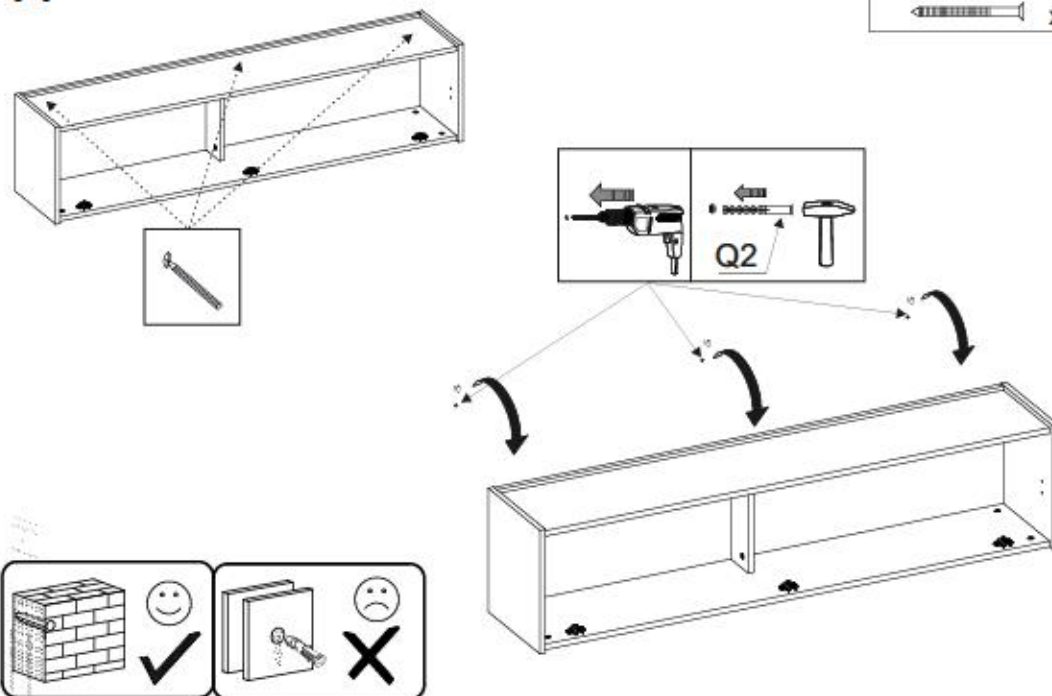

XI

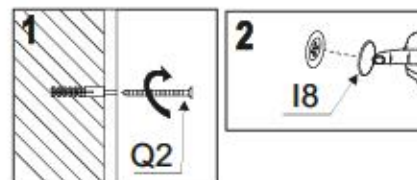

I8
 x6

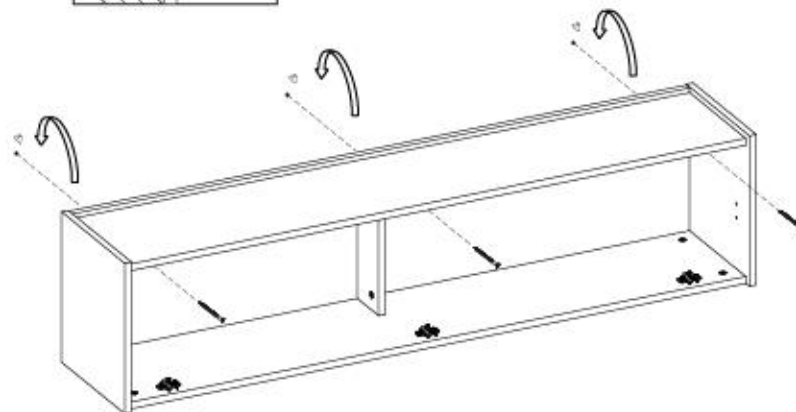

10/13

CITY / GIRON 46



XII

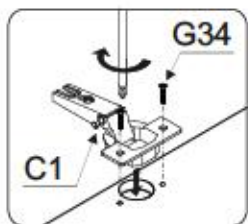

C1



x3

G34



3,5x16

x6

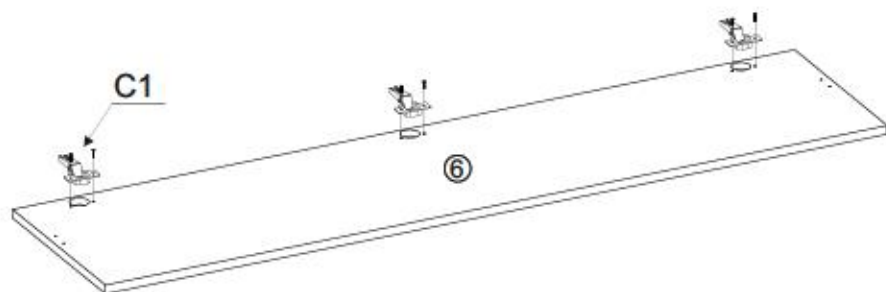

XIII

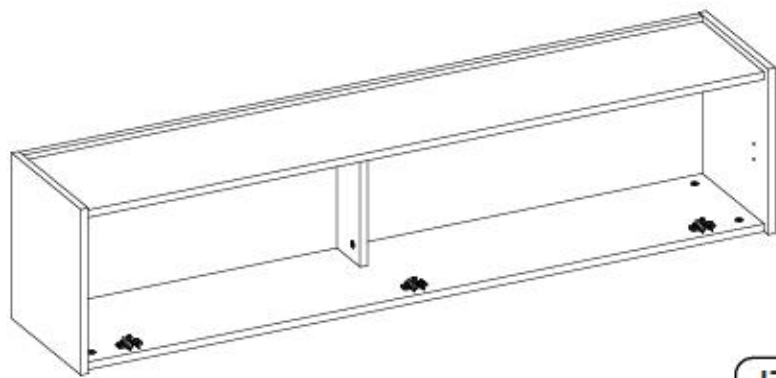

17



11/13

CITY / GIRON 46

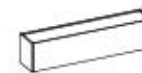

XIV

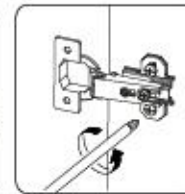
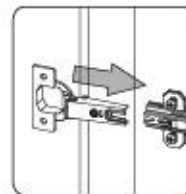

C10



x2

G34



3,5x16

x12

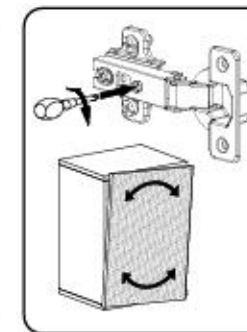
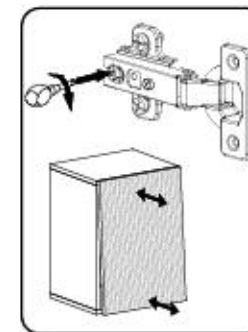
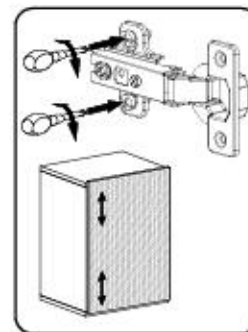
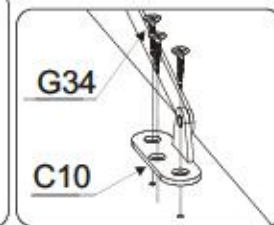
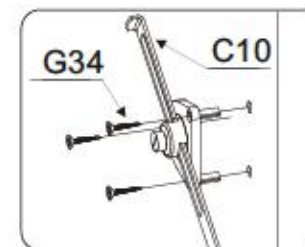
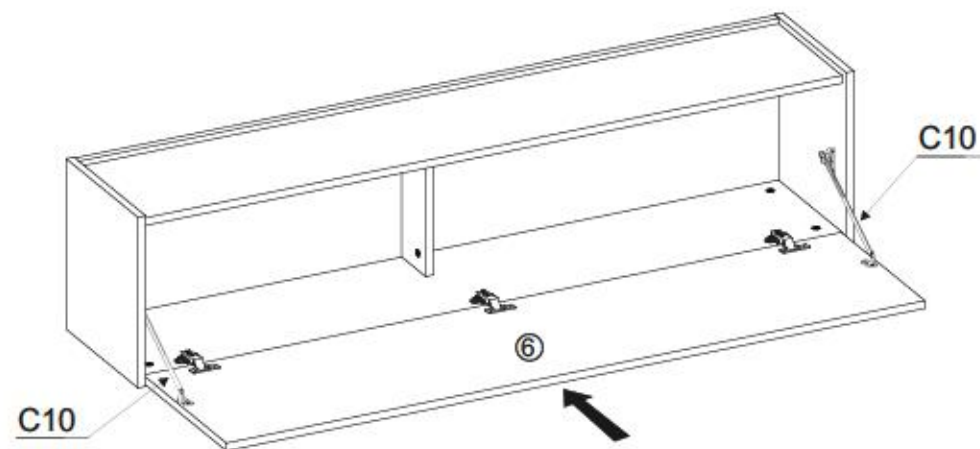

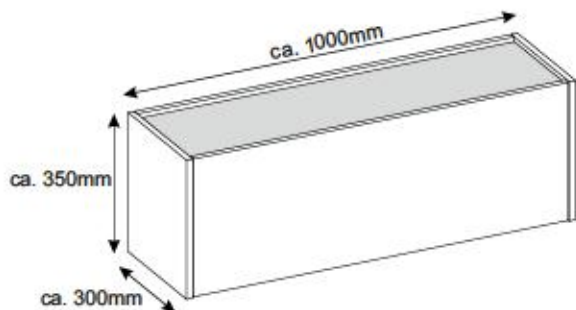

- Ⓛ Montageanleitung
- Ⓝ Handleiding voor de montage
- Ⓜ Montaj talimat
- ⓕ Notice de montage
- Ⓒ Montážní návod
- ⓗ Szerelési útmutató
- ⓖ Assembly Instructions
- Ⓟ Instrukcja montażu
- Ⓡ Инструкции по монтажу
- Ⓡ Istruzioni di montaggio
- Ⓢ Návod na montáž
- Ⓡ Instrucțiuni de montaj
- ⓔ Instrucciones de montaje
- Ⓡ Montaj Talimat

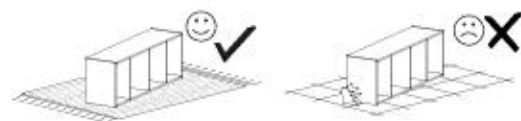
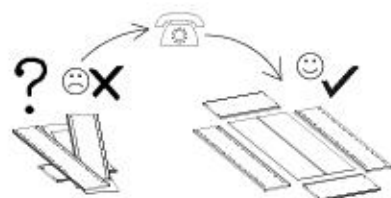
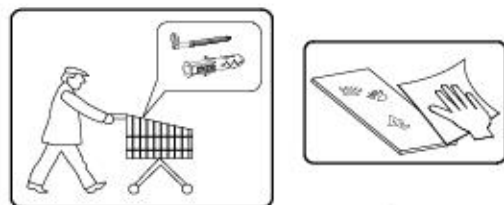
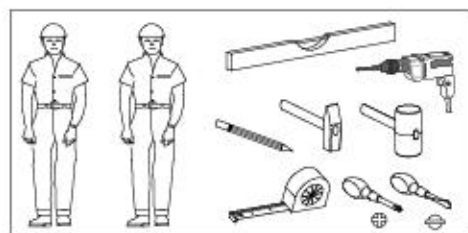

nr	L[mm]	B[mm]	T[mm]	Menge	Dati
1	350	300	16	1	1/1
2	350	300	16	1	1/1
3	968	266	16	1	1/1
4	968	283	16	1	1/1
5	968	332	16	1	1/1
6	962	347	16	1	1/1

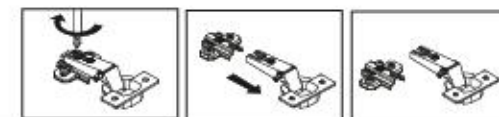
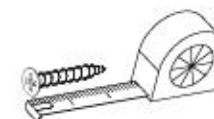
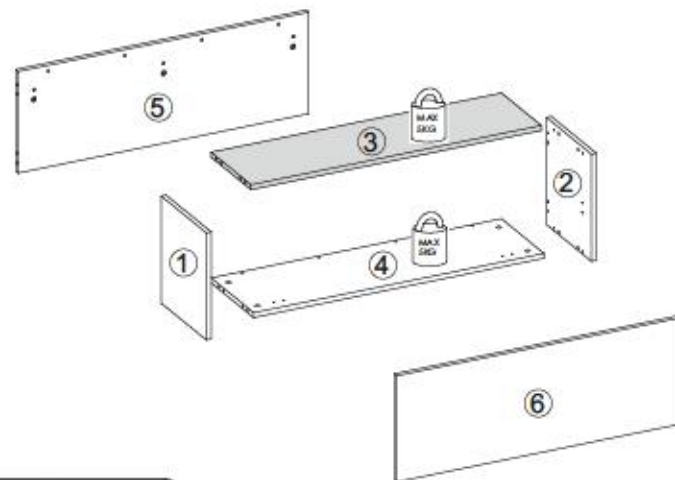

B1 ø8x35 x12	A1 ø7x50 x4	W2 x1	I7a x4	I7b x4
K1 x16	K10 x16	D4 x2	C1 x2	G34 3,5x16 x16
G52 5x11 x6	P10 x3	C10 x2	I8 x3	Q2 x3

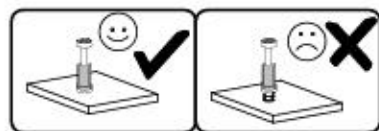
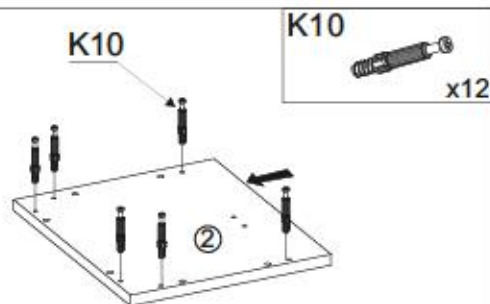
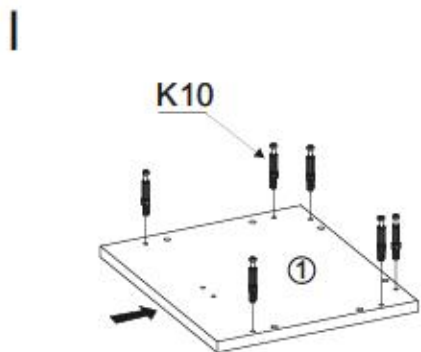

II

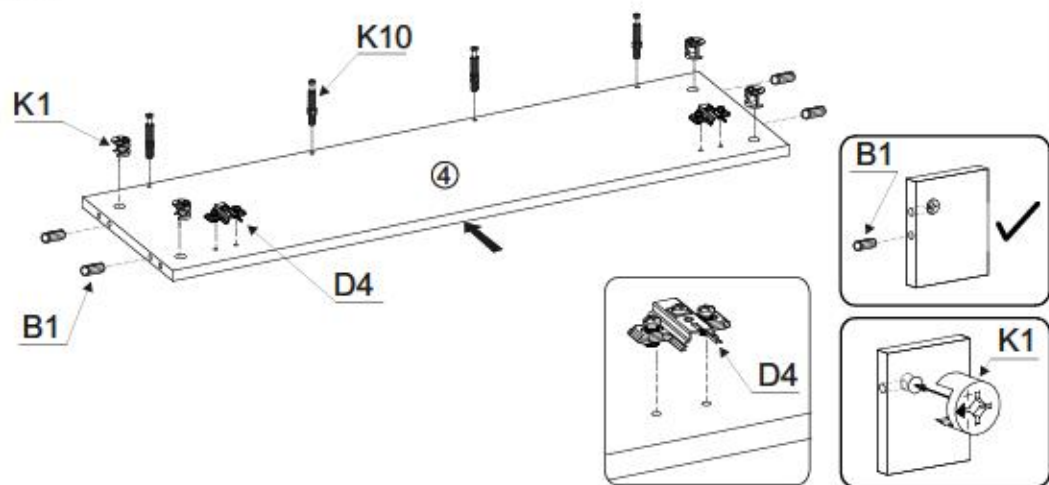
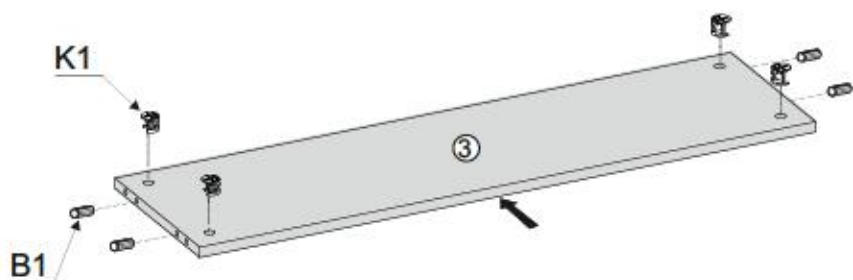

III

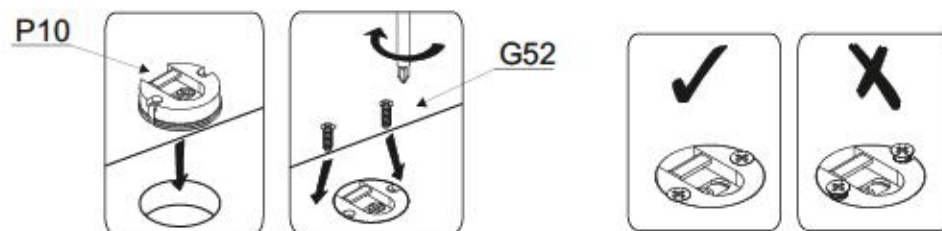
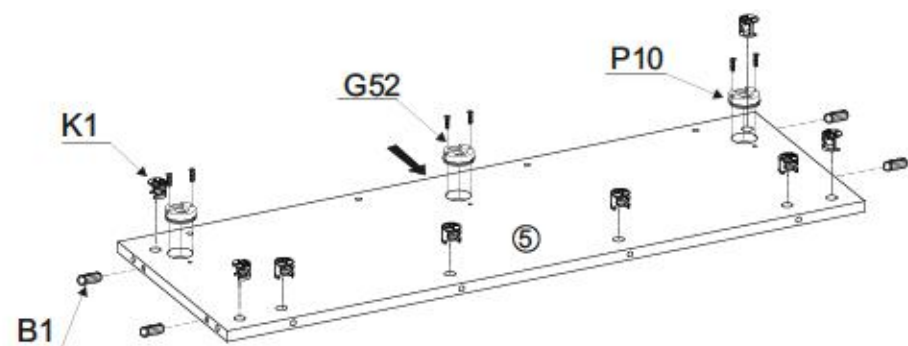
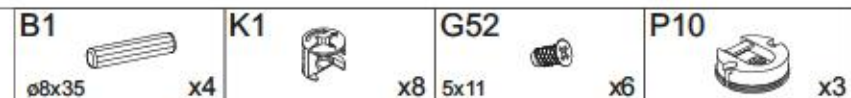

IV

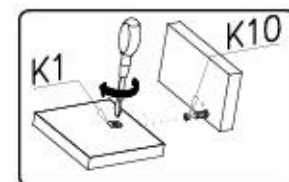
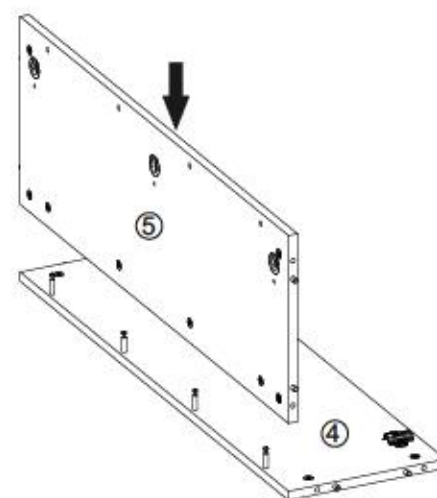



V

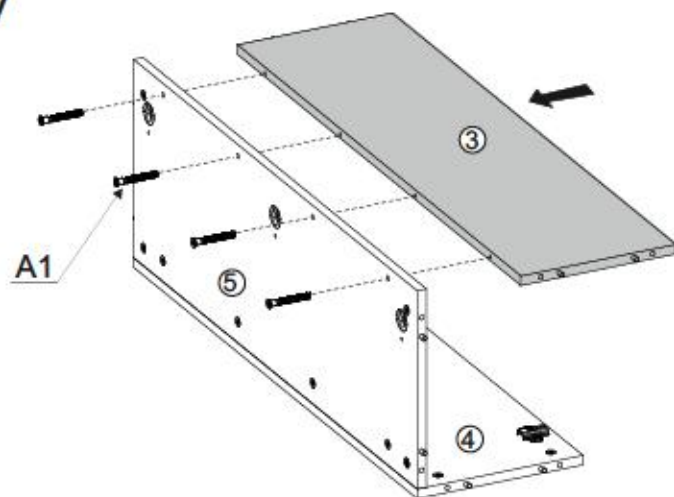

A1



ø7x50

x4

W2



x1

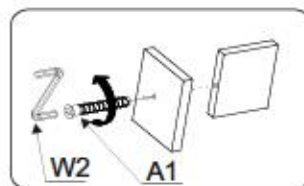

VI

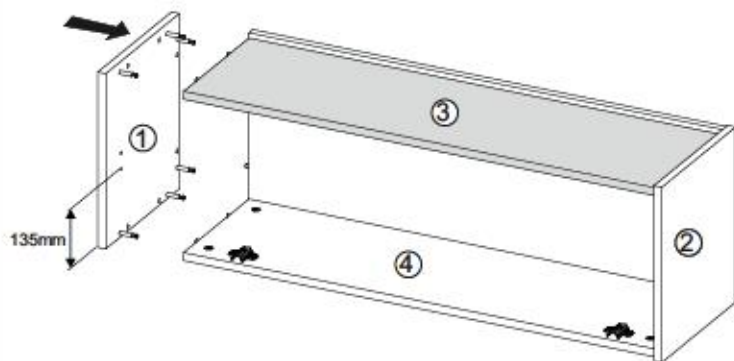
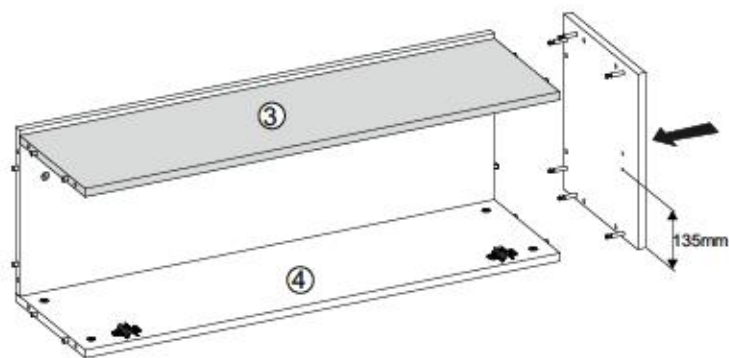

K1



K10



VII

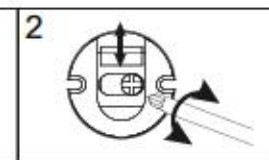
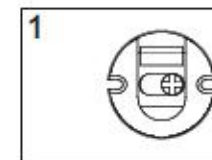
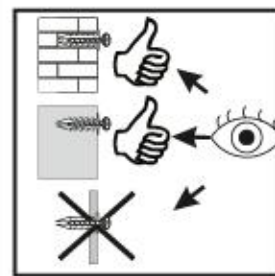
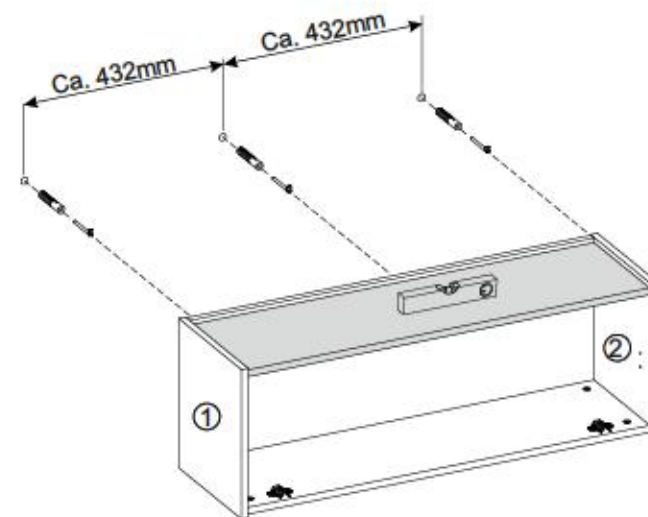
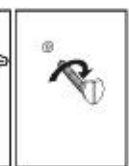
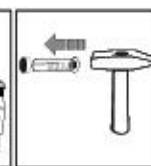
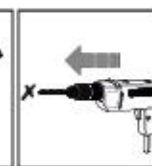
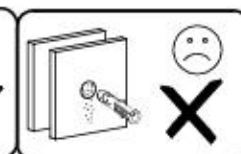
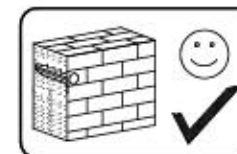

7/11

CITY / GIRON 47



VIII

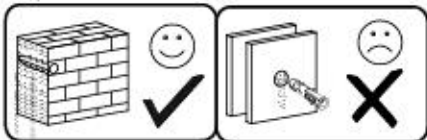
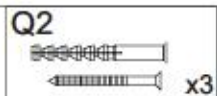
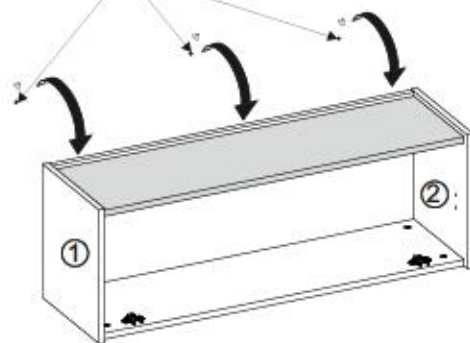
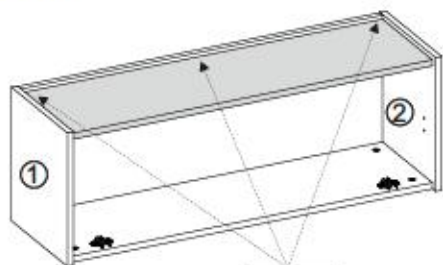

IX

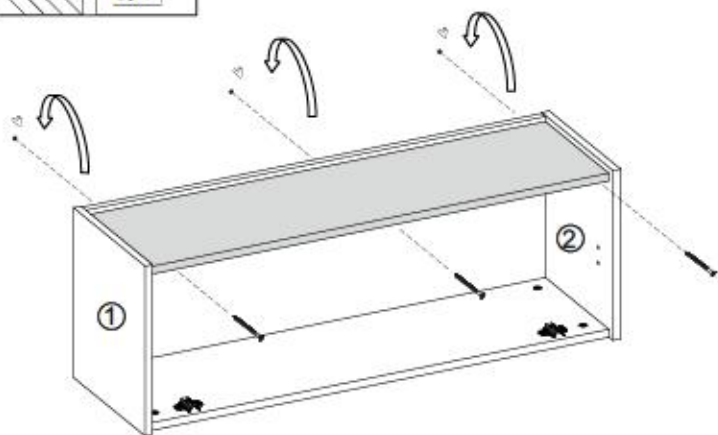
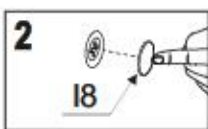
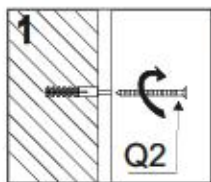

8/11

CITY / GIRON 47



X

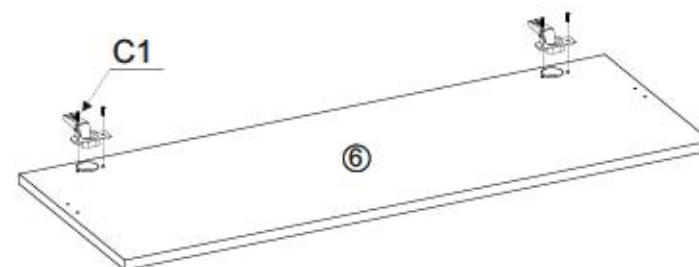
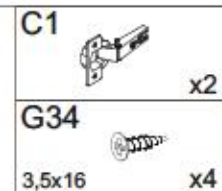
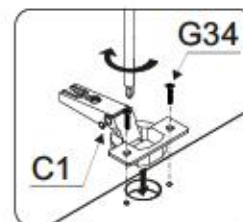

XI

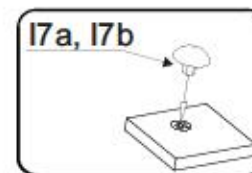
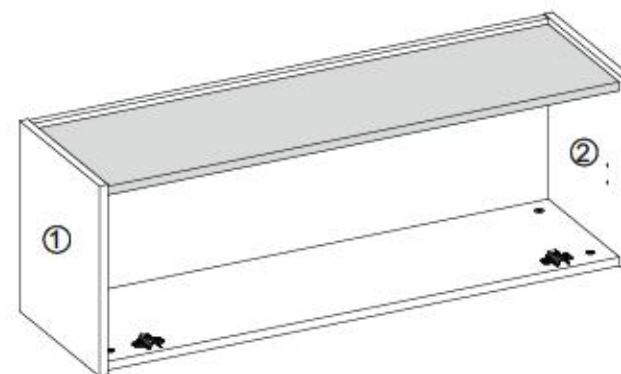
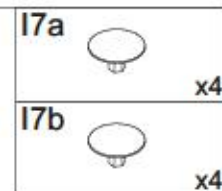



XII

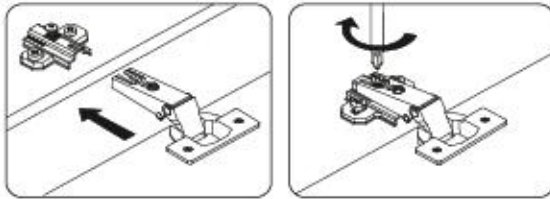

- C10 x2
- G34 x12
- 3,5x16

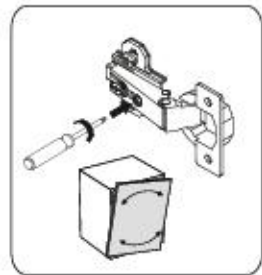
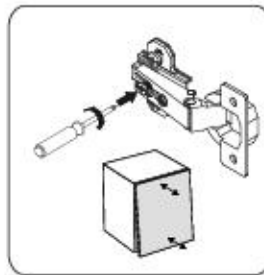
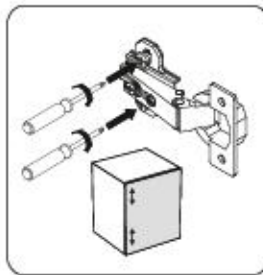
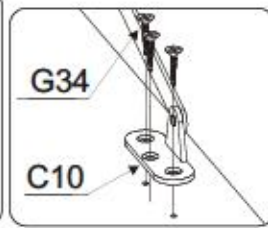
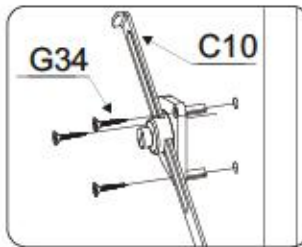
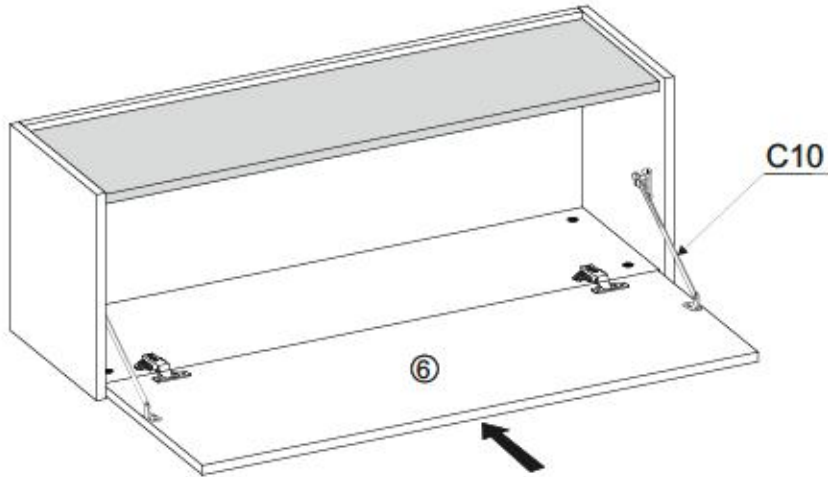

Name • Nom • Nome • Naam • Nazwa • Jméno • Νόζον • Νέυ • Denumire • Isim • Название	Nr • No • N° • Номер • Č • Sz	Typ • Type • Tip • Típus • Тíро • Tun
CITY / GIRON	--	47

D **Ukazanie Dostavateľa:** Príjemca zásielky
Sollte Ihnen ein Beschlagteil fehlen, können Sie diese Servicekarte direkt an die untenstehende Adresse mailen. Wir können allerdings nur Beschlagteile auf diesem Wege verschicken. Sollten Sie eine andere Bausendung an Ihrem Möbelstück haben, so wenden Sie sich bitte direkt an Ihr Möbelhaus.

GB Our direct order service for filling
If a fitting part is missing, you can e-mail this service card directly to the address below. However, we can only send fitting parts in this way. If you have any other issues for complete assembling your item of furniture, please contact your furniture store directly.

CZ **Nápis přílohy služby pro kování:**
Chybí-li vám nějaký díl z levnic, můžete tuto servisní kartu odeslat e-mailem přímo na níže uvedenou adresu. Touto cestou však můžeme to send at jen díly kování. Pokud byste měli nějaký jiný problém, obraťte se přímo na svého prodejce nábytku.

F **Bien étudier la notice de montage:**
Si vous remarque une erreur, veuillez envoyer directement la présente carte service à l'adresse e-mail indiquée ci-dessous. Cependant, ceci nous permet uniquement d'envoyer des serrures. Pour tout autre type de réclamation concernant votre meuble, veuillez contacter directement votre magasin d'ameublement.

I **Il nostro servizio diretto per i carti di della lavorazione:**
Qualora Vi dovesse mancare un pezzo di fissaggio, allora Vi preghiamo di inviare questa carta di servizio immediatamente all'indirizzo sottostante. Possiamo inviare i pezzi di fissaggio solamente per mezzo di questo procedimento. Qualora dovesse avere qualche altro problema relativo al mobile, allora Vi preghiamo di rivolgerVi direttamente al Vostro Negozio di mobili.

BG **Нашата директна услуга за обвив:**
Ако липовата част от комплектта, по която настъпва повреда, липовата част или липовата част на e-mail адреса, по която липовата част. Тя може да бъде получена по доставката. Ако имате друг проблем, свържете се директно с магазина, от който сте закупили стоката.

NL **Om direct service voor losse onderdelen:**
Wanneer er een onderdeel ontbreekt, kunt u deze servicekaart direct aan onze afdeling e-mailen. Wij kunnen langere dan weg schiel al een beschlagdeel vastzetten. Mocht u een ander probleem met een meubel hebben, verzaken wij u contact op te nemen met uw meubeldealer.

PL **Nasz bezpośredni serwis części montażowych:**
Jeżeli brakuje części montażowych do montażu, prosimy o przesłanie nam niżej podanej karty serwisowej na adres poczty elektronicznej. W ten sposób możemy przesłać: Połączenia tylko brzozygoc części. W przypadku innych reklamacji dotyczących mebla, prosimy o kontakt z naszymi sprzedawcami, w których został dokonany zakup.

HR **Služba za okovne:**
U slučaju da nedostaje neki od dijelova molimo vas da se dođe u veštavanje mail adresom polježe na ovaj broj. Na ovaj način mogu se dostaviti samo okovi. U slučaju da imate dodatne prigovore vezane uz lošad namještaja molimo vas da se obratite bravno trgovini namještaja gdje je isti kupljen.

HU **Direktrendelgetársunk varhatókat esetén:**
Ha hiányzik egy varható, azt a körlevél kitöltésénél elküldhet az alábbi táblázat címre. Azonban csakis varhatókat tudunk így küldeni. Amennyiben másféle reklamációt kívánunk bejelenteni, kérem, forduljon közvetlenül a boltjához.

SK **Náš priamy servis pre čisti kovania:**
Ak by Vám chýbala nejaká časť kování, môžete poslať túto servisnú kartu poslať e-mailom na nižšie uvedenú adresu. Cieľom kování v tomto postupe je iba kování. Ak by ste mali iný problém s kování nábytku, obráťte sa priamo na Vašu predajňu nábytku.

SLO **Náša direktna usluga za okovne:**
Če vam manjka kakikoli delov, lahko to sporo leto postelje po e-pošti direktno na spodnji naslov. Po tej poti vam lahko pošljemo samo okovne. Če imate kakikoli drugi problem s pohištva, se obrnite neposredno na vašo trgovino pohištva.

RO **Service-ul nostru direct pentru accesorii:**
In cazul în care vă lipsește o piesă de accesorii, puteți să trimiteți direct acest card de serviu prin e-mail la adresa de mai jos. Noi nu putem expedia piesa de la comenzi decât pe această cale. Dacă aveți o altă reclamație referitoare la piesa de mobilă, atunci vă rugăm să vă adresați direct la magazinul dvs. de mobilă.

RUS **Наш прямой сервис для поставки фурнитуры:**
Если окажется, что Вам не хватает того или иного элемента фурнитуры, Вы можете отправить сервисную карту по адресу непосредственно на электронную почту: Адрес электронной почты. Однако, таким образом мы можем переписать лишь фурнитуру. Если же у Вас возникнут иные проблемы относительно сборки мебели, пожалуйста, обращайтесь непосредственно в магазин, осуществляющий продажу.

S **Vår direkte tjena för beslagdelar:**
Om du saknar en beslagdel kan du skicka detta servicekort direkt till e-postadressen som anges nedan. Tänk på att detta är den enda möjligheten att skicka beslagdelar till dig. Om du vill reklamera din möbel av annan anledning än att du saknar ett beslagdel, direkt.

ES **Nuestro servicio directo para accesorios:**
Si le falta algún accesorio, puede enviar esta tarjeta de servicio directamente a la siguiente dirección. No obstante, por esta vía solo podemos enviar accesorios. Si tiene alguna otra objeción sobre su mueble, consulte directamente con su mueblería.

TR **Direktler için doğrudan teslimat:**
Bir donanım eksikliği veya bir donanım parçası bulunamıyorsa, adresle doğrudan mail ile yazabilirsiniz. Ancak bu yolla donanım alınamazdır. Mobilyanızda başka bir sorunuza varsa, lütfen doğrudan mobilya satıcınıza danışın.

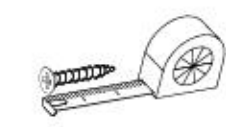

B1 x...	A1 x...	W2 x...
ø8x35	ø7x50	
I7a x...	I7b x...	K1 x...
K10 x...	D4 x...	C1 x...
G34 x...	G52 x...	P10 x...
3,5x16	5x11	
C12 x...	I8 x...	Q2 x...



+49 5233 95 290 10

service@mv-steinheim.de

Name • Nom • Nome • Naom • Nazwa • Имяно • Νόζον • Νέυ • Denumire • Isim • Имяние	Nr • No • N° • Номер • Č • Sz	Typ • Type • Tip • Трpus • Тipo • Tun
CITY / GIRON	---	47

D Unsere Dienstleistungen für Deutschland:
Sollten Ihnen ein Beschädigt sein, können Sie diese Servicekarte direkt an die untenstehende Adresse mailen. Wir können sie mit nur nur Beschädigt auf diesem Wege verschicken. Sollten Sie eine andere Beschreibung an Ihren Möbelstück haben, so wenden Sie sich bitte direkt an Ihr Möbelhaus.

GB Our direct order service for fitting:
If a fitting part is missing, you can e-mail this service card directly to the address below. However, we can only send fitting parts in this way if you have any other cause for complaint concerning your item of furniture, please contact your furniture store directly.

CZ Náš přímý službu pro kování:
Chytl-li vám nějaký díl z kování, můžete tuto servisní kartu odeslat e-mailem přímo na níže uvedenou adresu. Touto cestou však můžeme poslat jen díly kování. Pokud byste měli nějakou jinou důvod reklamace, obraťte se přímo na svého prodejce nábytku.

F En attendant la notice de montage:
Si vous remarquez une erreur, veuillez envoyer directement la présente carte service à l'adresse e-mail indiquée ci-dessous. Cependant, ceci nous permet uniquement d'envoyer des ferures. Pour tout autre type de réclamation ne concernant votre meuble, veuillez contacter directement votre magasin d'ameublement.

I Il nostro servizio di aiuto per il ordine dei feramenti:
Qualora vi dovesse mancare un pezzo di fissaggio, allora vi preghiamo di inviarci questa carta di servizio immediatamente affinché il pezzo venghi spedito. Possiamo inviare i pezzi di fissaggio solamente per mezzo di questo procedimento. Qualora dovete avere qualche altra reclamazione in merito al mobile, allora vi preghiamo di rivolgervi direttamente al Vostro Negozio di mobili.

BG Нашата директна услуга за обнова:
Ако ви липне част от комплекта, потържете местоположението на продавача на мебелите и не изпращайте ни е-мил адреса, пощенски по-поруки. По този начин можете да доставим само необходимите елементи от обнова. Ако установите друг дефект по мебелите, Ви съветваме да се обърнете към магазините за мебелировка, от който сте закупили мебелите.

NL Onze directservice voor losse onderdelen:
Wanneer er een onderdeel ontbreekt, kunt u deze servicekaart direct aan onderstaand e-mailadres sturen. Wij kunnen langzame deze weg echter alleen best geplaatte vastmaken. Mocht u een ander probleem aan uw meubel hebben, verzoeken wij u contact op te nemen met uw meubel dealer.

PL Nasz bezpośredni serwis części montażowych:
Jeżeli brakuje części konstrukcyjnych do montażu, prosimy o przesłanie nam niniejszej karty za pośrednictwem poniższej adresy e-mailowej. W ten sposób możemy przesyłać Państwu tylko brakujące części. W przypadku innych reklamacji dotyczących mebla, prosimy zgłaszać je do swojego meblowego, w którym został dokonany zakup.

HR Servis za otkov:
U slučaju da nedostaje neki od dijelova molimo vas da na dole navedenu mail adresu pošaljete naš servisni karticu. Na ovaj način mogu se dostaviti samo otkovi. U slučaju da imate dodatne prigovore vezane uz komad namještaja molimo vas da se obratite izravno trgovini namještaja gdje je isti kupljen.

HU Direktna gátlásunk vasalathoz érvelni:
Ha hiányzik egy vasalat, ezt a kártyát elektronikus úton küldhet el az alábbi e-mail címre. Azonban csak a vasalathoz szükséges alkatrészeket tudunk elküldeni. Amennyiben más kifogással rendelkezik a fém konstrukciójaival, forduljon kizárólag a bolti képviselőjéhez.

SK Náš priamy servis pre štít kování:
Ak by vám chýbala niekajá časť kování, môžete poslať túto servisnú kartu e-mailom na nižšie uvedenú adresu. Cieľ je kováni a vieme poslať iba tieto správkom. Ak by ste mali inú sťažnosť ohľadom Vášho nábytku, obráťte sa priamo na Vašu predajňu nábytku.

SLO Náš direktni uslužbeni strokovni za otkove:
V vašem meblu je kakšno otkovo, lahko to servisu karitko pošljete po e-pošti direktno na spodnji naslov. Po tej poti vam lahko pošljemo samo otkove. Če delite reklamacijo kakšnega drugega dela pohištva, se obrnite neposredno na vašo trgovino pohištva.

RO Serviciul nostru direct pentru kování:
În cazul în care vă lipsește o piesă de kování și nu puteți să trimiteți direct această card de service prin e-mail la adresa de e-mail jos. Nu în putem expedia piesa de feronerie decât pe această cale. Dacă aveți o altă reclamație și referitoare la piesa de mobilier, atunci vă rugăm să vă adresați direct la magazinul dvs. de mobilier.

RUS Наш прямой сервис для поставки фурнитуры:
Если обнаружено, что Вам не хватает того или иного элемента фурнитуры, Вы можете отправить сервисную карту по факсу непосредственно на неограниченный адрес электронной почты. Однако, такие образцы мы сможем переслать лишь напрямую. Если же у Вас возникнут любые претензии относительно конструктивной мебели, пожалуйста, обращайтесь непосредственно в магазин, осуществляющий продажу.

S Vår direktservice för bestagdelar:
Om du saknar en bestagdel kan du skicka detta servicekort till oss. Vi kan endast skicka bestagdelar på detta sätt. Om du har andra anmärkningar på ditt möbelsåg, kontakta direkt ditt möbelsåg.

ES Nuestro servicio directo para accesorios:
Si le falta algún accesorio, puede enviar esta tarjeta de servicio directamente a la siguiente dirección. No obstante, por este método solo podemos enviar accesorios. Si tiene alguna otra objeción sobre su mueble, consulte directamente con su mueblería.

TR Doğrudan hizmet için aksesuarlar:
Eğer donanılar eksikse bu servisi belirli donanımlar hakkında bir adresine doğrudan mail ile gönderebilirsiniz. Sadece bu yolla donanımları gönderebiliriz. Mobilyanızda başka şikayetler varsa lütfen doğrudan mobilya satıcınıza danışın.

nr	L [mm]	B [mm]	T [mm]	Menge	Coll
1	350	300	16	1	1/1
2	350	300	16	1	1/1
3	968	266	16	1	1/1
4	968	283	16	1	1/1
5	968	332	16	1	1/1
6	962	347	16	1	1/1

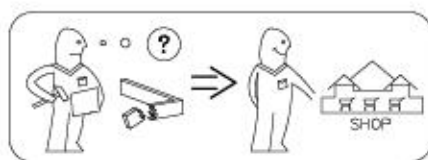
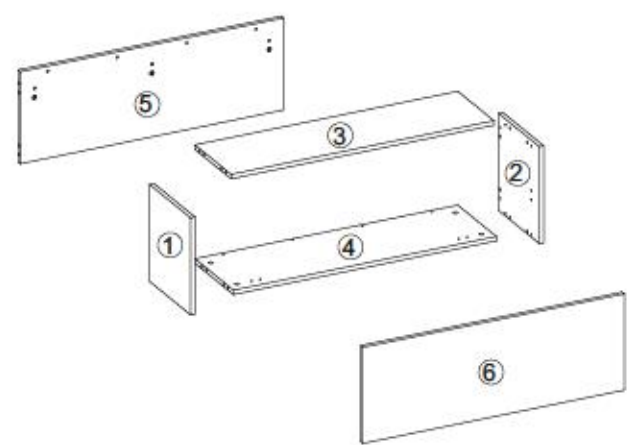

Modell: CITY / GIRON 56

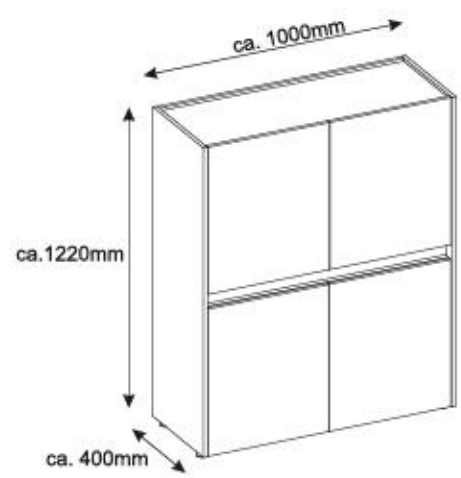

- D** Montageanleitung
- NL** Handleiding voor de montage
- TR** Montaj talimatı
- F** Notice de montage
- CZ** Montážní návod
- HU** Szerelési útmutató
- GB** Assembly Instructions
- PL** Instrukcja montażu
- RU** Инструкция по монтажу
- IT** Istruzioni di montaggio
- SK** Návod na montáž
- RO** Instrucțiuni de montaj
- ES** Instrucciones de montaje
- TR** Montaj Talimatı

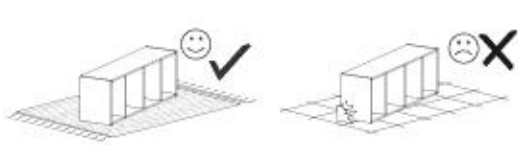
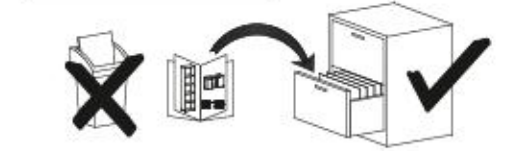
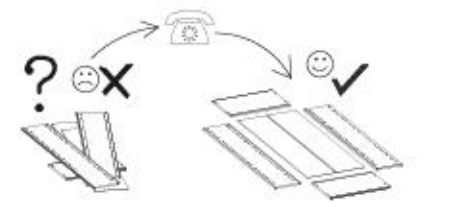
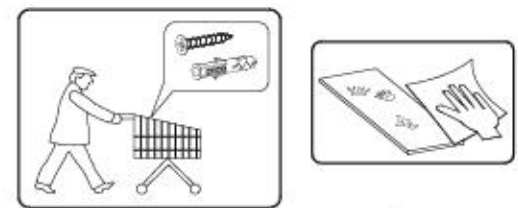
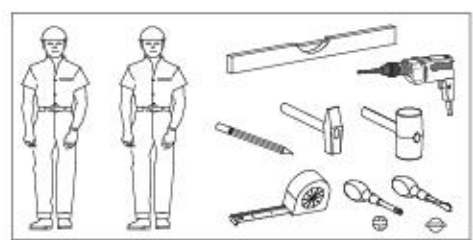

2,5h

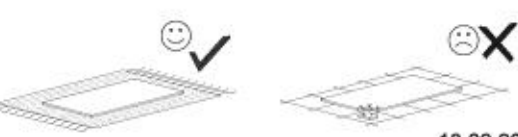



nr	L[mm]	B[mm]	T[mm]	Menge	Coll
1	1200	400	16	1	2/2
2	1155	323	16	1	2/2
3	1200	400	16	1	2/2
4	968	366	16	1	1/2
5	476	322	16	4	1/2
6	476	322	16	1	1/2
7	476	322	16	1	1/2
8	968	362	16	1	1/2
9	968	80	16	1	2/2
10	968	77	38	1	2/2
11	571	480	16	4	2/2
12	1170	489	3	1	2/2
13	1170	489	3	1	2/2

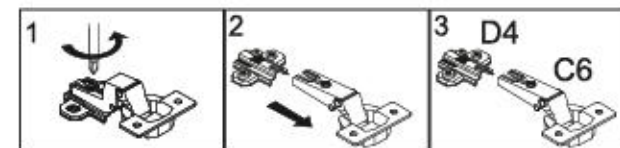
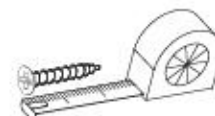
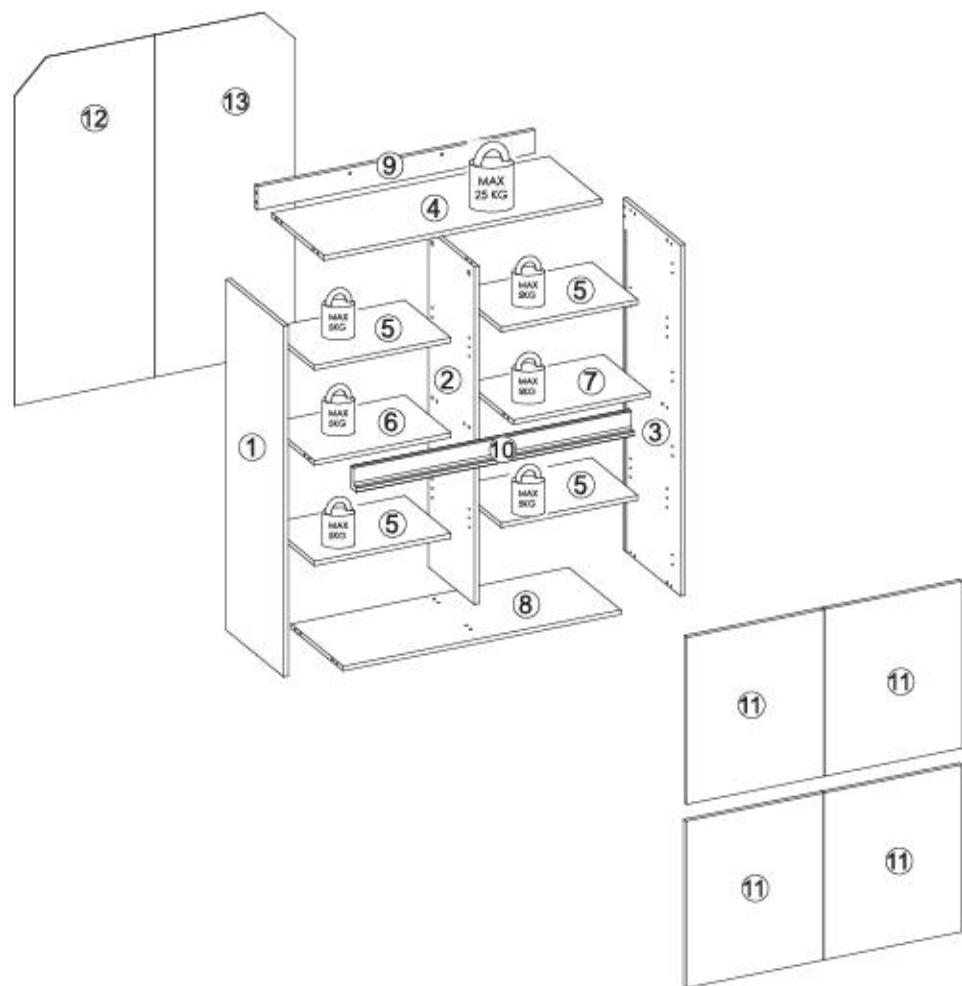

B1 ø8x35 x20	B3 ø8x60 x2	A1 ø7x50 x4	W2 x1	I7 x14
K1 x18	K10 x14	D4 x8	C6 x8	G34 3,5x16 x18
K12 x2	G49 4x16 x16	F13 x4	Z6 x8	I1 x6
F2 x16	M11 x2	G50 3x20 x20	P10 x5	G36 4x30 x5



I

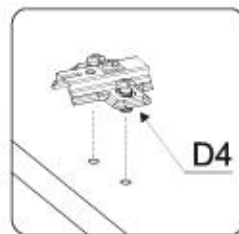
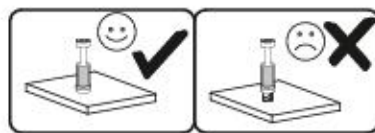
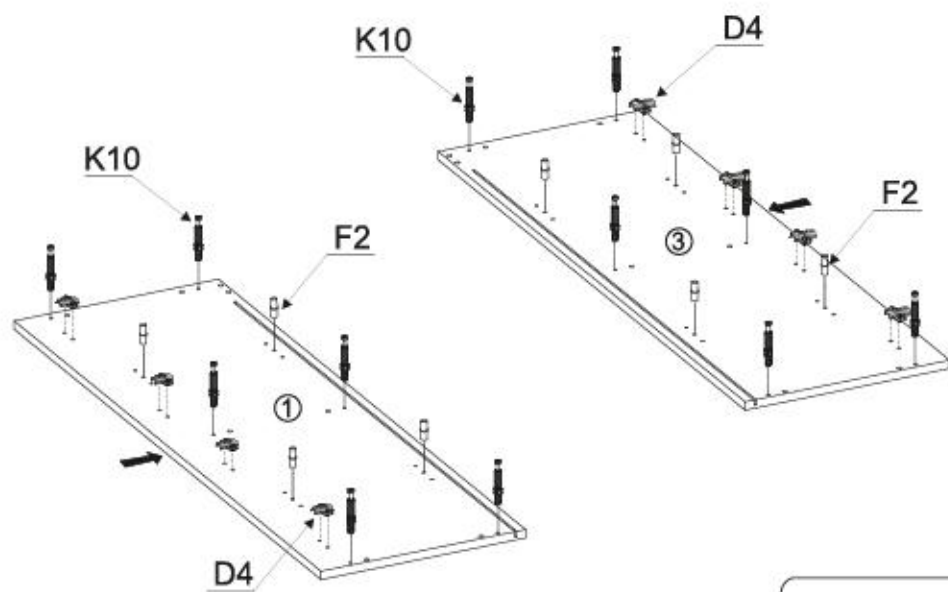
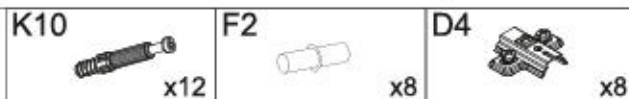

II

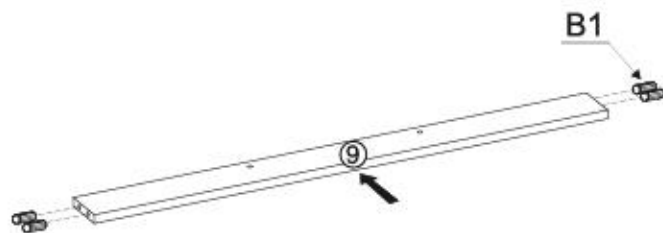
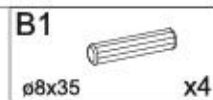

III

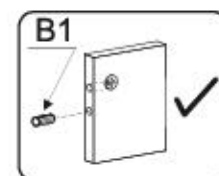
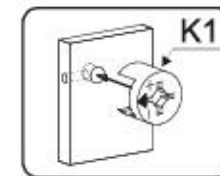
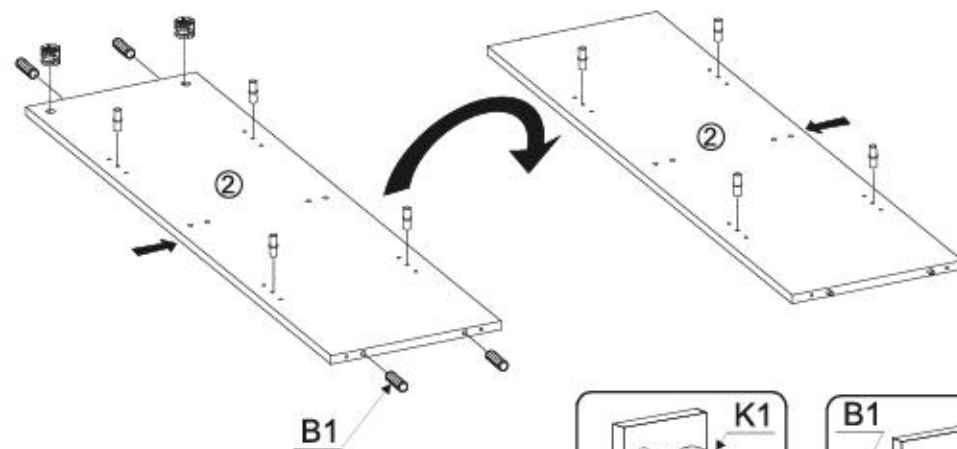
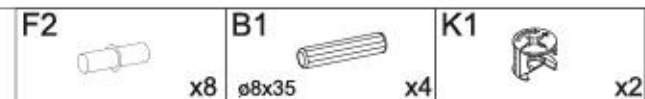

IV

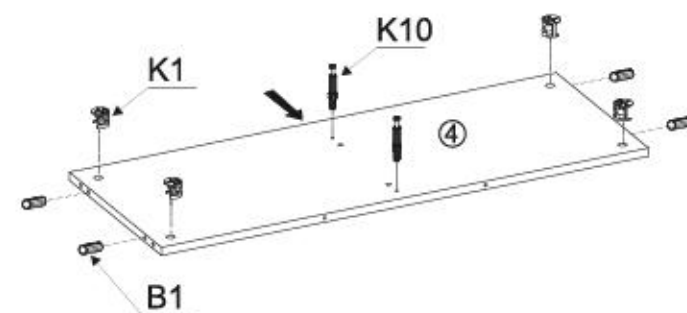
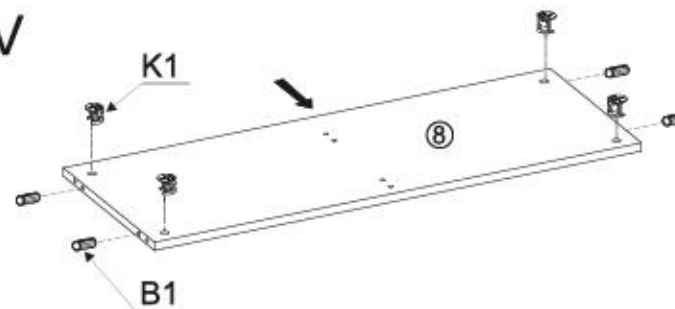
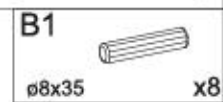



V

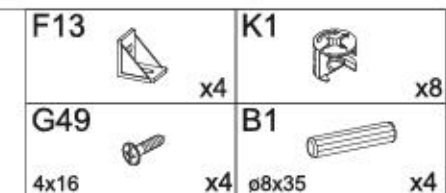
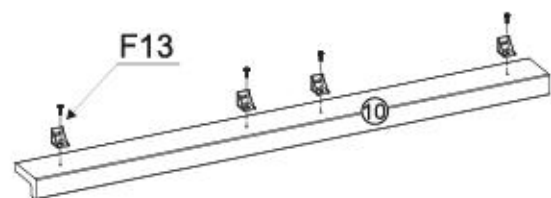
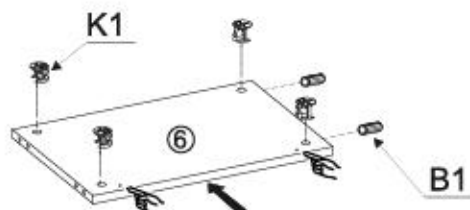
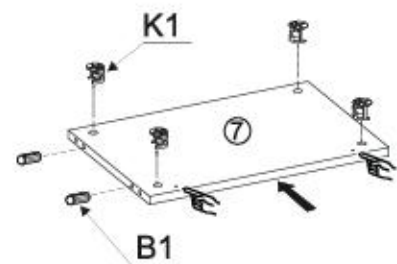

VI

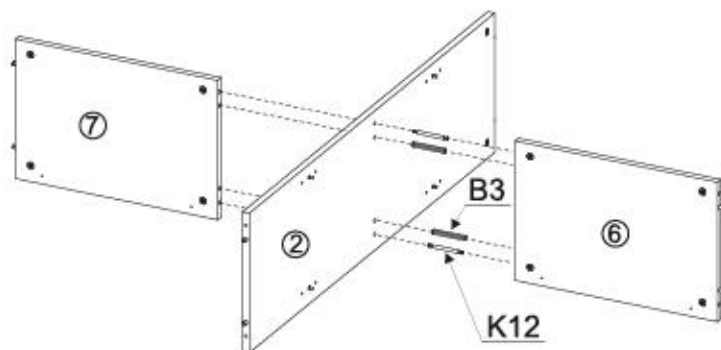
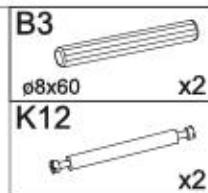
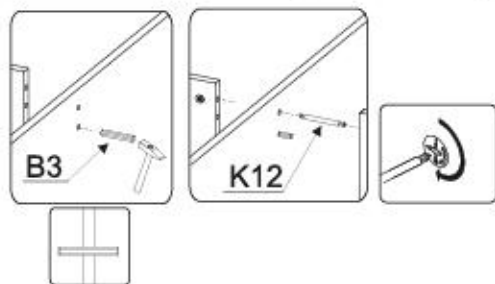

VII

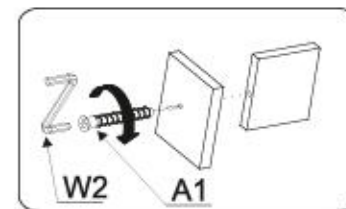
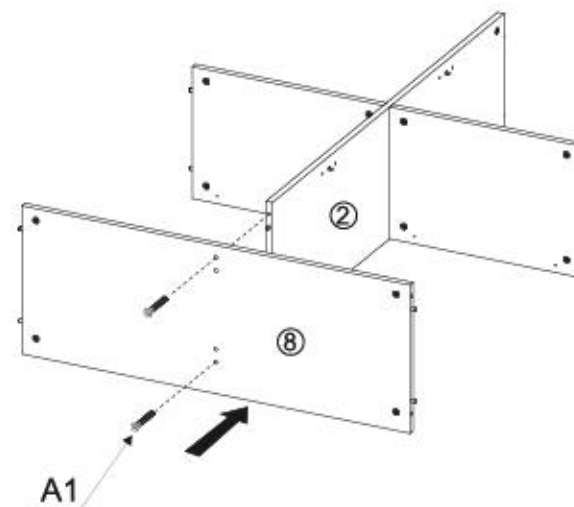

VIII

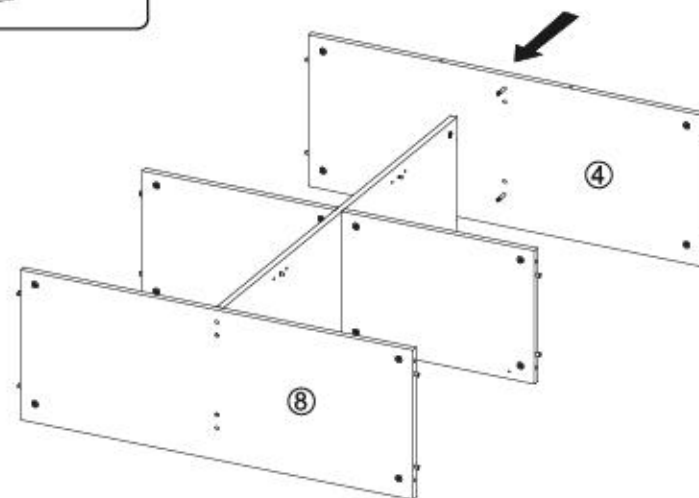
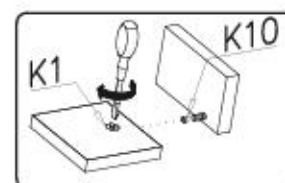



IX

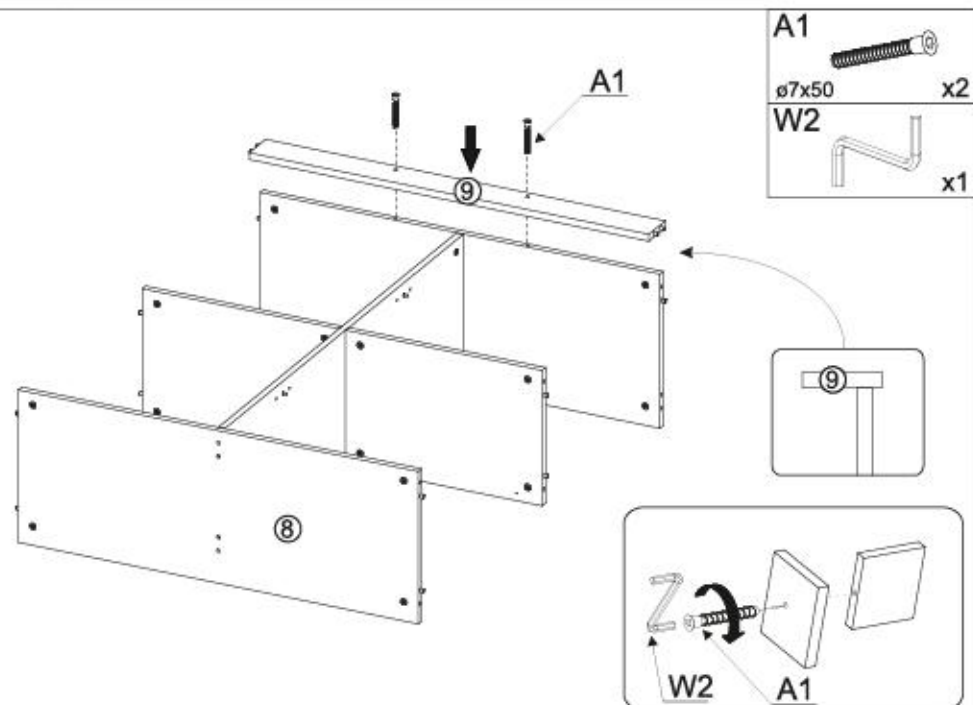

X

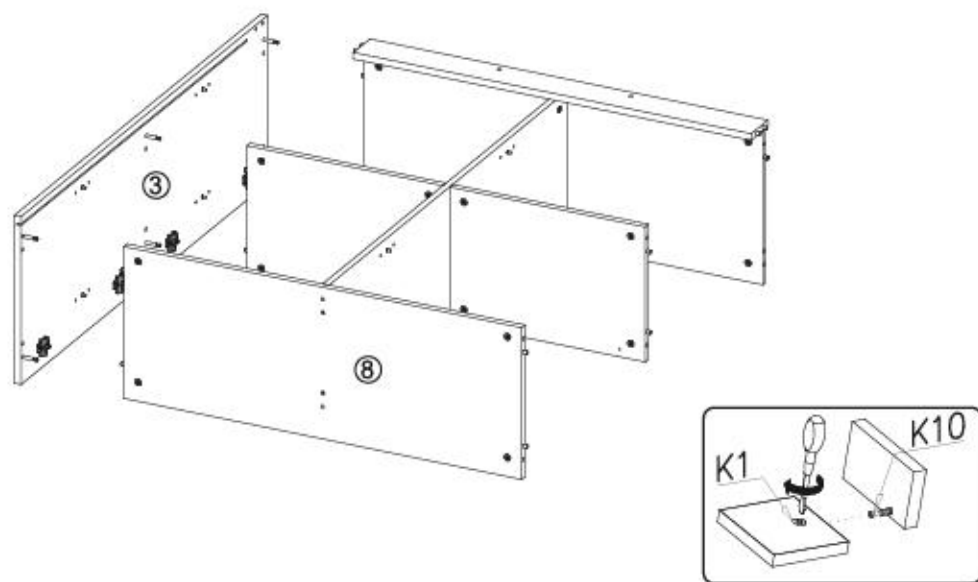

XI

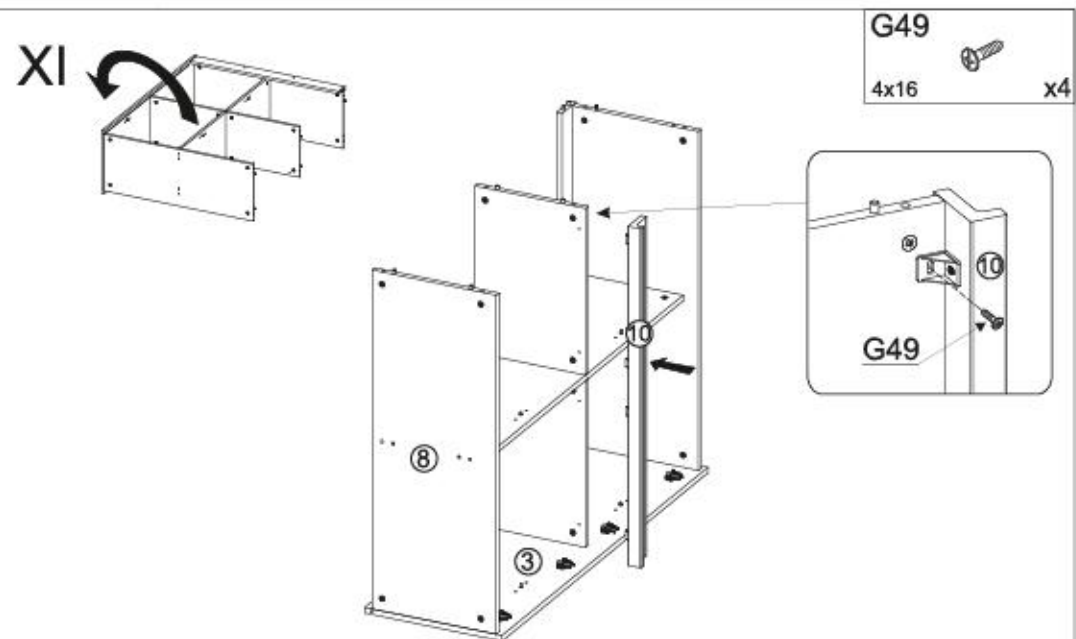

XII

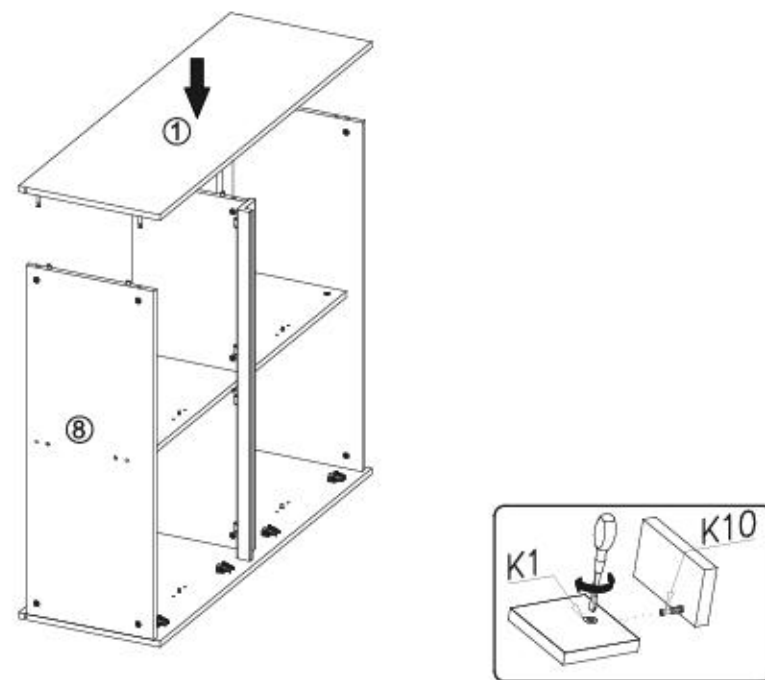



XIII

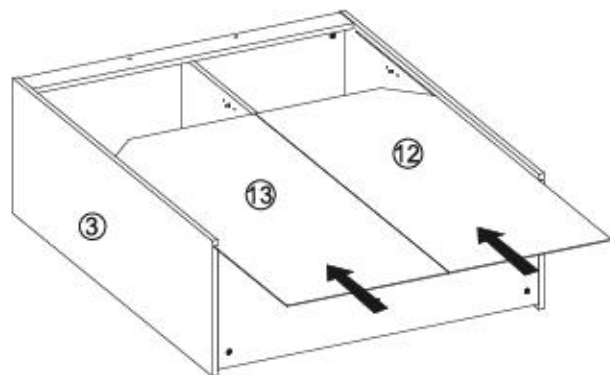

XIV

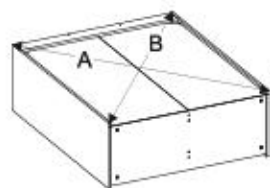

A=B

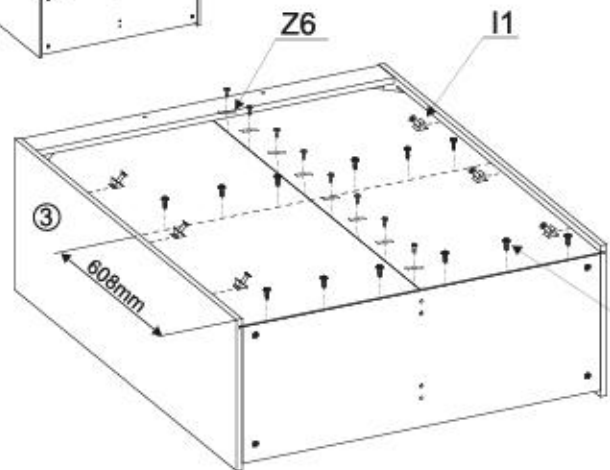

G50

3x20 x20

I1

x6

Z6

x8

G50

a=b

G50

a=b

I1

min.
100mm

G50

Z6



XV

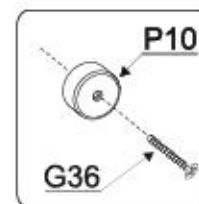

P10

x5

G36

4x30

x5

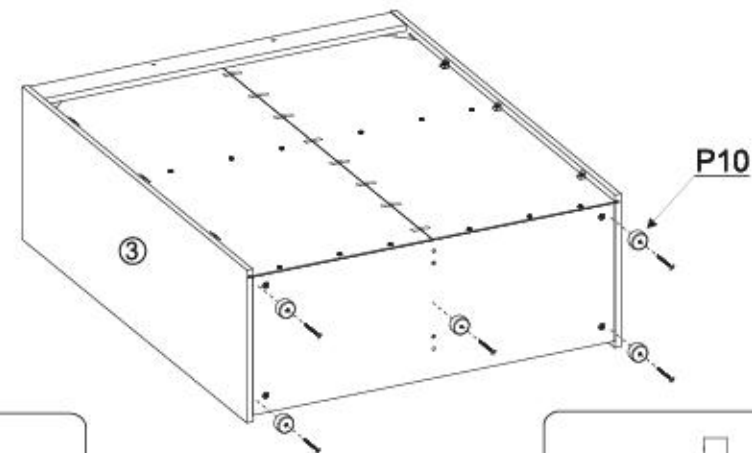

P10

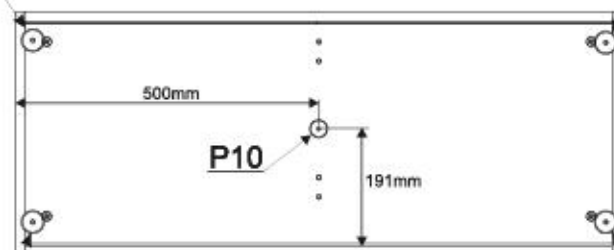
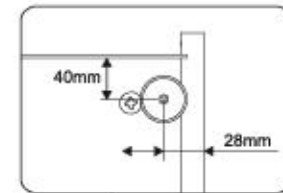
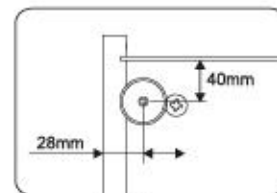

P10

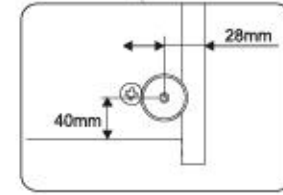
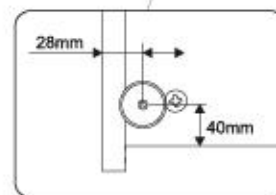



XVI

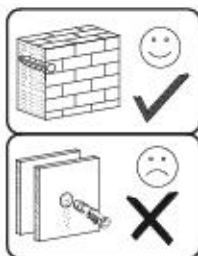

G34



3,5x16 x2

M11



x2

I7



x14

G49



4x16 x8

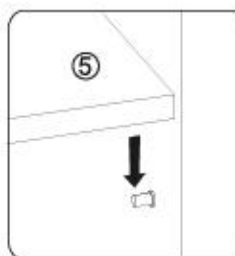
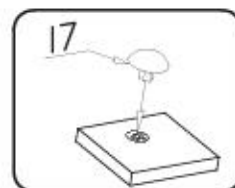
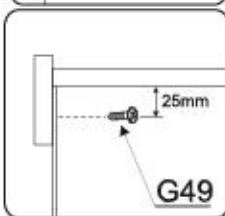
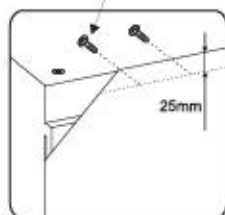
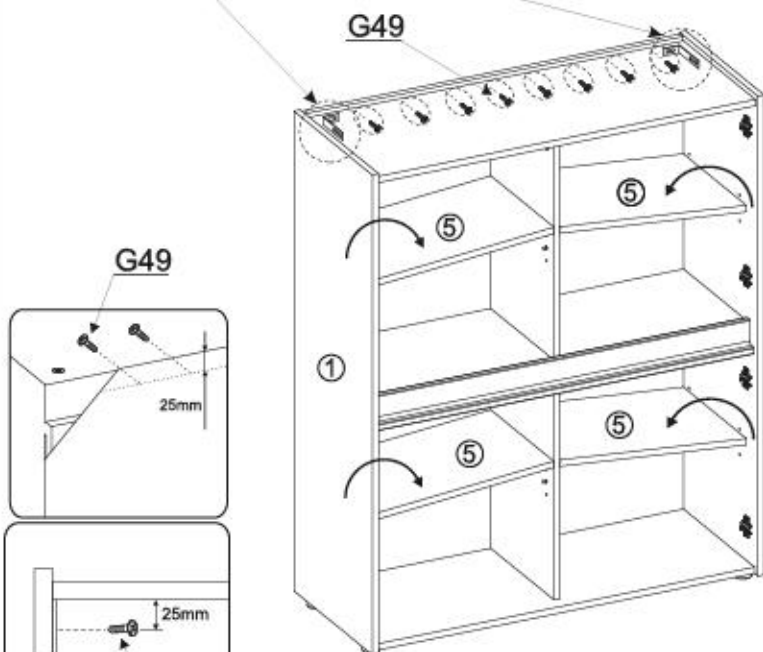
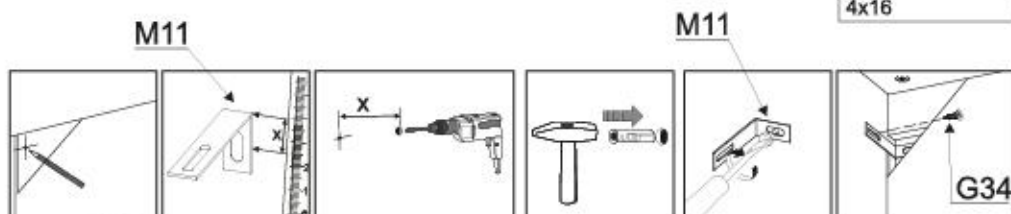

XVII

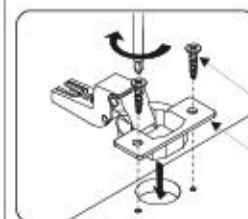

G34

C6

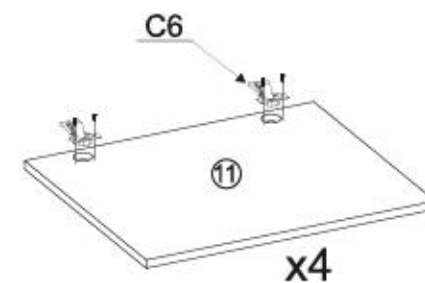

x4

C6



x8

G34



3,5x16 x16

XVIII

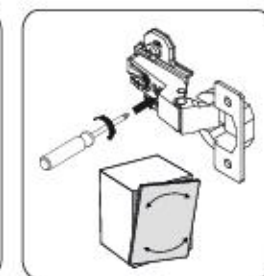
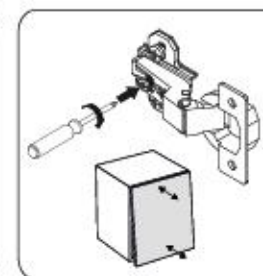
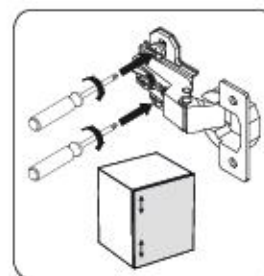
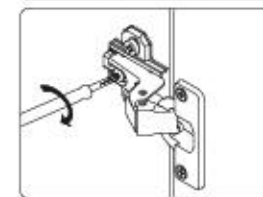
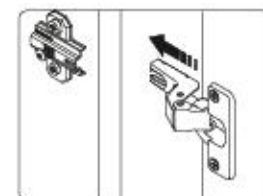
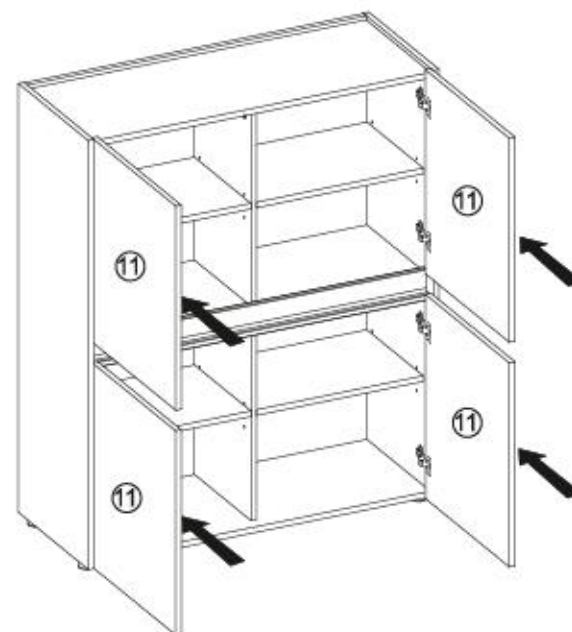

Name • Nom • Nome • Naam • Nazwa • Jméno
• Názov • Név • Denumire • İsim • Имя
CITY / GIRON --- 56

D Unser Dienstverleiher ist beschädigt
Solte Ihnen ein Beschädigter fallen, können Sie diese Servicekarte direkt an die untenstehende Adresse mailen. Wir können allerdings nur Beschädigte auf diesem Wege verschicken. Sollten Sie eine andere Beanstandung an Ihrem Möbelstück haben, so wenden Sie sich bitte direkt an Ihr Möbelhaus.

GB Our direct order service for filing
If a filing part is missing, you can e-mail this service card directly to the address below. However, we can only send filing parts in this way if you have any other cause for complaint concerning your item of furniture, please contact your furniture store directly.

CZ Naše přímá služba pro škody
Chytrá vám nějaký díl z kování, můžete tuto servisní kartu odeslat e-mailem přímo na níže uvedenou adresu. Touto cestou však můžeme rozeslat jen díly kování. Pokud byste reklamovali jiný díl nábytku, obraťte se přímo na svého prodejce nábytku.

F Rien acheter la notice de montage
Si vous manque une ferrure, veuillez envoyer directement la présente carte service à l'adresse e-mail indiquée ci-dessous. Cependant, ce nous permet uniquement d'envoyer des ferrures. Pour tout autre type de réclamation concernant votre meuble, veuillez contacter directement votre magasin d'aménagement.

I Il nostro servizio diretto per i ordini delle ferrature
Qualora Vi dovesse mancare un pezzo di ferratura, allora Vi preghiamo di inviare questa carta di servizio immediatamente all'indirizzo sottostante. Possiamo inviare i pezzi di fissaggio solamente per mezzo di questo procedimento. Qualora dovete avere qualche reclamo in merito al mobile, allora Vi preghiamo di rivolgerVi direttamente al Vostro Negozio di mobili.

BG Ние нямат директна услуга за обект
Ако липсват части от комплекта, потърнете настоящата справка в картата и не я прагнете на e-mail адреса, защото по този начин можем да доставим само повредени обекти от обекта. Ако у вас има друг дефект на мебелта, Ви съветваме да се обадите или посетите нашия магазин, от който сте закупили стаята.

NL Onze dienstverleiher voor zwaar onterstelen
Wanneer er een onderdeel ontbreekt, kunt u deze servicekaart direct aan onze afdeling e-mailen. Het is echter belangrijk dat u ons niet alleen beschadigde voorwerpen stuurt. Mocht u een ander probleem aan uw meubel hebben, verzeken wij u contact op te nemen met uw meubeldealer.

PL Nasz bezpośredni serwis części montażowych
Jeżeli brakuje części koniecznych do montażu, prosimy o przesłanie nam niniejszej karty serwisowej na niżej podany adres e-mailowy. W ten sposób możemy przesłać. Partiami tylko uszkodzone części. W przypadku innych reklamacji dotyczących mebla, prosimy zgłosić się do salonu meblowego, w którym został dokonany zakup.

HR Servis za otkaz
U slučaju da nedostaje neki od dijelova molimo vas da se dalje posvetite mail adresu koji je naveden ispod. Na ovaj način mogu se dostaviti samo otkazi. U slučaju da imate dodatne prigovore vezane uz komad namještaja molimo vas da se obratite izravno trgovini namještaja gdje je isti kupljen.

HU Direktrendelésünk vesztettik esetén
Ha hiányzik egy vasalat, azt a hiányzó kiegészítőt elküldhet az alább található címre. Azonban csak vesztettik tudunk így kiküldeni. Amennyiben másféle reklamációt írt le, forduljon közvetlenül a boltiüzletéhez.

SK Náš priamy servis pre ťažké škody
Ak by Vám chýbala niekedy časť kovania, môžete poslať túto servisnú kartu poštou e-mailom na nižšie uvedenú adresu. Dňu kovania vieme poslať iba týmto spôsobom. Ak by ste mali inú reklamáciu ohľadom vášho nábytku, obráťte sa priamo na Vašu predajňu nábytku.

SLO Naše direktna služba za težke škodice
V tem primeru, koleda kakor škodice, lahko to servisno kartico pošljete po e-pošti direktno na spodnji naslov. Po tej poti vam lahko pošljemo samo okoli. Če želite reklamirati kakšen drug del pohištva, se obrnite neposredno na vašo trgovino pohištva.

RO Servisul nostru direct pentru feronerie
In cazul in care va lipsesc o piesa de feronerie puteti sa trimiti direct acest card de service prin e-mail la adresa de mai jos. Noi nu putem expedia piesa de feronerie decat pe aceasta cale. Dacă aveți o altă reclamație referitoare la piesa de mobilier, atunci vă rugăm să vă adresați direct la magazinul dvs. de mobilier.

RUS Наш прямой сервис для поставки фурнитуры
Если случится, что Вам не хватает того или иного элемента фурнитуры, Вы можете отправить справку в карту по факсу непосредственно на нижеприведенный адрес электронной почты. Однако, таким образом мы можем переслать лишь фурнитуру. Если же у Вас возникнет иная претензия относительно приобретенной мебели, пожалуйста, обращайтесь непосредственно в организацию, осуществляющую продажу.

S Vår direktservice för beslagdelar
Om du saknar en beslagdel kan du skicka detta servicekort direkt till e-postadressen som anges nedan. Tillik på att detta är den enda möbelservice vi skicka beslagdelar till. Om du vill reklamera en möbel av en annan anledning måste du kontakta ditt möbelslag direkt.

ES Nuestro servicio directo para accesorios
Si le falta algún accesorio, puede enviar esta tarjeta de servicio directamente a la siguiente dirección. No obstante, por esta vía sólo se pueden enviar accesorios. Si tiene alguna otra objeción sobre su mueble, consulte directamente con su mueblería.

TR Doğrudan işin doğrudan servisi
Eğer donatılarınızdan bir parçanın eksik olduğunu fark ederseniz, bu parçanın adresini aşağıdaki bulanan adrese doğrudan mail yollayabilirsiniz. Sadece bu yolla donatılar gönderilebilir. Mobilyanızda başka şikayetleriniz varsa lütfen doğrudan mobilya satıcınıza derişin.

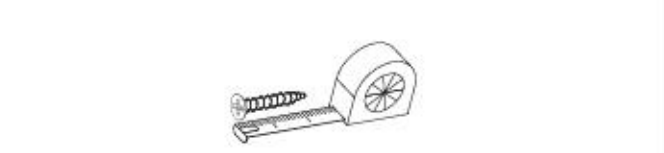

B1 ø8x35 x...	B3 ø8x60 x...	A1 ø7x50 x...
W2 x...	I7 x...	K1 x...
K10 x...	D4 x...	C6 x...
G34 3,5x16 x...	K12 x...	G49 4x16 x...
F13 x...	Z6 x...	I1 x...
F2 x...	M11 x...	G50 3x20 x...
P10 x...	G36 4x30 x...	



Name • Nom • Nome • Naam • Nazwa • Jméno
• Názov • Név • Denumire • İsim • Имя
CITY / GIRON --- 56

D Unser Dienstverleiher ist beschädigt
Solte Ihnen ein Beschädigter fallen, können Sie diese Servicekarte direkt an die untenstehende Adresse mailen. Wir können allerdings nur Beschädigte auf diesem Wege verschicken. Sollten Sie eine andere Beanstandung an Ihrem Möbelstück haben, so wenden Sie sich bitte direkt an Ihr Möbelhaus.

GB Our direct order service for filing
If a filing part is missing, you can e-mail this service card directly to the address below. However, we can only send filing parts in this way if you have any other cause for complaint concerning your item of furniture, please contact your furniture store directly.

CZ Naše přímá služba pro škody
Chytrá vám nějaký díl z kování, můžete tuto servisní kartu odeslat e-mailem přímo na níže uvedenou adresu. Touto cestou však můžeme rozeslat jen díly kování. Pokud byste reklamovali jiný díl nábytku, obraťte se přímo na svého prodejce nábytku.

F Rien acheter la notice de montage
Si vous manque une ferrure, veuillez envoyer directement la présente carte service à l'adresse e-mail indiquée ci-dessous. Cependant, ce nous permet uniquement d'envoyer des ferrures. Pour tout autre type de réclamation concernant votre meuble, veuillez contacter directement votre magasin d'aménagement.

I Il nostro servizio diretto per i ordini delle ferrature
Qualora Vi dovesse mancare un pezzo di ferratura, allora Vi preghiamo di inviare questa carta di servizio immediatamente all'indirizzo sottostante. Possiamo inviare i pezzi di fissaggio solamente per mezzo di questo procedimento. Qualora dovete avere qualche reclamo in merito al mobile, allora Vi preghiamo di rivolgerVi direttamente al Vostro Negozio di mobili.

BG Ние нямат директна услуга за обект
Ако липсват части от комплекта, потърнете настоящата справка в картата и не я прагнете на e-mail адреса, защото по този начин можем да доставим само повредени обекти от обекта. Ако у вас има друг дефект на мебелта, Ви съветваме да се обадите или посетите нашия магазин, от който сте закупили стаята.

NL Onze dienstverleiher voor zwaar onterstelen
Wanneer er een onderdeel ontbreekt, kunt u deze servicekaart direct aan onze afdeling e-mailen. Het is echter belangrijk dat u ons niet alleen beschadigde voorwerpen stuurt. Mocht u een ander probleem aan uw meubel hebben, verzeken wij u contact op te nemen met uw meubeldealer.

PL Nasz bezpośredni serwis części montażowych
Jeżeli brakuje części koniecznych do montażu, prosimy o przesłanie nam niniejszej karty serwisowej na niżej podany adres e-mailowy. W ten sposób możemy przesłać. Partiami tylko uszkodzone części. W przypadku innych reklamacji dotyczących mebla, prosimy zgłosić się do salonu meblowego, w którym został dokonany zakup.

HR Servis za otkaz
U slučaju da nedostaje neki od dijelova molimo vas da se dalje posvetite mail adresu koji je naveden ispod. Na ovaj način mogu se dostaviti samo otkazi. U slučaju da imate dodatne prigovore vezane uz komad namještaja molimo vas da se obratite izravno trgovini namještaja gdje je isti kupljen.

HU Direktrendelésünk vesztettik esetén
Ha hiányzik egy vasalat, azt a hiányzó kiegészítőt elküldhet az alább található címre. Azonban csak vesztettik tudunk így kiküldeni. Amennyiben másféle reklamációt írt le, forduljon közvetlenül a boltiüzletéhez.

SK Náš priamy servis pre ťažké škody
Ak by Vám chýbala niekedy časť kovania, môžete poslať túto servisnú kartu poštou e-mailom na nižšie uvedenú adresu. Dňu kovania vieme poslať iba týmto spôsobom. Ak by ste mali inú reklamáciu ohľadom vášho nábytku, obráťte sa priamo na Vašu predajňu nábytku.

SLO Naše direktna služba za težke škodice
V tem primeru, koleda kakor škodice, lahko to servisno kartico pošljete po e-pošti direktno na spodnji naslov. Po tej poti vam lahko pošljemo samo okoli. Če želite reklamirati kakšen drug del pohištva, se obrnite neposredno na vašo trgovino pohištva.

RO Servisul nostru direct pentru feronerie
In cazul in care va lipsesc o piesa de feronerie puteti sa trimiti direct acest card de service prin e-mail la adresa de mai jos. Noi nu putem expedia piesa de feronerie decat pe aceasta cale. Dacă aveți o altă reclamație referitoare la piesa de mobilier, atunci vă rugăm să vă adresați direct la magazinul dvs. de mobilier.

RUS Наш прямой сервис для поставки фурнитуры
Если случится, что Вам не хватает того или иного элемента фурнитуры, Вы можете отправить справку в карту по факсу непосредственно на нижеприведенный адрес электронной почты. Однако, таким образом мы можем переслать лишь фурнитуру. Если же у Вас возникнет иная претензия относительно приобретенной мебели, пожалуйста, обращайтесь непосредственно в организацию, осуществляющую продажу.

S Vår direktservice för beslagdelar
Om du saknar en beslagdel kan du skicka detta servicekort direkt till e-postadressen som anges nedan. Tillik på att detta är den enda möbelservice vi skicka beslagdelar till. Om du vill reklamera en möbel av en annan anledning måste du kontakta ditt möbelslag direkt.

ES Nuestro servicio directo para accesorios
Si le falta algún accesorio, puede enviar esta tarjeta de servicio directamente a la siguiente dirección. No obstante, por esta vía sólo se pueden enviar accesorios. Si tiene alguna otra objeción sobre su mueble, consulte directamente con su mueblería.

TR Doğrudan işin doğrudan servisi
Eğer donatılarınızdan bir parçanın eksik olduğunu fark ederseniz, bu parçanın adresini aşağıdaki bulanan adrese doğrudan mail yollayabilirsiniz. Sadece bu yolla donatılar gönderilebilir. Mobilyanızda başka şikayetleriniz varsa lütfen doğrudan mobilya satıcınıza derişin.

nr	L[mm]	B[mm]	T[mm]	Menge	Coll
1	1200	400	16	1	2/2
2	1155	323	16	1	2/2
3	1200	400	16	1	2/2
4	968	366	16	1	1/2
5	476	322	16	4	1/2
6	476	322	16	1	1/2
7	476	322	16	1	1/2
8	968	362	16	1	1/2
9	968	80	16	1	2/2
10	968	77	38	1	2/2
11	571	480	16	4	2/2
12	1170	489	3	1	2/2
13	1170	489	3	1	2/2

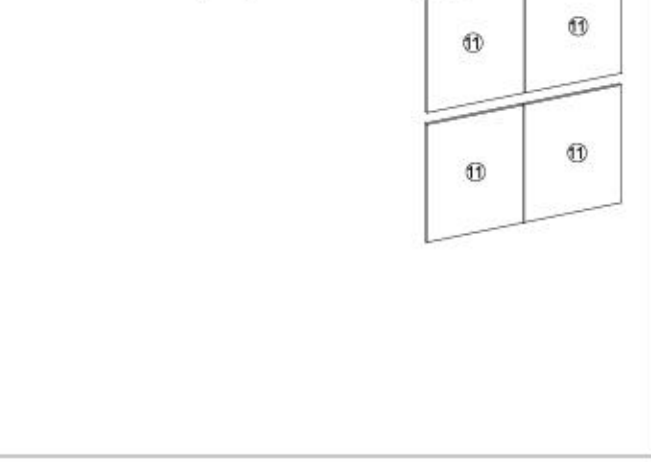
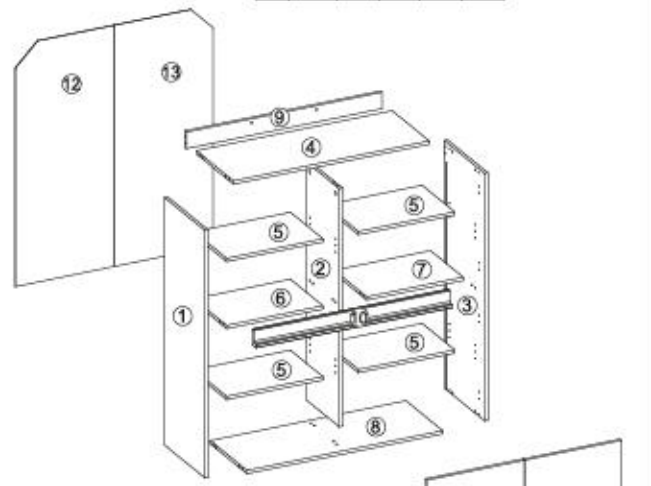



- Ⓓ **Montageanleitung**
- Ⓐ **Handleiding voor de montage**
- Ⓙ **Montaj talimatı**
- Ⓕ **Notice de montage**
- Ⓒ **Montážní návod**
- Ⓗ **Szerelési útmutató**
- Ⓖ **Assembly Instructions**
- Ⓟ **Instrukcja montażu**
- Ⓡ **Инструкция по монтажу**
- Ⓣ **Istruzioni di montaggio**
- Ⓚ **Návod na montáž**
- Ⓡ **Instrucțiunile de montaj**
- Ⓔ **Instrucciones de montaje**
- Ⓡ **Montaj Talimatı**

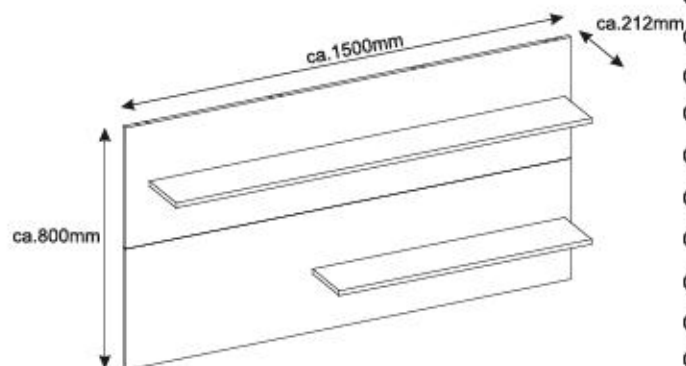

nr	L[mm]	B[mm]	T[mm]	Menge	Colt
1	1500	400	16	1	1/1
2	1500	400	16	1	1/1
3	1400	180	16	1	1/1
4	850	180	16	1	1/1
5	1450	65	16	1	1/1
6	1450	65	16	1	1/1
7	750	65	16	2	1/1

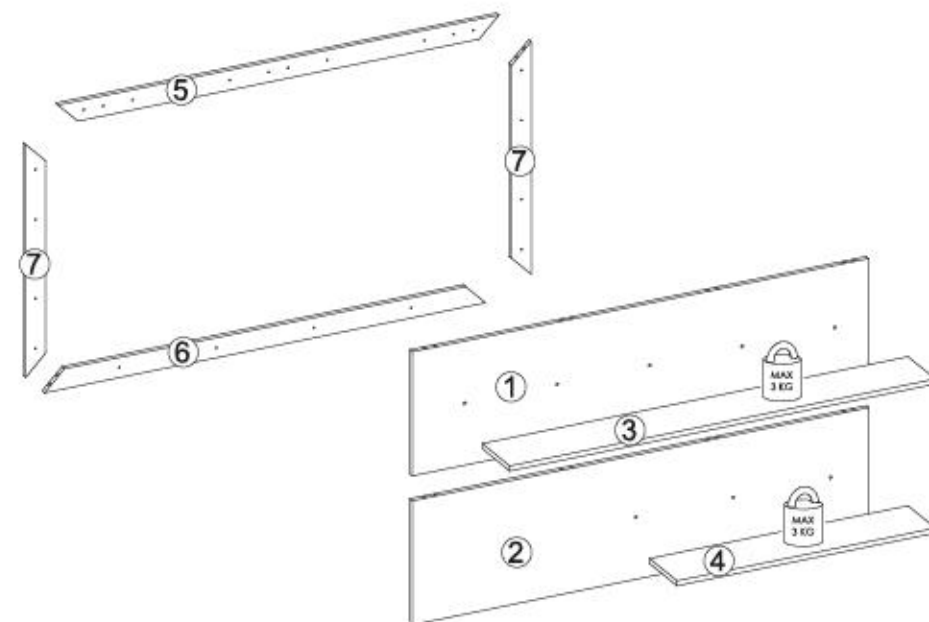
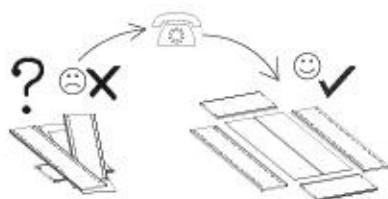
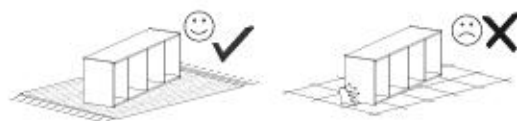
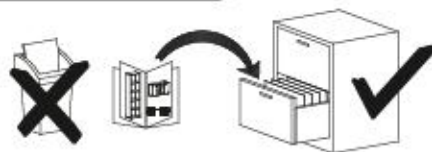
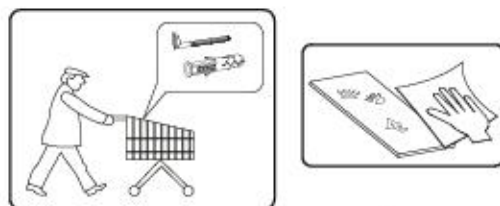
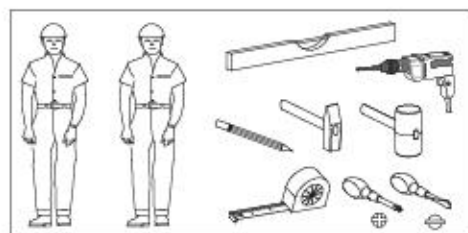

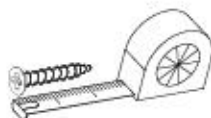
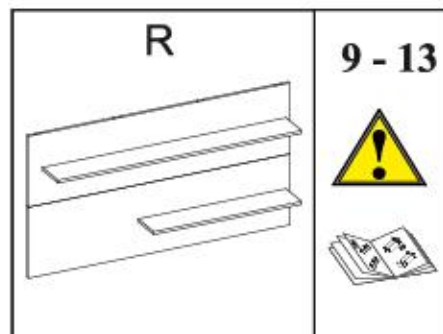
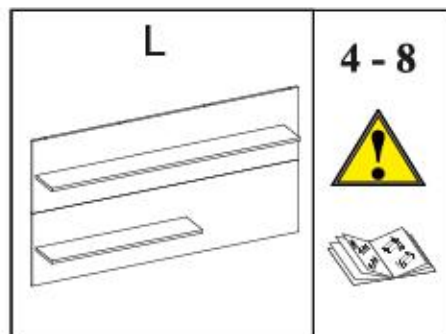

A1 ø7x50 x8	W2 x1	G52 5x11 x6	P10 x3	B1 ø8x30 x12
K1 x8	K12 x4	G36 4x30 x22	I10 ø8 x16	

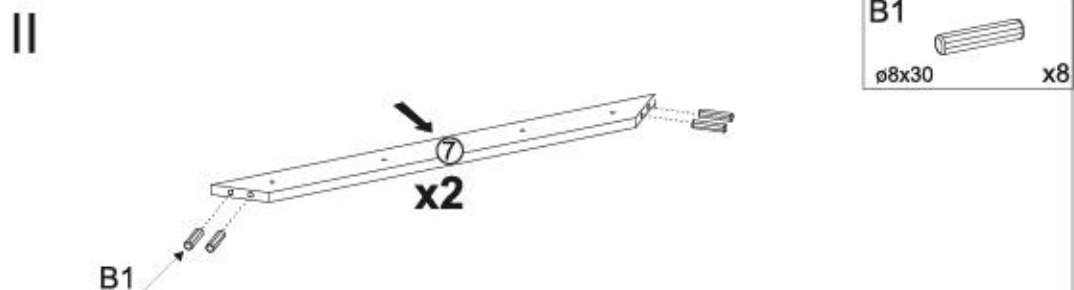
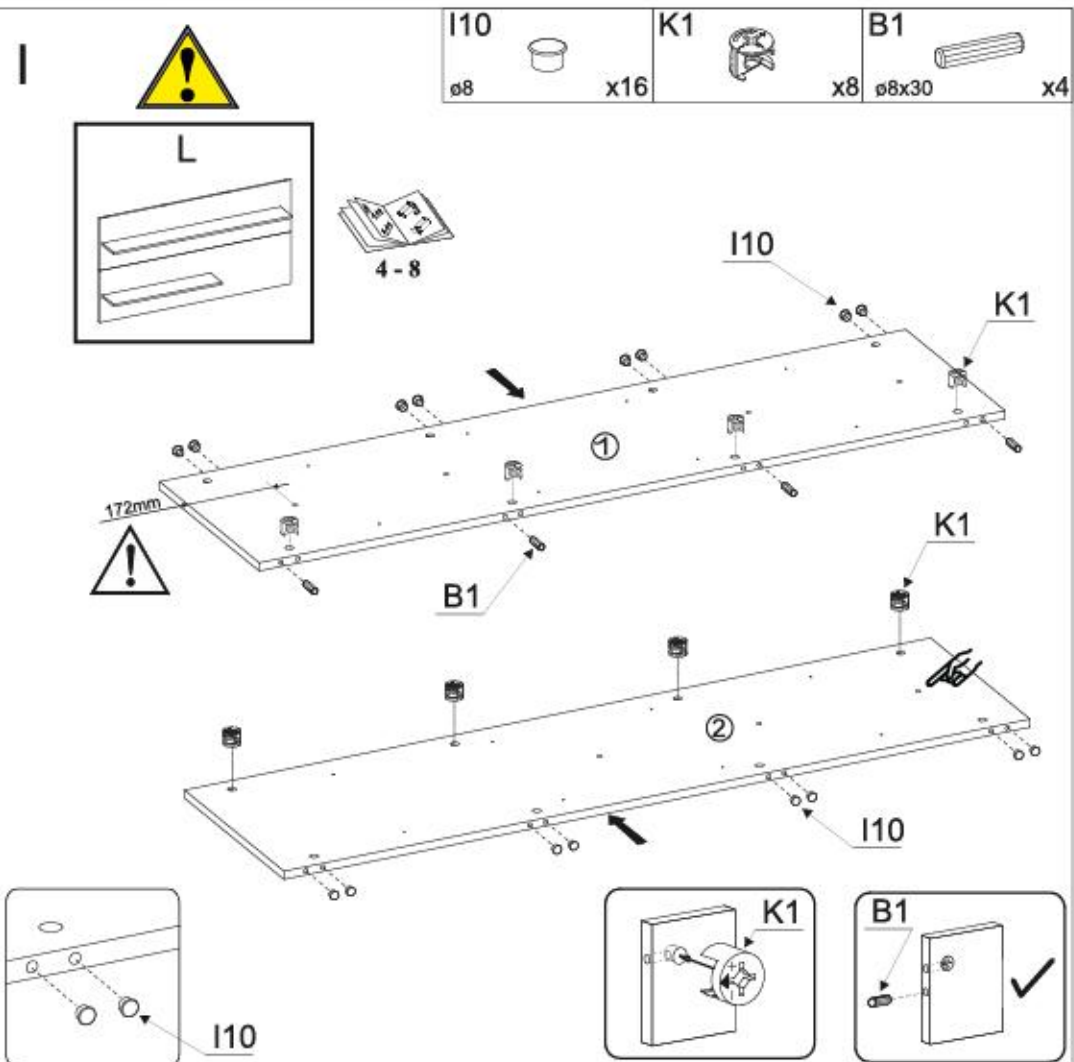
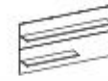

5/14

CITY / GIRON 72



III

G52



5x11

x6

P10



x3

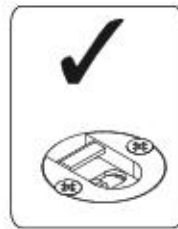
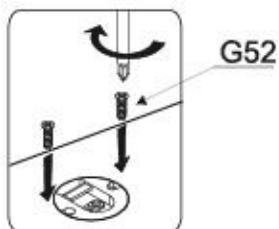
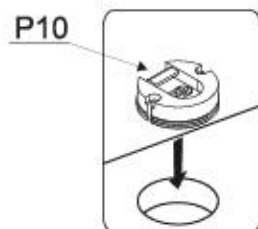
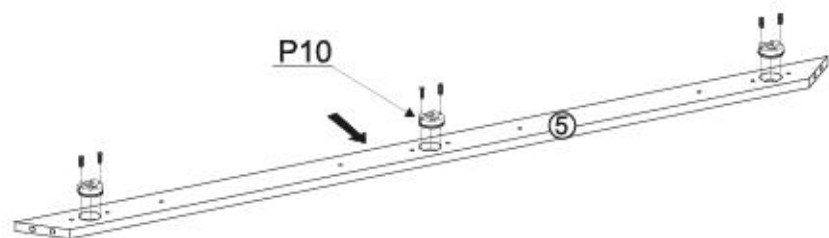

IV

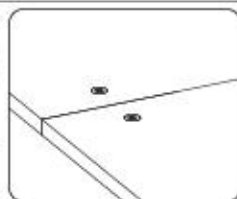
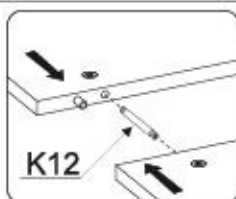

K12



x4

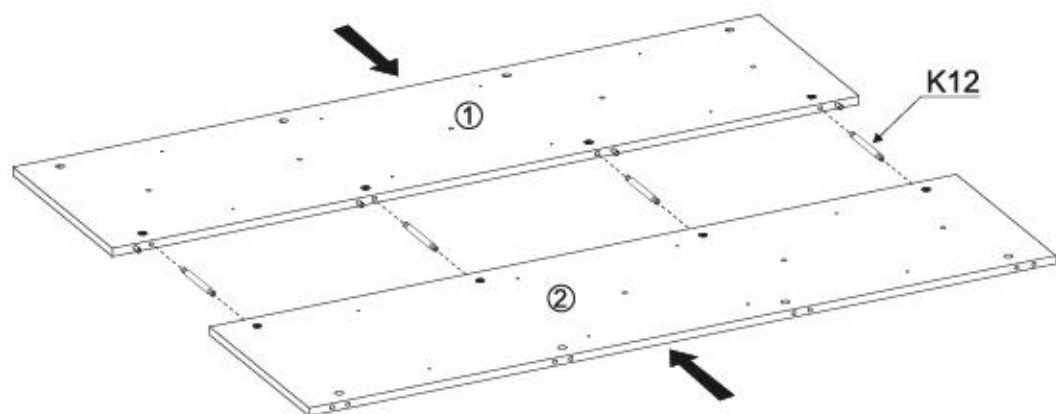

6/14

CITY / GIRON 72



V

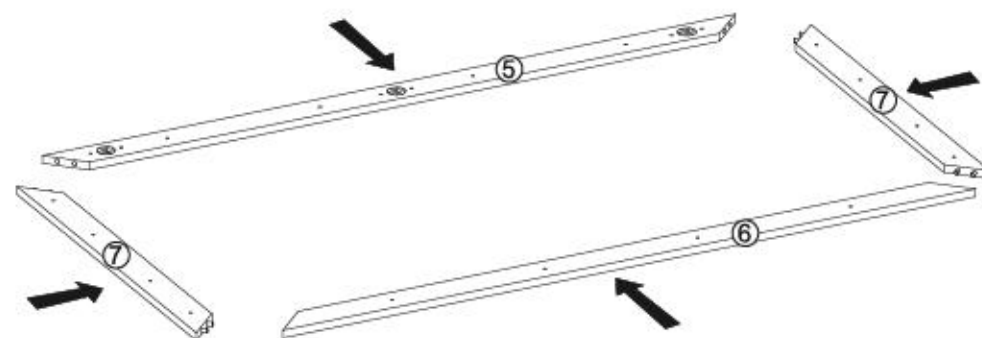

VI

G36



4x30

x22

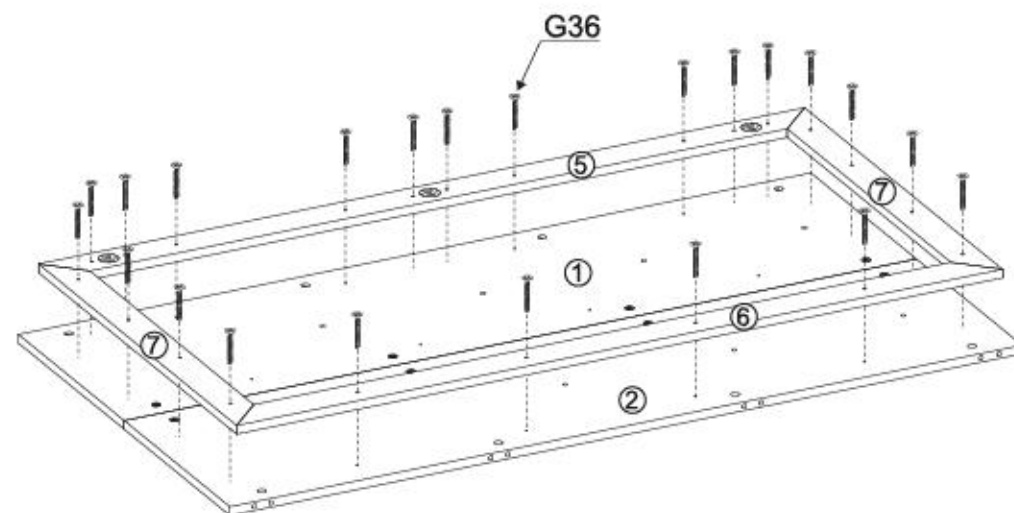

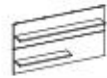

VII

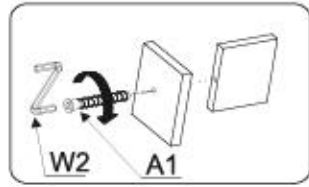

A1



ø7x50

x8

W2



x1

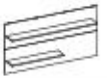
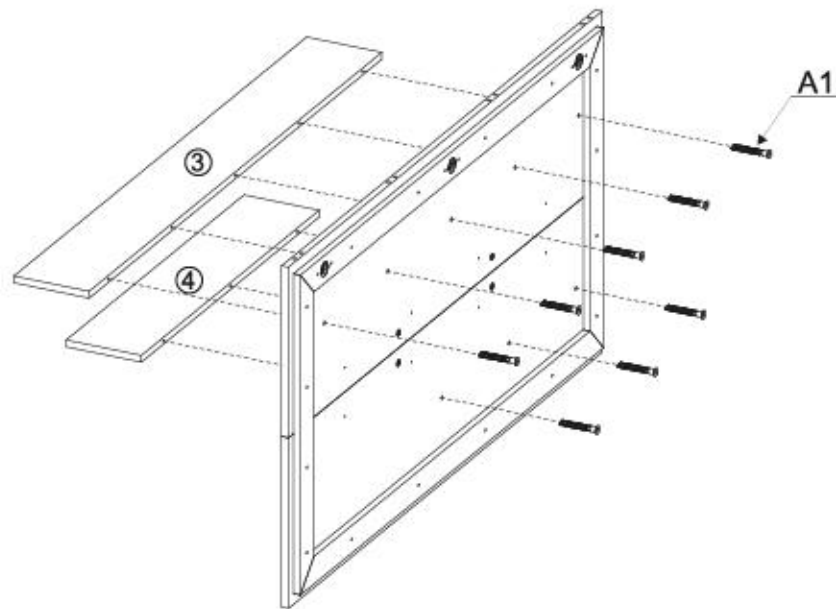

VIII

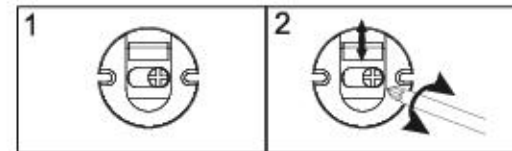
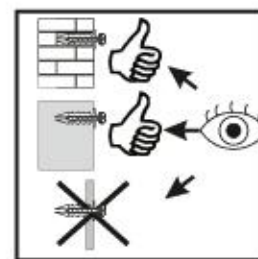
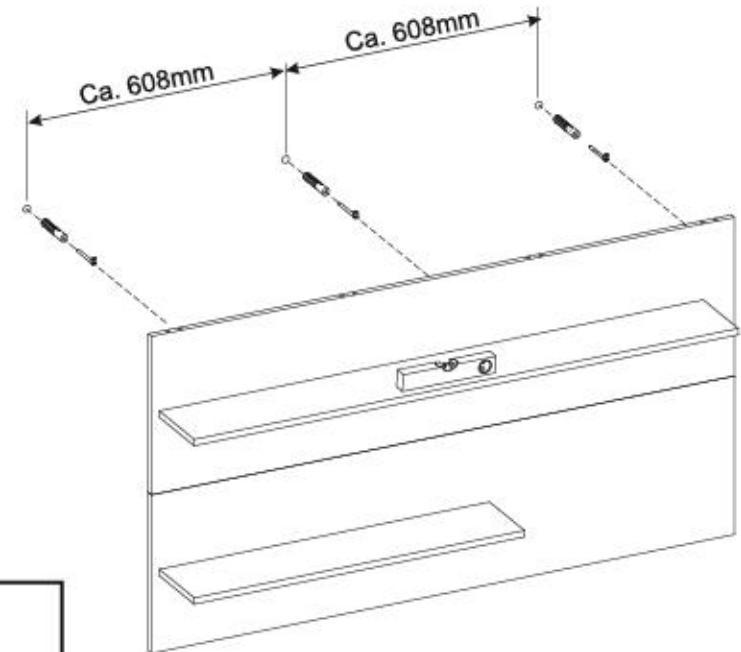
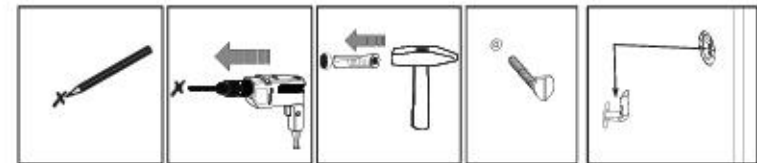
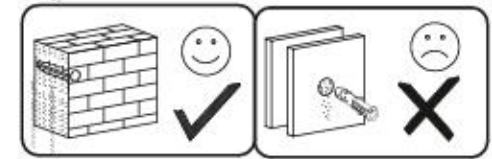

9/14

CITY / GIRON 72



IX

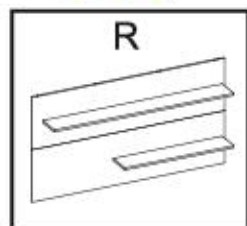

I10



x16

K1



x8

B1



ø8x30 x4

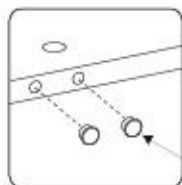
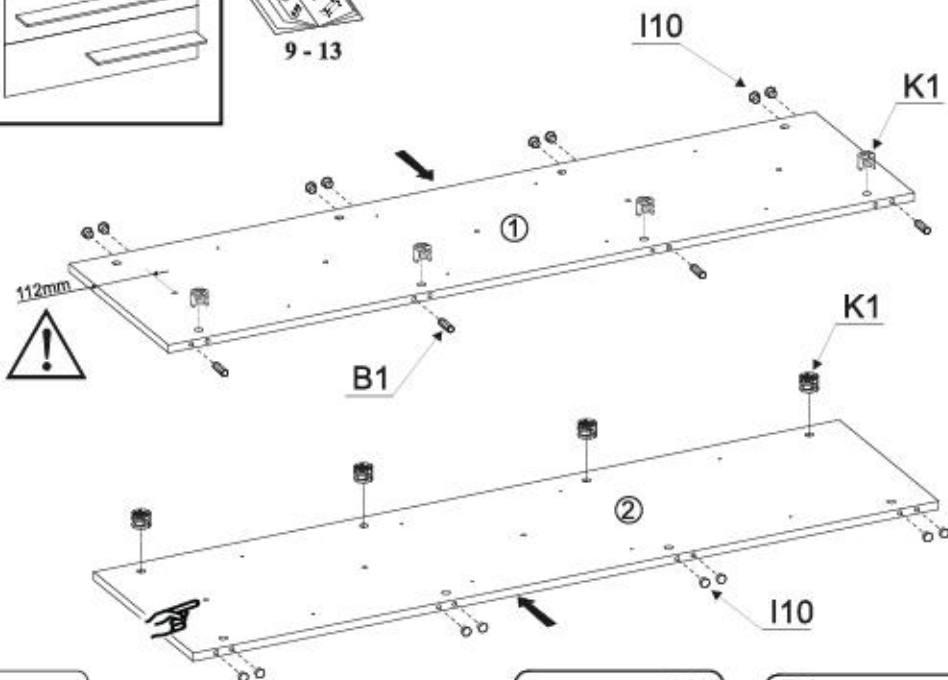

I10

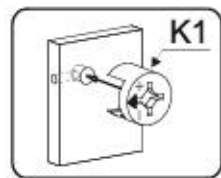

K1

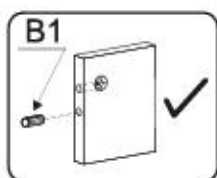

B1

X

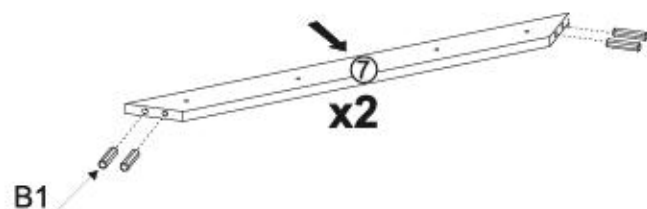

B1

x2

B1



ø8x30 x8

10/14

CITY / GIRON 72



XI

G52



5x11

P10



x6

x3

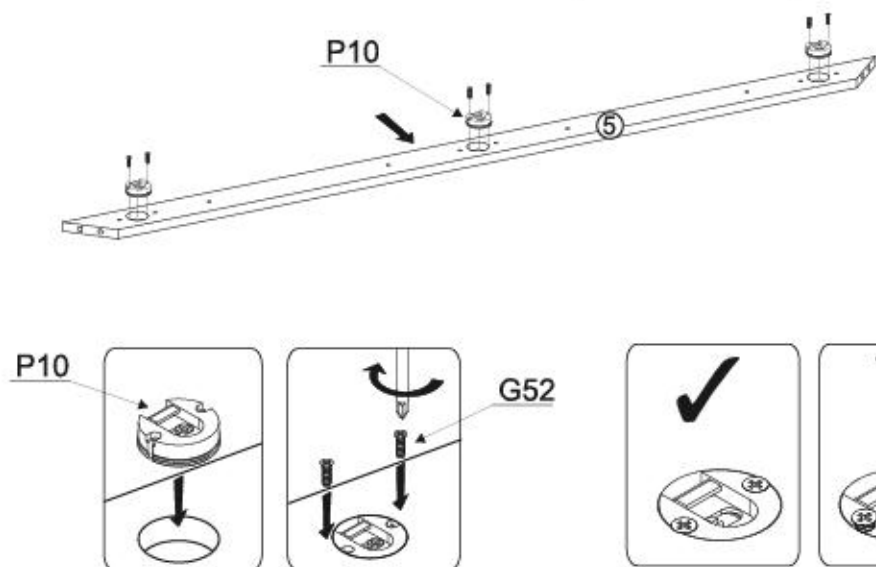

P10

G52

XII

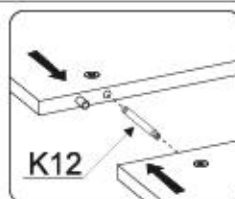

K12

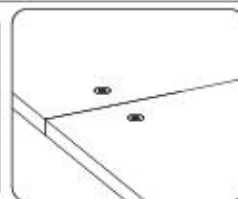

K12



x4

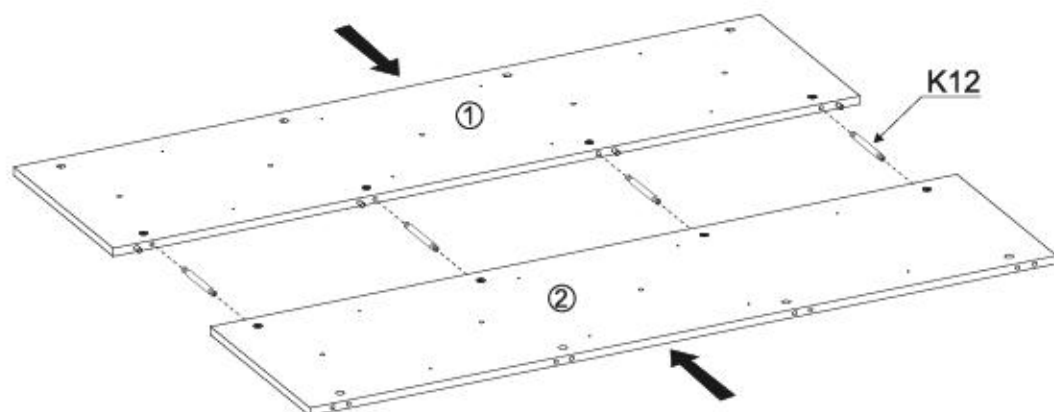

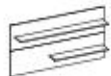

XIII

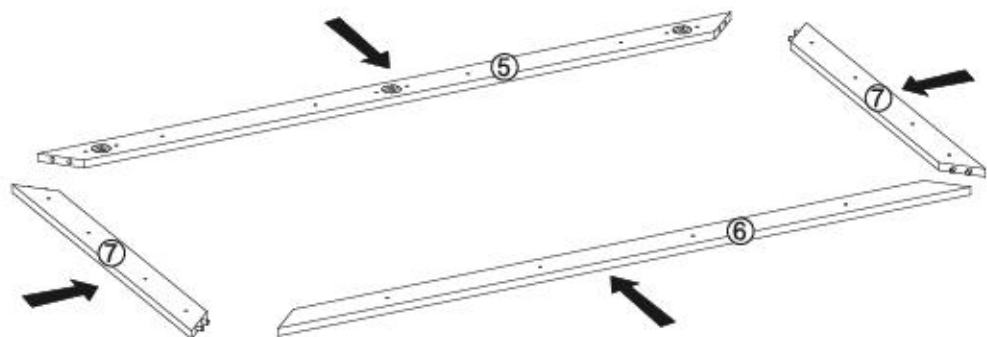

XIV

G36



4x30 x22

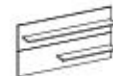
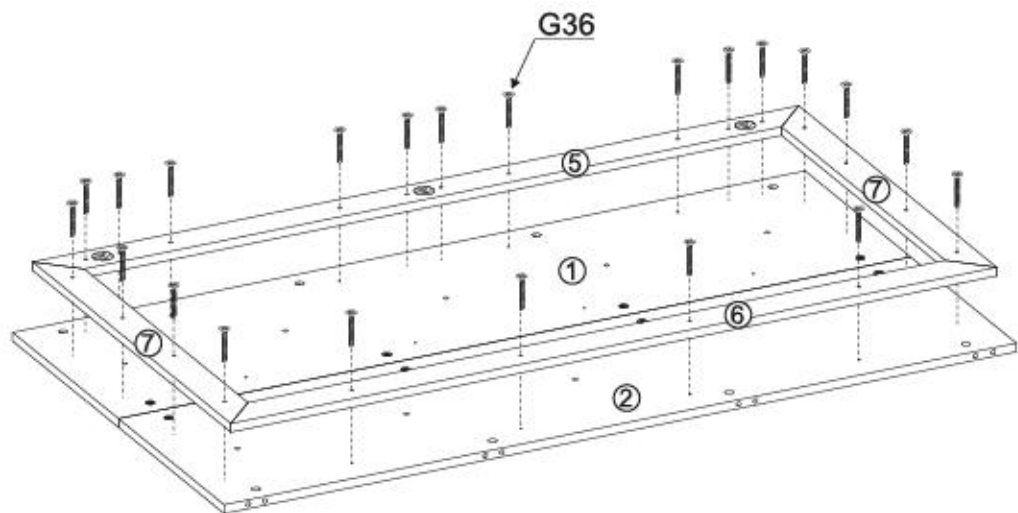

XV

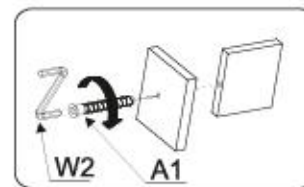

A1

ø7x50 x8

W2



x1

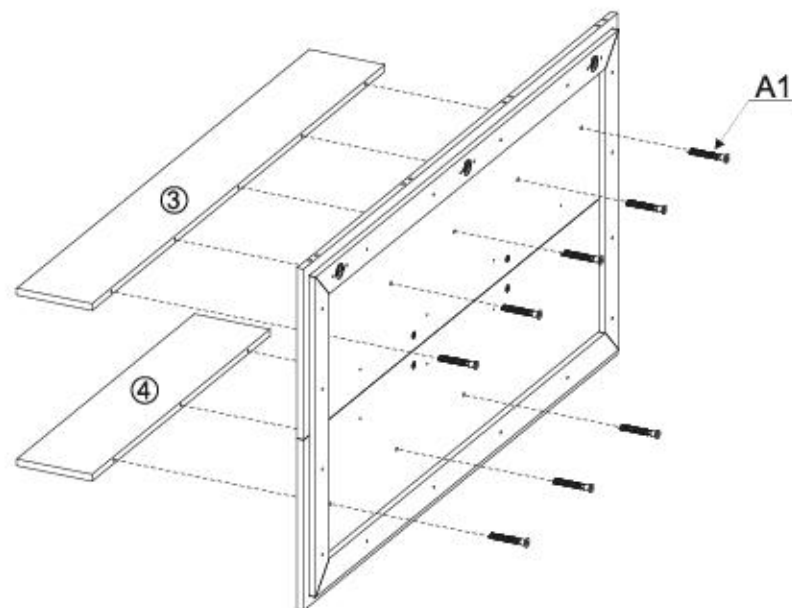



XVI

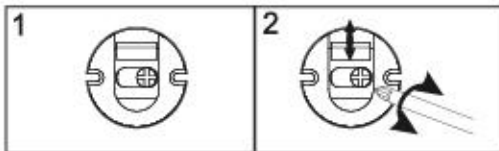
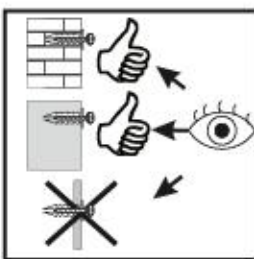
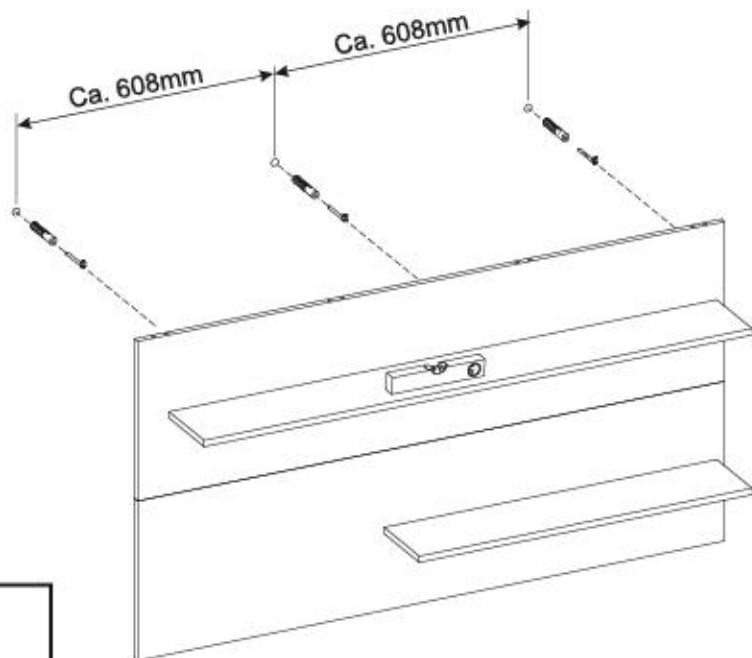
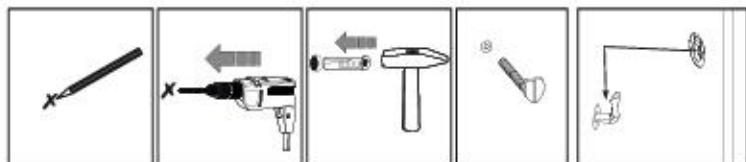

Name • Nom • Nome • Naom • Nazwa • Jméno
• Názov • Név • Denumire • Isim • Имя

Nr • No • N° • Номер • Č • Sz

Typ • Type • Tip • Típus • Típo • Тип

CITY / GIRON

--

72

D Unser Direktservice für Beschädigte
Sollte Ihnen ein Beschädigter Service, können Sie diese Servicekarte direkt an die untenstehende Adresse mailen. Wir können allerdings nur Beschädigte auf diesem Wege verschicken. Sollten Sie eine andere Beanstandung an Ihren Möbelstück haben, so wenden sie sich bitte direkt an Ihr Möbelhaus.
GB Our direct order service for fitting
If a fitting part is missing, you can e-mail this service card directly to the address below. However, we can only send fitting parts in this way if you have any other cause for complaining your firm of furniture, please contact your furniture store directly.

CZ Náš přímý službu pro poškození
Chybí-li vám nějaký díl z kování, můžete tuto službu kartu odeslat e-mailem přímo na níže uvedenou adresu. Touto cestou však můžeme rozeslat jen díly kování. Pokud byste reklamovali jiný díl nábytku, obraťte se přímo na svého prodejce nábytku.

F Rien attacher la notice de montage
Si votre marque une fissure, veuillez envoyer directement la présente carte service l'adresse e-mail indiquée ci-dessous. Cependant, ce nous permet uniquement d'envoyer des ferrures. Pour tout autre type de réclamation concernant votre meuble, veuillez contacter directement votre magasin d'ameublement.

I Il nostro servizio diretto per l'ordine delle ferramentie
Qualora Vi dovesse mancare un pezzo di fissaggio, allora Vi preghiamo di inviare questa carta di servizio immediatamente all'indirizzo sottostante. Possiamo inviare i pezzi di fissaggio solamente per mezzo di questo procedimento. Qualora dovete avere qualche altra reclamazione in merito al mobile, allora Vi preghiamo di rivolgerVi direttamente al Vostro Negozio di mobili.

BG Насявта директна услуга за обект
Ако липоват част от комплекта, потулката настройката сервиза карта и не е направено на е-мал адреса, моляваме ви да пишете на този адрес. Ако имате друга жалба по мебелите, ще ви помолим да се обърнете към местната експлоатация, от който сте закупили мебелите.

NL Onze directservice voor lasse onderdelen
Wanneer er een onderdeel ontbreekt, kunt u deze servicekaart direct aan onderstaand e-mailadres sturen. Wij kunnen langa deze weg echter alleen beslagdelen versturen. Mocht u een ander probleem aan uw meubel hebben, verzoeken wij u contact op te nemen met uw meubeldealer.

PL Nasz bezpośredni serwis części metalowych
Jeżeli brakuje części konstrukcyjnej do montażu, prosimy o przesłanie nam niniejszej karty serwisowej na niżej podany adres e-mailowy. W ten sposób możemy przesłać Parafunki tylko konstrukcyjne części. W przypadku innych reklamacji dotyczących mebla, prosimy zgłosić się do salonu meblowego, w którym został dokonany zakup.

HR Servis za stolu
U slučaju da nedostaje neki od dijelova metala vas da na dalje navedeno mail adresu pošaljete ovaj servisni obrazac. Na ovaj način mogu se dostaviti samo okovi. U slučaju da imate dodatne prigovore vezane uz komad namještaja molimo vas da se obratite izravno trgovini namještaja gdje je isti kupljen.

HU Direktszolgálatunk vasnak az asztal
Ha hiányzik egy vasalat, azt a kénytelen kivételével elküldhet az alább található címre. Azonban csak vasalakat tudunk így küldeni. Amennyiben másféle reklamációt kíván bejelenteni, kérjük, forduljon közvetlenül a boltvezetőnek.

SK Náš priamy servis za štáň kovania
Ak by Vám chýbala nejaká časť kování, môžete poslať túto servisnú kartu poslať e-mailom na nižšie uvedenú adresu. Dáň kování vieme poslať iba týmto spôsobom. Ak by ste mali inú reklamáciu ohľadom vášho nábytku, obraťte sa priamo na vášho predajcu nábytku.

SLO Náš direktna služba strožim za okovje
Če vam manjka kakšno okovje, lahko to servisno kartico pošljete po e-pošti direktno na spodnji naslov. Po tej poti vam lahko pošljemo samo okovje. Če želite reklamirati kakšen drug del pohištva, se obrnite neposredno na vašo trgovino pohištva.

RO Servisul nostru direct pentru fierare
In cazul in care va lipseste o piesa de fierare puteti sa trimiti direct acest card de service prin e-mail la adresa de mai jos. Noi nu putem expedia piese de fierare decat pe aceasta cale. Dacă aveti o altă reclamație referitoare la piesa de mobilier, atunci vă rugăm să vă adresați direct la magazinul dvs. de mobilier.

RUS Наш прямой сервис для поставки фурнитуры
Если вам не хватает какой-либо детали, вы можете отправить этот сервисный бланк непосредственно на нижеприведенный адрес электронной почты. Однако, таким образом мы можем переслать лишь фурнитуру. Если же у вас имеются другие претензии относительно приобретенной мебели, пожалуйста, обращайтесь непосредственно в организацию, осуществляющую продажу.

S Vår direktservice för beslagdelar
Om du saknar en beslagdel kan du skicka detta servicekort direkt till e-postadressen som anges nedan. Tillräkligt är det enda sättet att skicka beslagdelar till dig. Om du vill reklamera din möbel av en annan anledning måste du kontakta ditt möbelfirma direkt.

ES Nuestro servicio directo para accesorios
Si le falta algún accesorio, puede enviar esta tarjeta de servicio directamente a la siguiente dirección. No obstante, por este método solo podemos enviar accesorios. Si tiene alguna otra objeción sobre su mueble, consulte directamente con su mueblería.

TR Doğrudan İhtiyaçlarınız İçin Servis Kartı
Bir donatı eksikliği ya da servis kartını doğrudan aşağıdaki bulanan adrese gönderen mail yazabilirsiniz. Sadece bu yolla donatılar gönderilebilir. Mobilyanızda başka şikayetleriniz varsa diğer doğrudan mobilya satıcınıza danışın.

Nr	L [mm]	B [mm]	T [mm]	Menge	Cost
1	1500	400	16	1	1/1
2	1500	400	16	1	1/1
3	1400	180	16	1	1/1
4	850	180	16	1	1/1
5	1450	65	16	1	1/1
6	1450	65	16	1	1/1
7	750	65	16	2	1/1

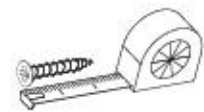
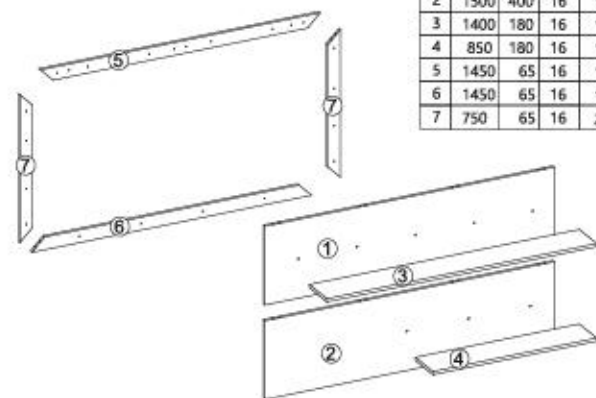

A1 Ø7x50 x...	W2 x...	G52 5x11 x...
P10 x...	B1 Ø8x30 x...	K1 x...
K12 x...	G36 4x30 x...	I10 Ø8 x...

