

1PPASCA3/1YYASCA3

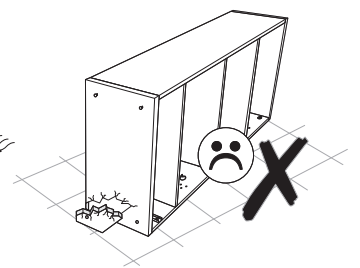
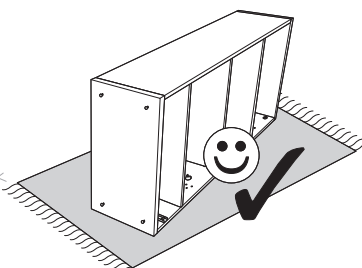
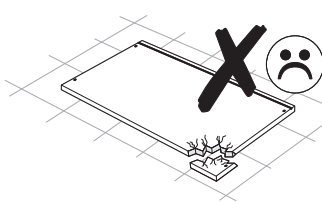
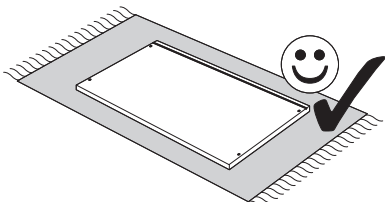
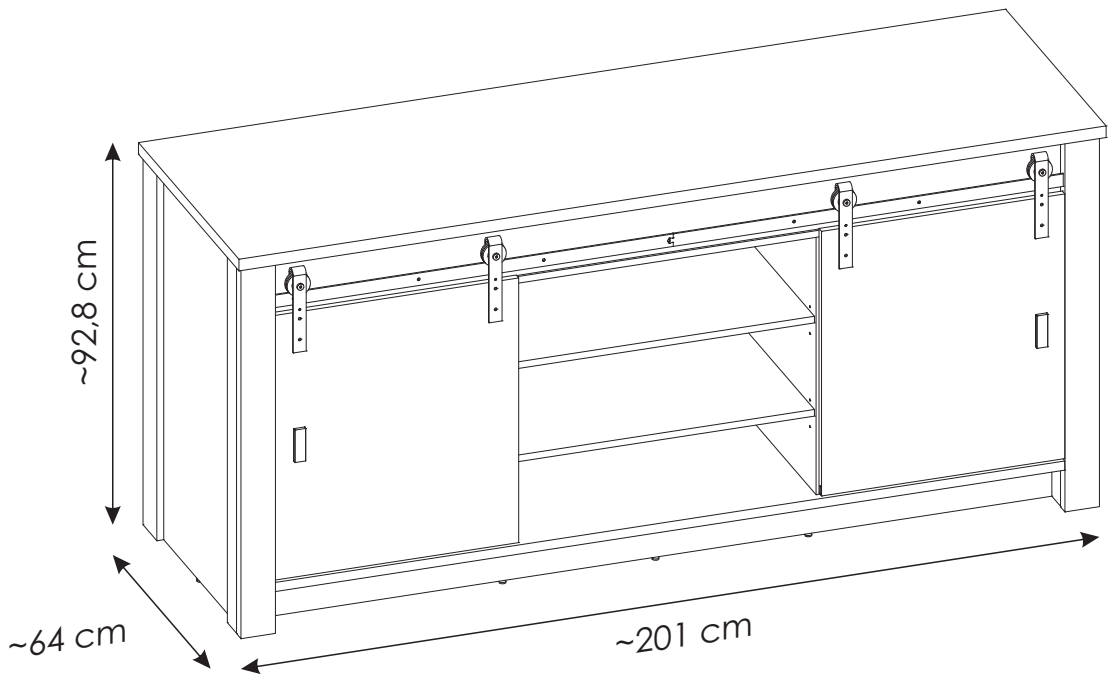
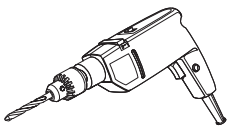
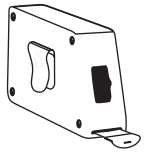
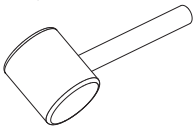
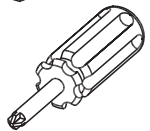
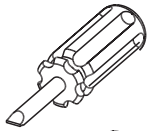
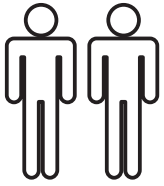

ملاحظة!

يجب تثبيت الأثاث بإحكام إلى الحائط أو الجدار لتجنب خطر إنقلابه. لا تحتوي العلبة على مسامير التثبيت، إذ إنه ينبغي إستعمال المسامير المخصصة لنوعية الحائط أو الجدار. اختر المسامير التي تناسب جدارك.

E.

¡ATENCIÓN! El mueble debe ser fijado permanentemente a la pared para evitar el riesgo relacionado con el vuelco del mueble. En el paquete no hay tornillos de fijación, ya que se debe elegir el tipo de fijación adecuado para el tipo de pared. Elija el apropiado para su tipo de pared.

CN.

注意！本家具需要固定在墙上以免倒塌。箱子里没有安装螺钉。因为安装方式需要根据墙的类型调整。请按照您的墙类型选择合适的安装方式。

SLO.

POZOR! Pohištvo trajno pritrдите na steno, da preprečite tveganje, da se prevrne. V paketu ni pritrđilnih vijakov, saj je treba način pritrđitve ustrezno izbrati glede na vrsto stene. Izberite način, ki je ustrezen za vašo steno.

HU.

FIGYELEM! Rögzítse a bútorokat a falhoz, hogy elkerülje a bútor felborulásának kockázatát. A készletben nem találhatóak rögzítőcsavarok, mivel a rögzítés típusa a fal típusától függ. Válassza ki a fal típusának megfelelő kötőelemeket.

NL.

OPMERKING! De meubelen moeten permanent aan de muur worden bevestigd om te voorkomen dat de meubelen kantelen. Er zitten geen bevestigingsschroeven in het pakket, omdat het type bevestiging moet worden gekozen op basis van het type muur. Kies de juiste voor uw type muur.

EN.

WARNING! To prevent this furniture from tripping over, fix it to the wall permanently. Fixing devices are not included since different wall materials require different types of fixing devices. Please make sure you chose the correct ones for your type of wall.

SK.

POZOR! Nábytok musí byť trvalo pripevnený k stene tak, aby sa zamedzilo riziku prevrátenia. Balík neobsahuje upevňovacie skrutky, pretože typ upevnenia je treba vybrať podľa typu steny. Vyberte typ vhodný pre Vašu stenu.

CZ.

POZOR! Nábytek je nutné pevně připevnit ke zdi, abychom se vyhnuli riziku spojenému s jeho převrnutím. Součástí balení nejsou připevňovací šrouby, protože způsoby připevnění je nutné zvolit podle druhu stěny. Vyberte správný pro Váš typ stěny.

RU.

ПРИМЕЧАНИЕ! Эту мебель необходимо всегда прикреплять к стене, чтобы избежать рисков, связанных с переворотом мебели. В пакете нет крепежных винтов, потому что тип крепления должен быть выбран в соответствии с типом стены. Выберите, пожалуйста, правильные винты к вашей стене.

RO.

ATENȚIE! Mobila trebuie ancorată permanent în perete pentru a evita riscul de răsturnare a mobilei. În pachet nu sunt incluse șuruburile de fixare, deoarece tipul de ancoraj trebuie ales în funcție de tipul de perete. Alegeți șuruburile potrivite pentru tipul Dvs. de perete.

TR.

DİKKAT! Devrilmeye riskini önlemek için mobilya duvara sabitlemelidir. Sabitleme civataları pakete dahil değildir, çünkü sabitleme tertibatının tipi, duvara tipine uygun olarak seçilmelidir. Onu duvarınızın tipine göre seçiniz.

PL.

UWAGA! Mebel należy trwale zamocować do ściany, aby uniknąć ryzyka związanego z przewróceniem się mebla. W paczce nie ma śrub mocujących, ponieważ rodzaj mocowania należy odpowiednio dobrać do rodzaju ściany. Dobierz właściwe do Twojego rodzaju ściany.

D.

ACHTUNG! Um alle mit dem Umkippen des Möbels verbundenen Risiken auszuschließen, muss das Möbel fest an der Wand verankert werden. Beschläge für die Wandbefestigung sind nicht beige packt, da diese von der jeweiligen Wandbeschaffenheit abhängig sind. Bitte solche Befestigungsschläge wählen, die für die heimischen Wände geeignet sind.

FR.

ATTENTION! Ce meuble doit être fixé en permanence au mur pour éviter les risques de chute. Les vis de fixation ne sont pas livrées car le type de fixation doit être choisi en fonction du type de mur. Sélectionnez les fixations adaptées au mur.

I.

ATTENZIONE! Il mobile deve essere permanentemente fissato alla parete per evitare i rischi derivanti da un ribaltamento del mobile. La confezione non include le viti di fissaggio, in quanto il tipo di fissaggio deve essere scelto in base al tipo di parete. Utilizzare viti appropriate in base al materiale della parete.









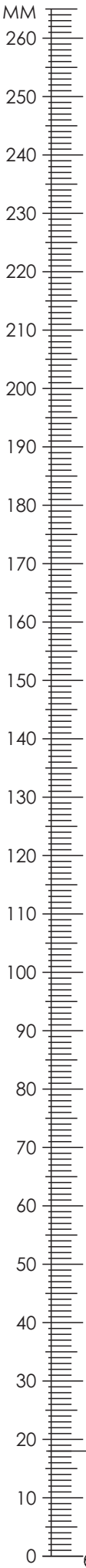



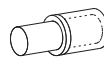
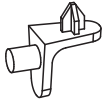

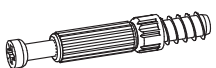
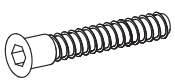
HR.

NAPOMENA! Namještaj mora biti trajno pričvršćen za zid, kako bi se izbjegao rizik od njegovog prevrtanja. U paketu nema vijaka za pričvršćivanje, jer se vrsta montaže mora prilagoditi vrsti zida. Odaberite pravu vrstu prema Vašoj vrsti zida.

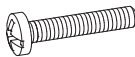
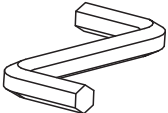

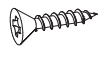
1PPASCA3/1YYASCA3

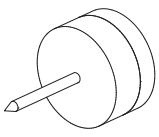

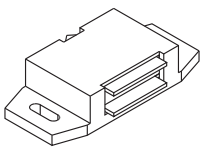
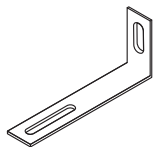
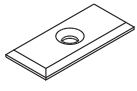
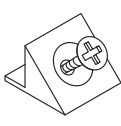
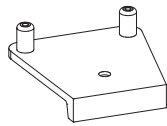
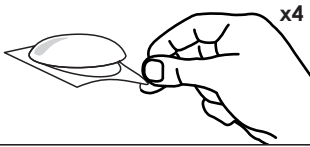
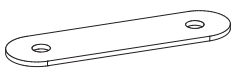
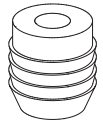
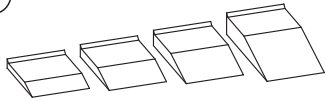
A0 8 x 20 mm x8 	A1 8 x 35 mm x58 	D2  x16
D6  x8	E0 Ø16 x6 	E1 15 x 12 mm x36 
F1 6 x 34 mm x36 	G2 7 x 60 mm x8 	H2 L - 78 mm x2 
I0 3 x 13 mm x4 	I2 4 x 16 mm x2 	K7 4 x 22 mm x4 
M  x1	M1  x1	N0 3 x 13 mm x4 
N1 3 x 16 mm x30 	N14 4 x 30 mm x12 	O2  x12
P16  x4	Q1  x2	Q9  x2
R1  x10	R4  x10	R5  x4
R8  x4	R10  x2	S17  x8
Z  x1		

1PPASCA3/1YYASCA3

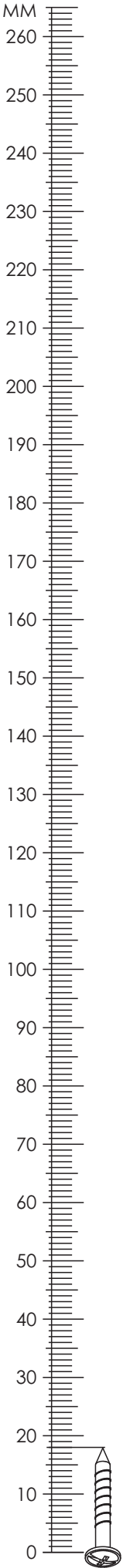

BE SC 18 28 00

x1

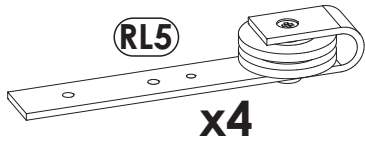
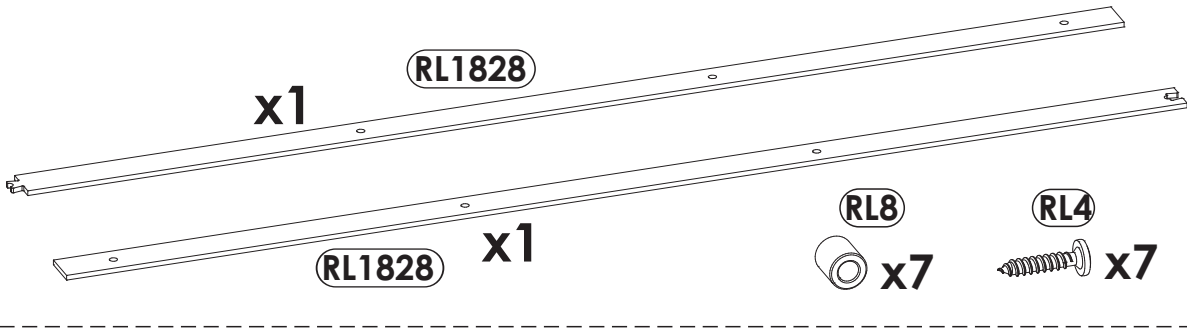

1PPASCA3/1YYASCA3

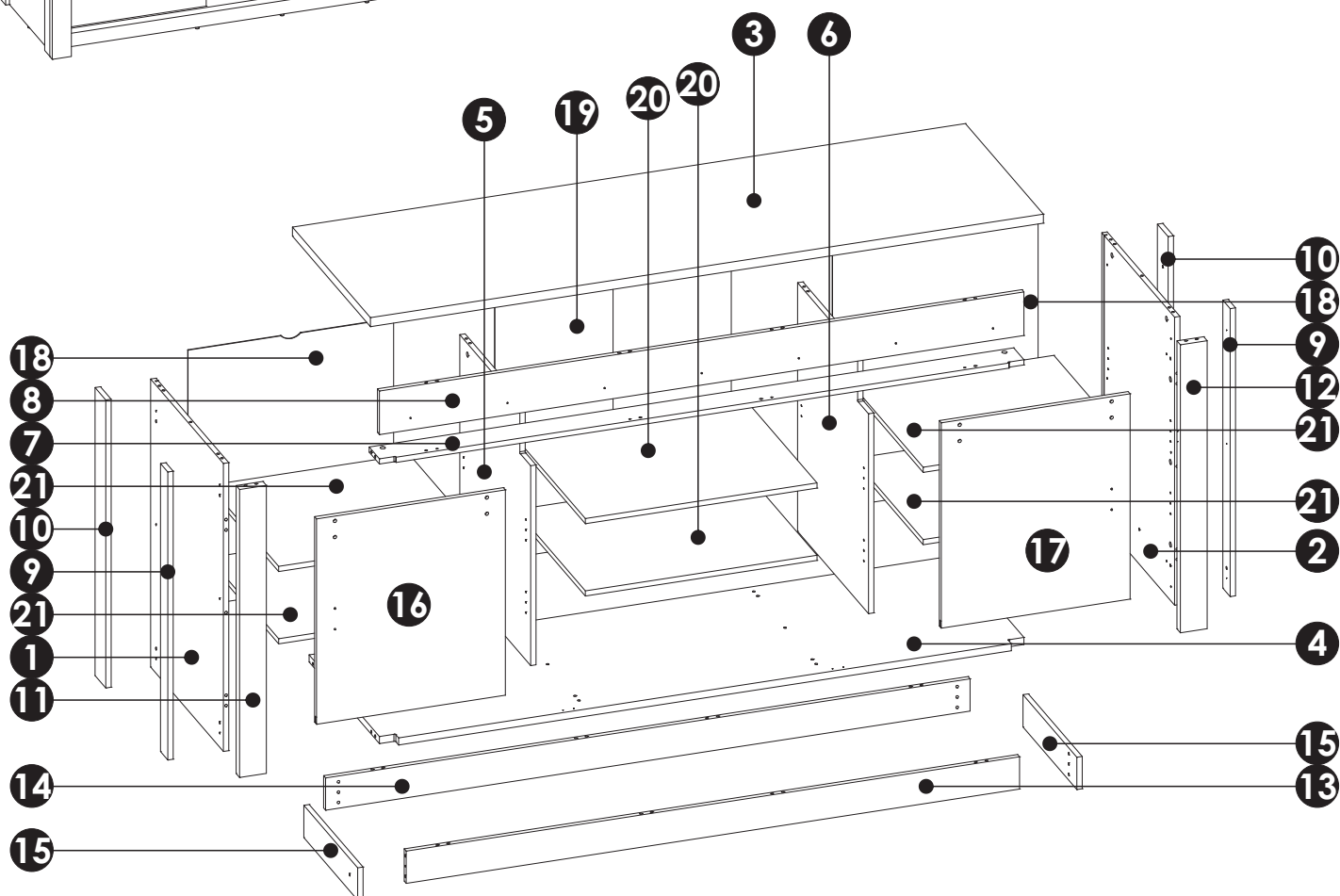
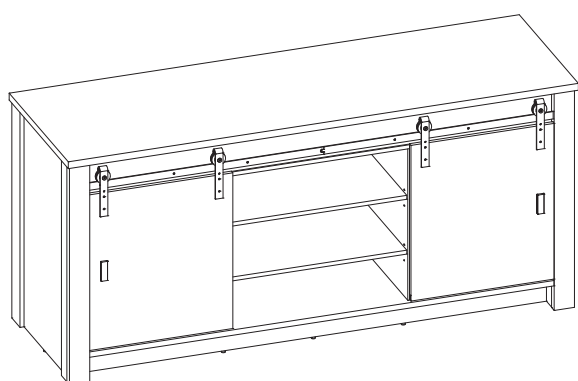

1	892	597	16	x1	1/4
2	892	597	16	x1	1/4
3	2010	640	28	x1	4/4
4	1925	604	22	x1	3/4
5	770	582	16	x1	2/4
6	770	582	16	x1	2/4
7	1925	90	16	x1	3/4

8	1925	135	16	x1	3/4
9	892	60	16	x2	3/4
10	892	88	16	x2	3/4
11	892	80	28	x1	3/4
12	892	80	28	x1	3/4
13	1832	100	16	x1	3/4
14	1925	100	16	x1	3/4

15	442	100	16	x2	2/4
16	636	564	16	x1	2/4
17	636	564	16	x1	2/4
18	797	614	3	x2	4/4
19	797	706	3	x1	4/4
20	692	573	16	x2	2/4
21	599	573	16	x4	1/4

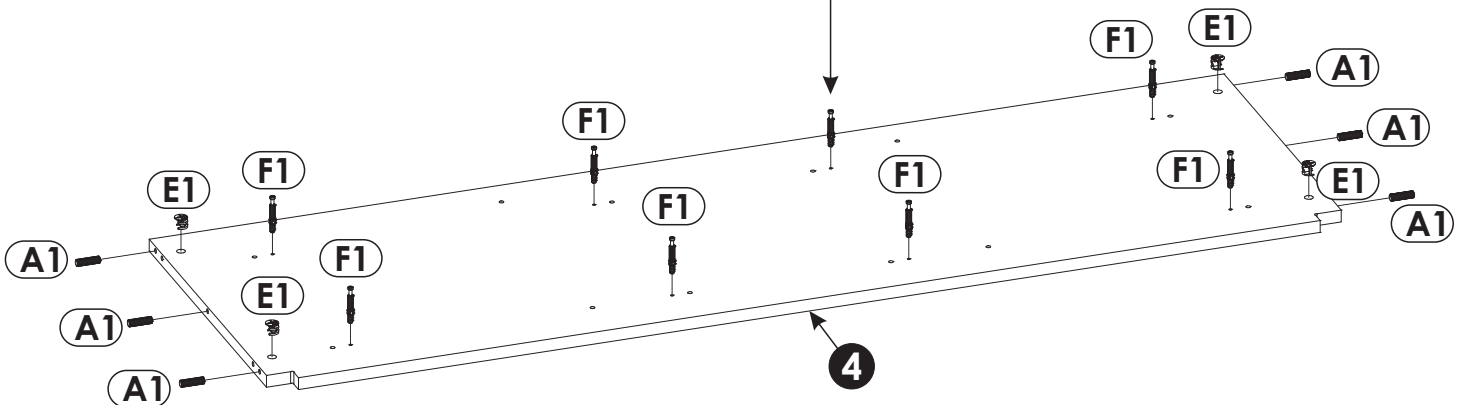
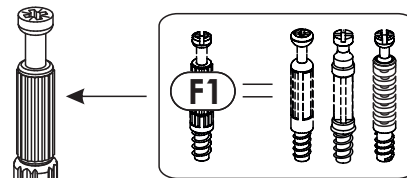
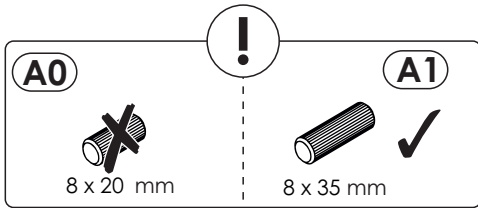
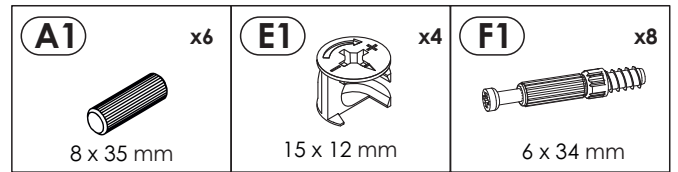
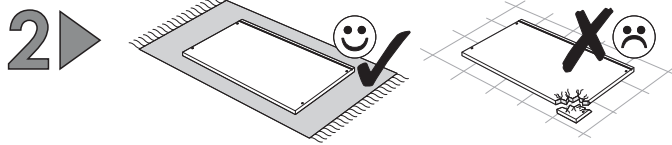
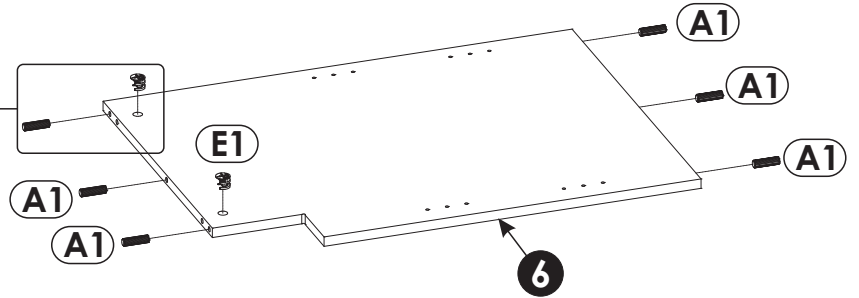
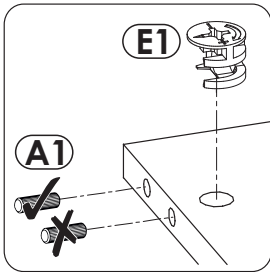
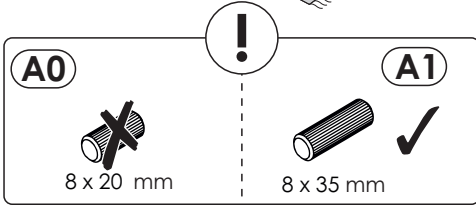
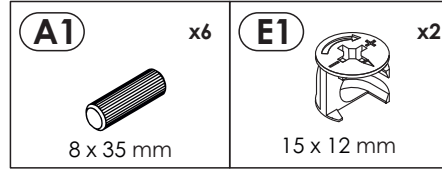
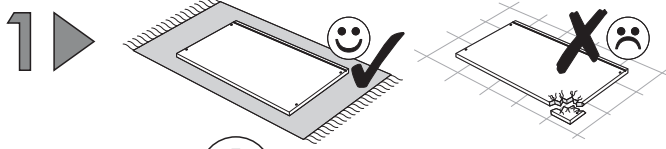

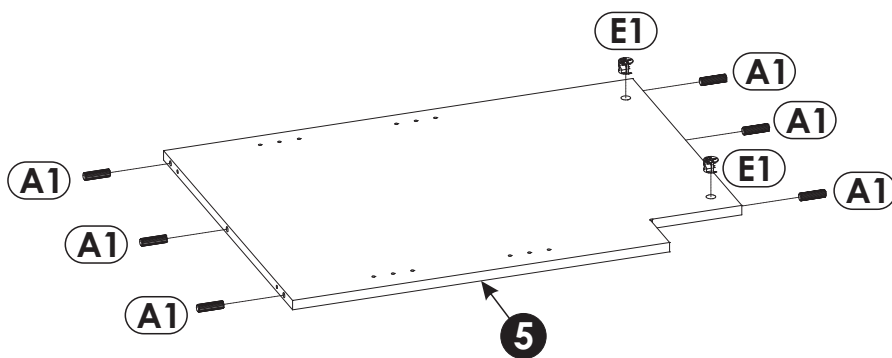
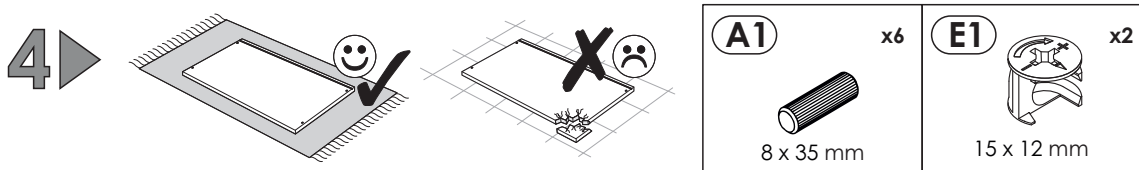
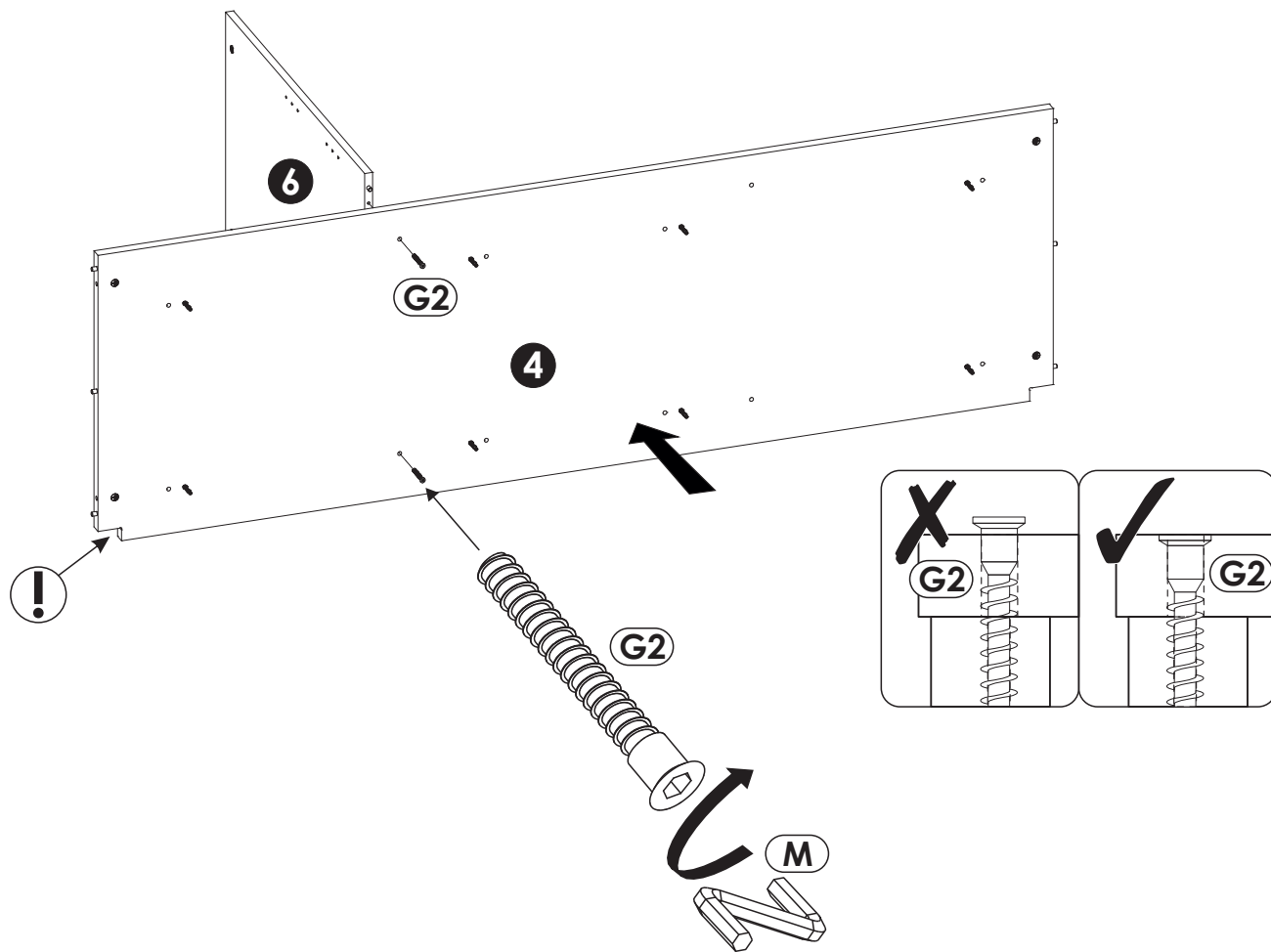
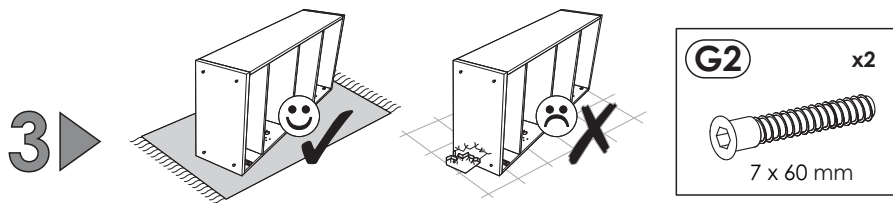

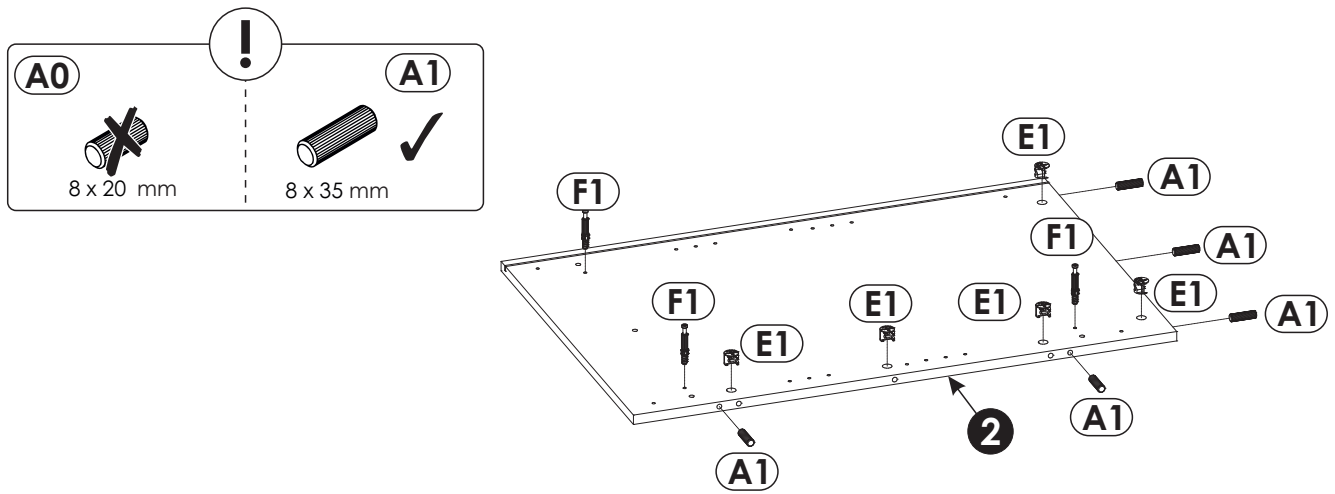
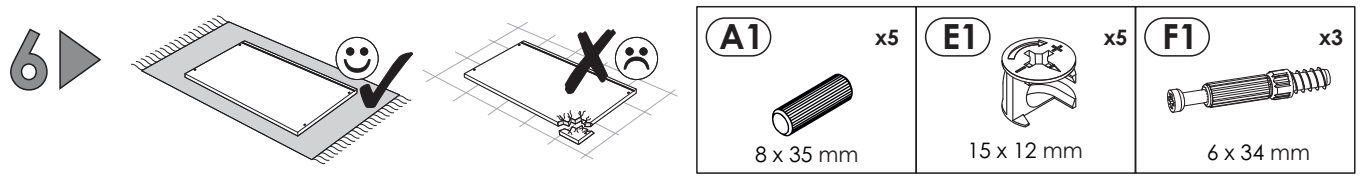
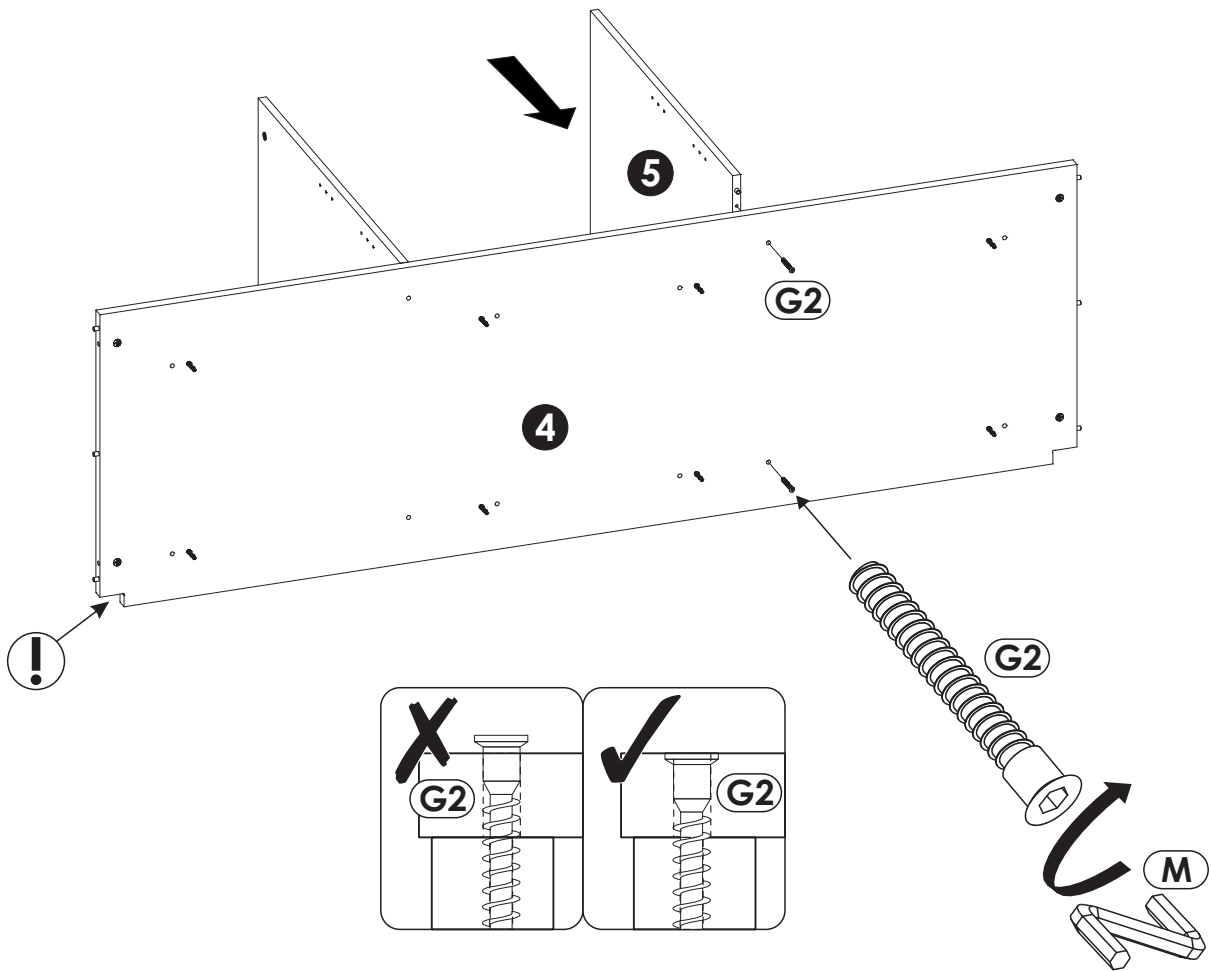
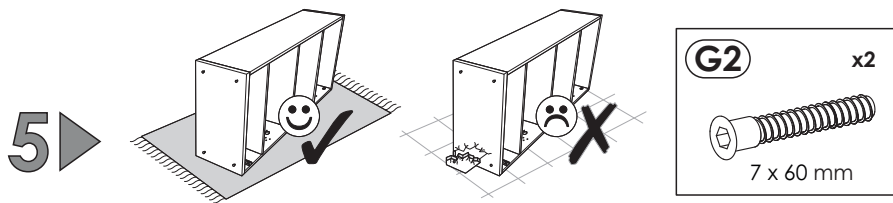

7 ▶

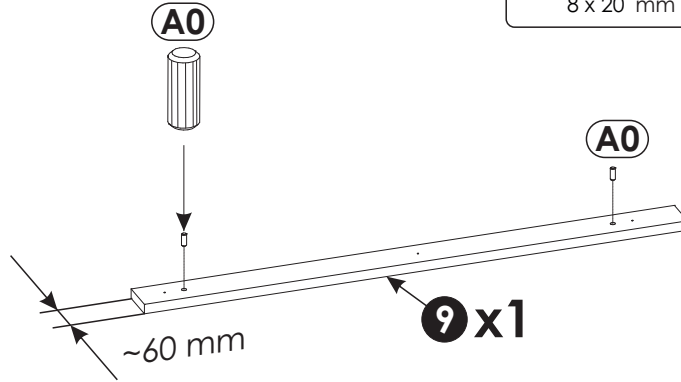
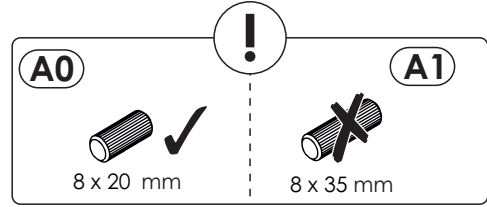
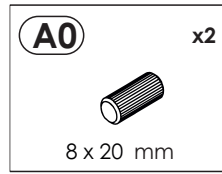
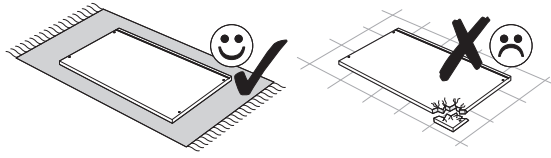

8 ▶

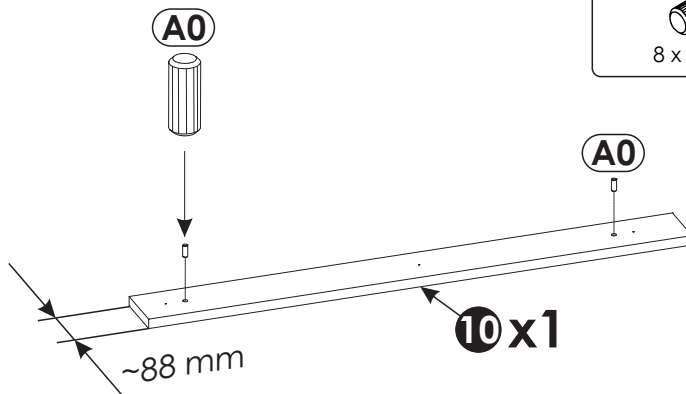
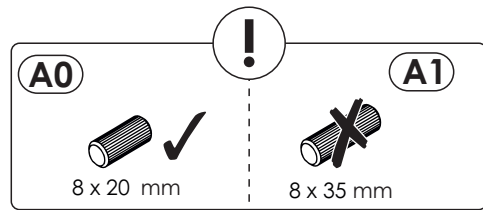
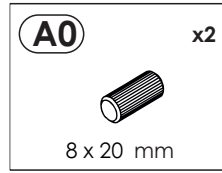
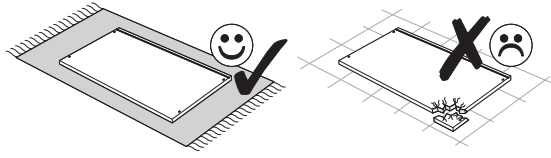

9 ▶

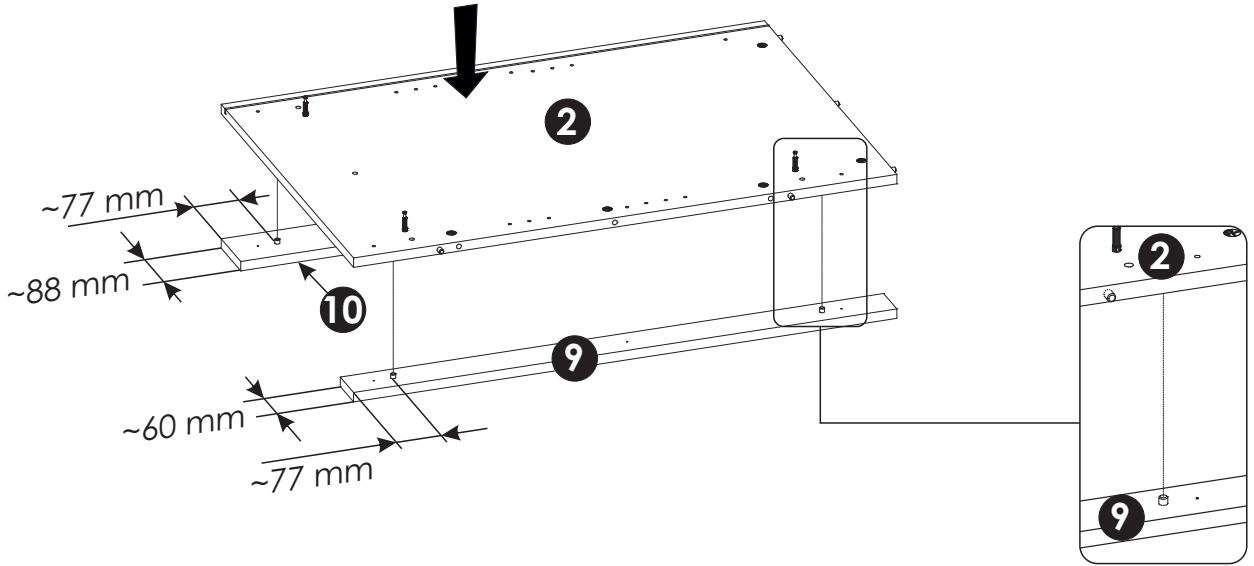
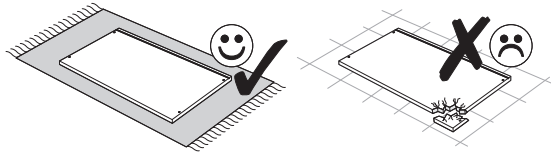

10 ▶

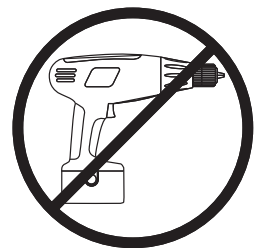
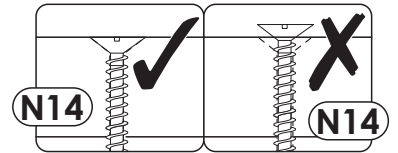
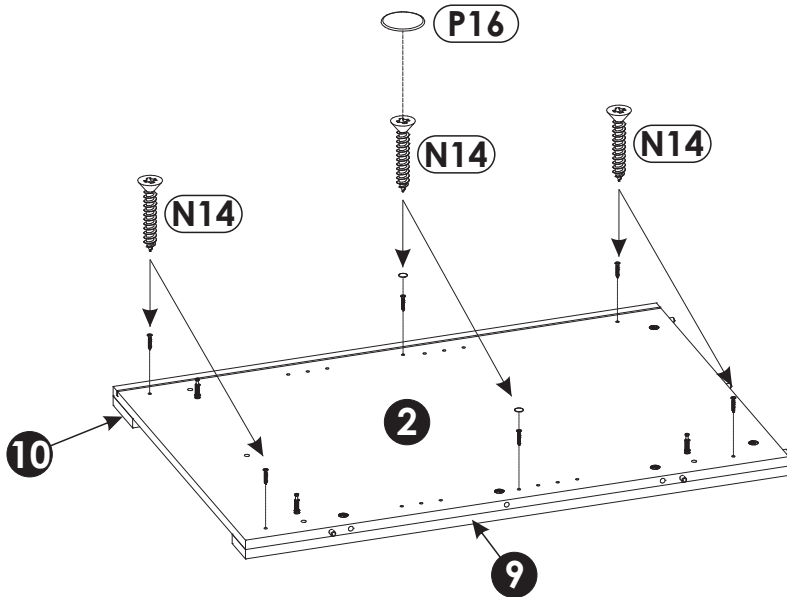
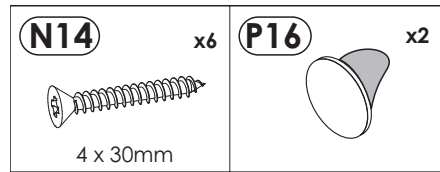
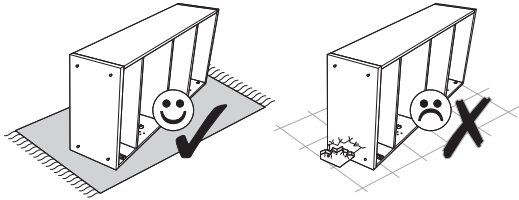

11 ▶

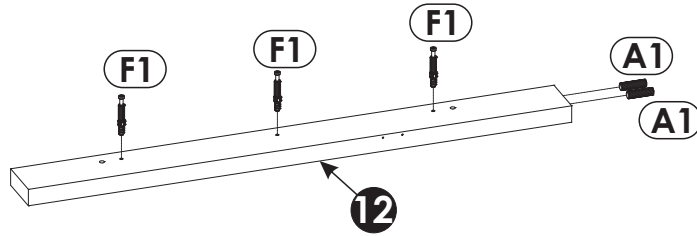
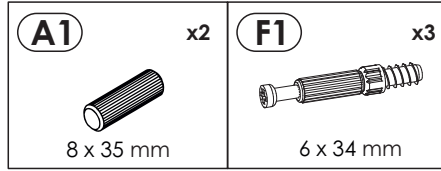
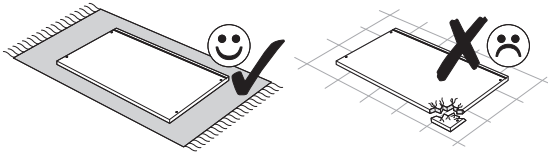

12 ▶

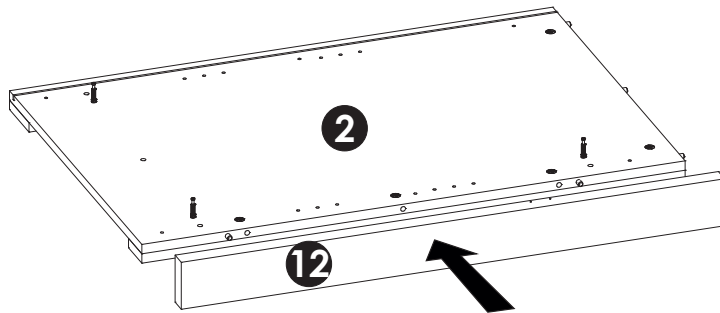
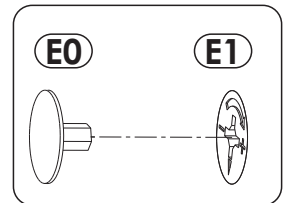
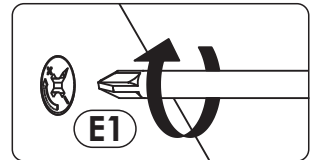
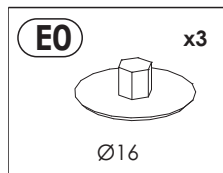
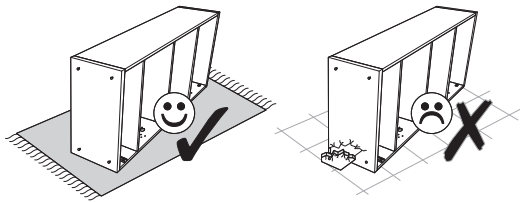

13 ▶

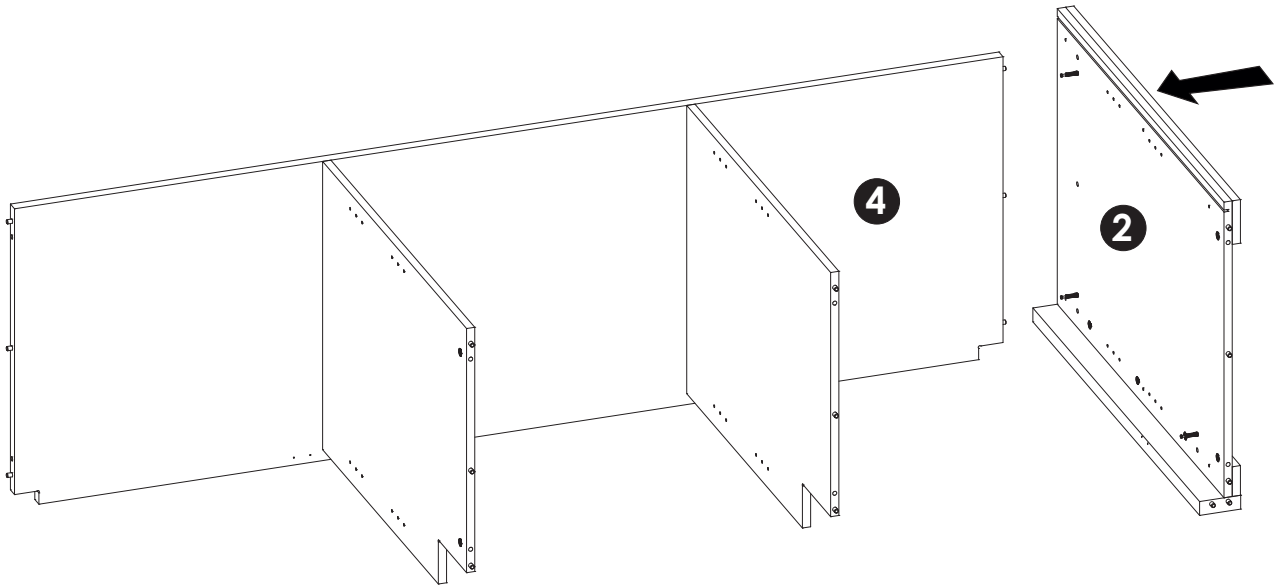
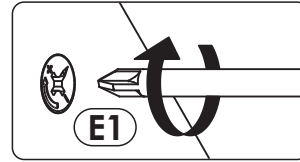
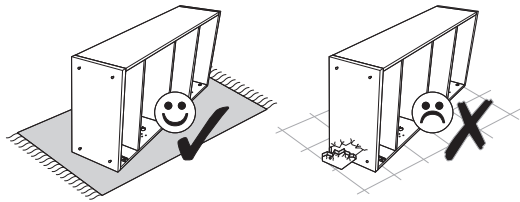

14.a ▶

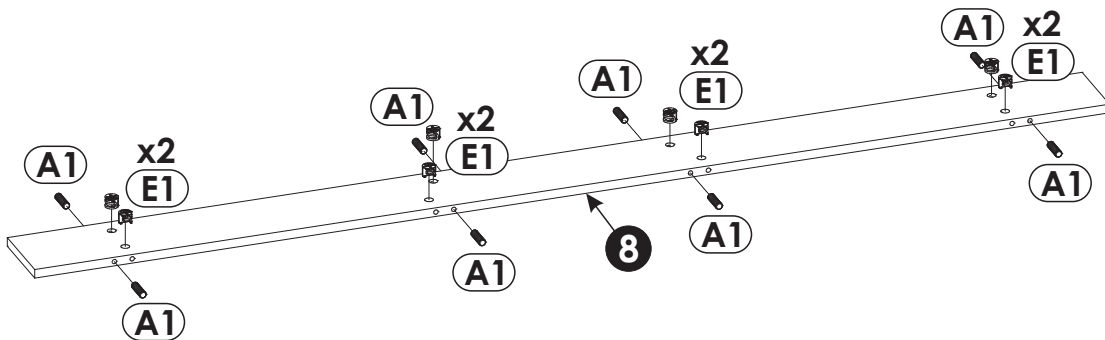
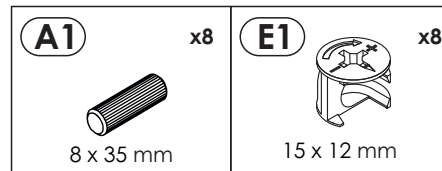
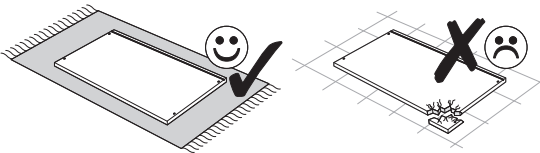

14.b ▶

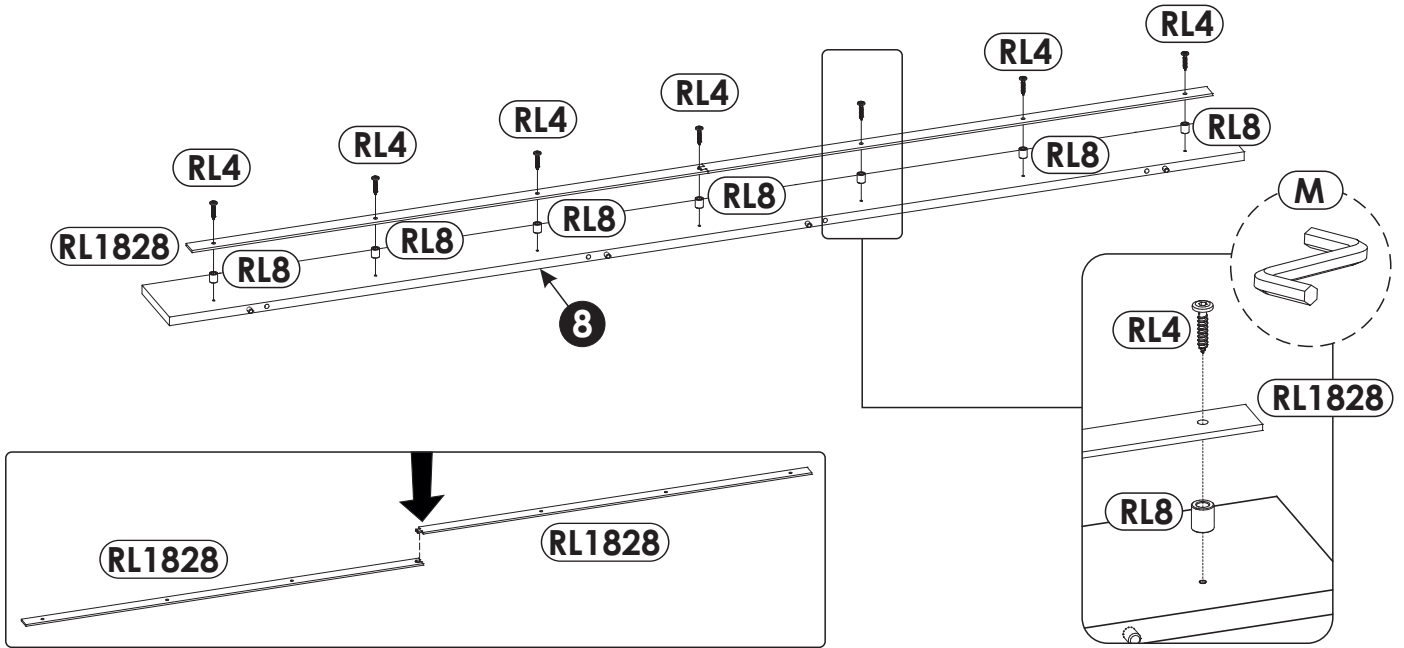
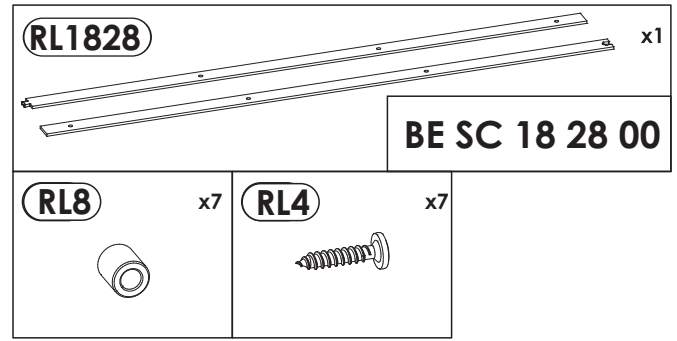
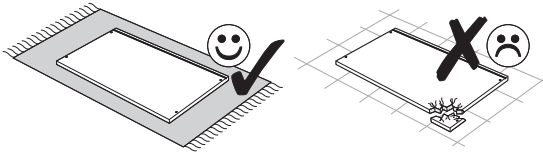

15 ▶

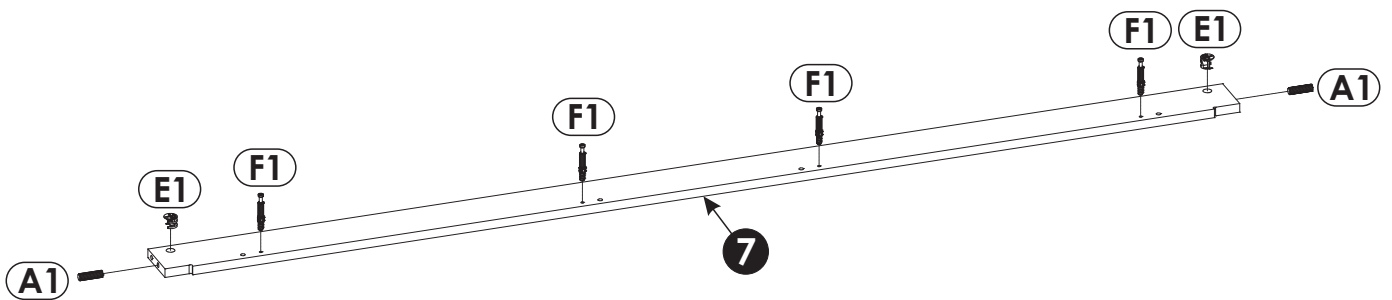
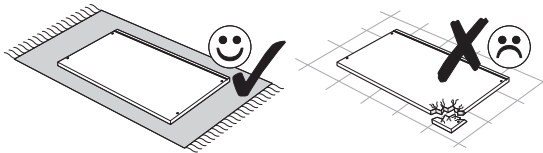

16 ▶

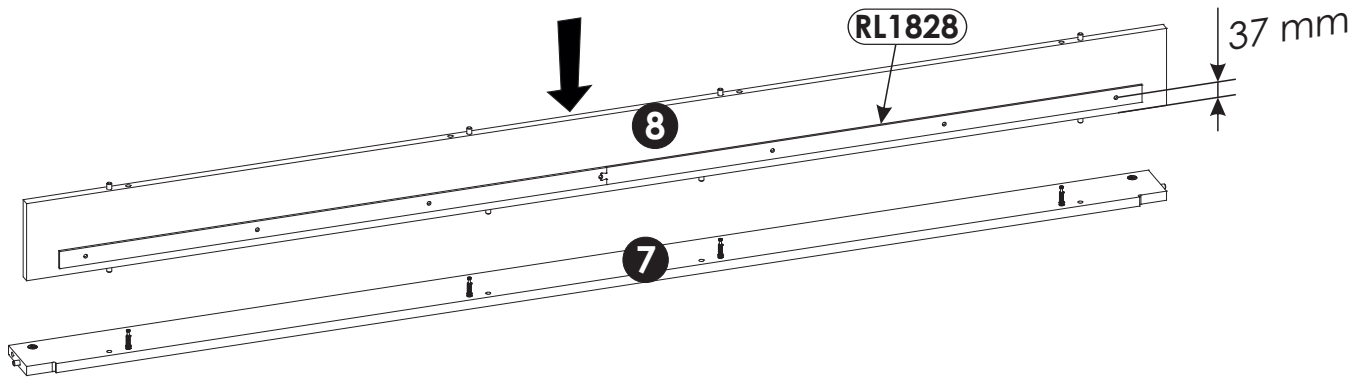
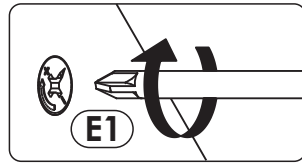
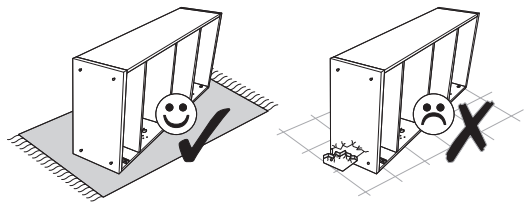

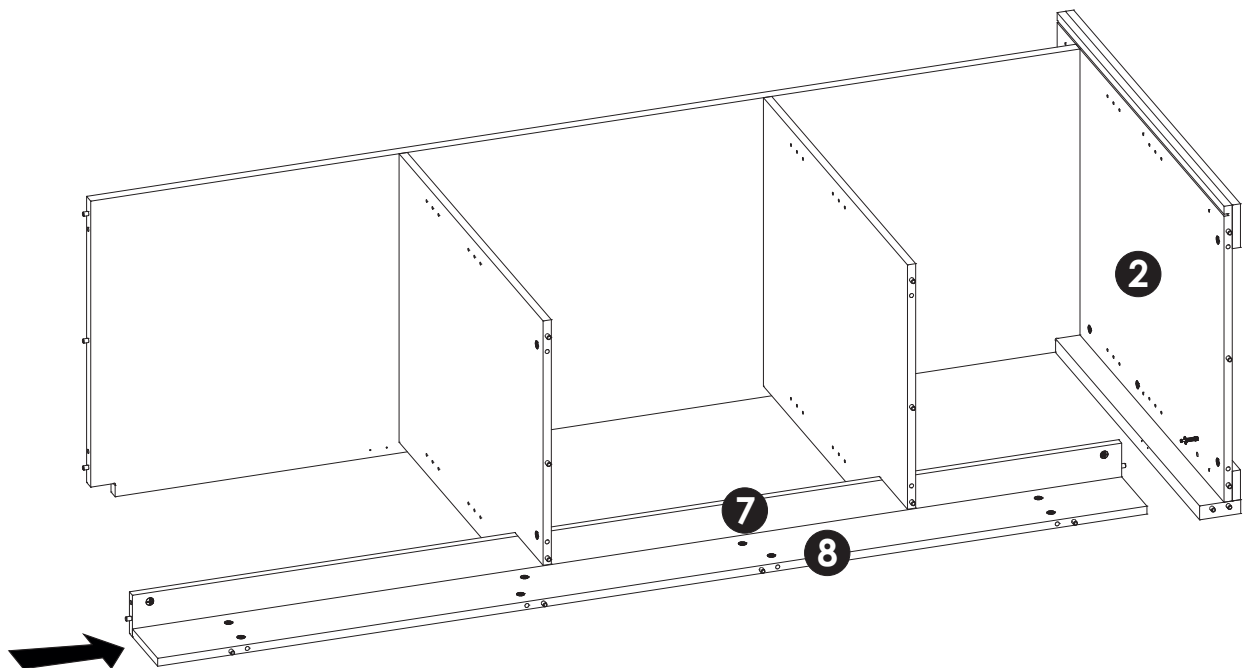
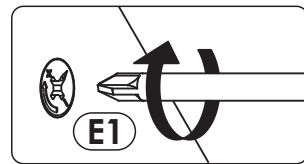
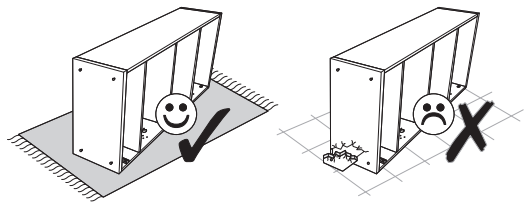

17 ▶

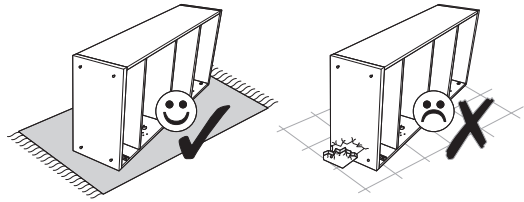

18▶



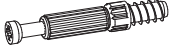

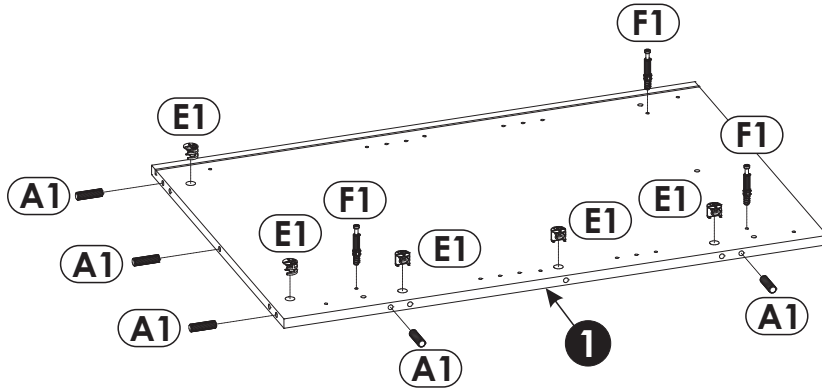
A1	x5	E1	x5	F1	x3
					
8 x 35 mm		15 x 12 mm		6 x 34 mm	

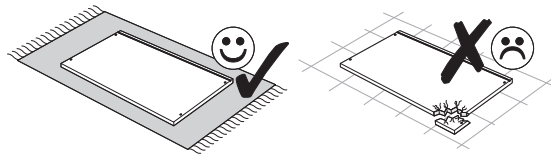

19▶



A0	x2
	
8 x 20 mm	

A0	!	A1
		
8 x 20 mm ✓		8 x 35 mm ✗

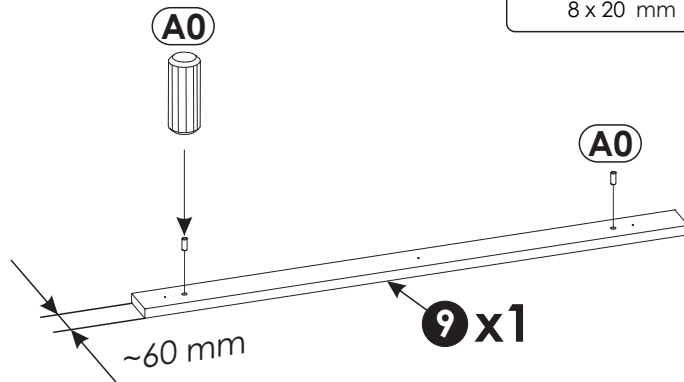

20 ▶

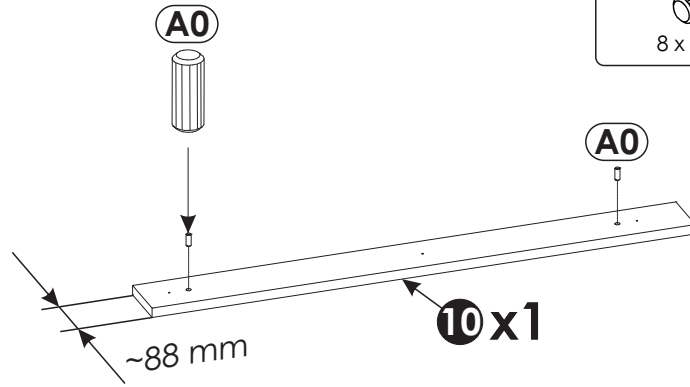
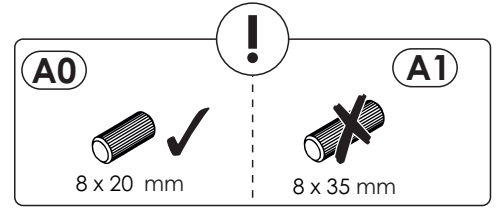
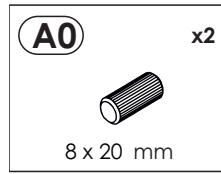
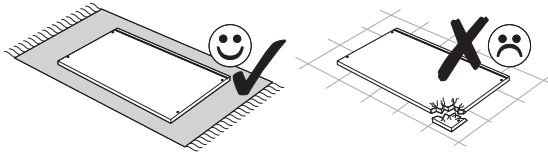

21 ▶

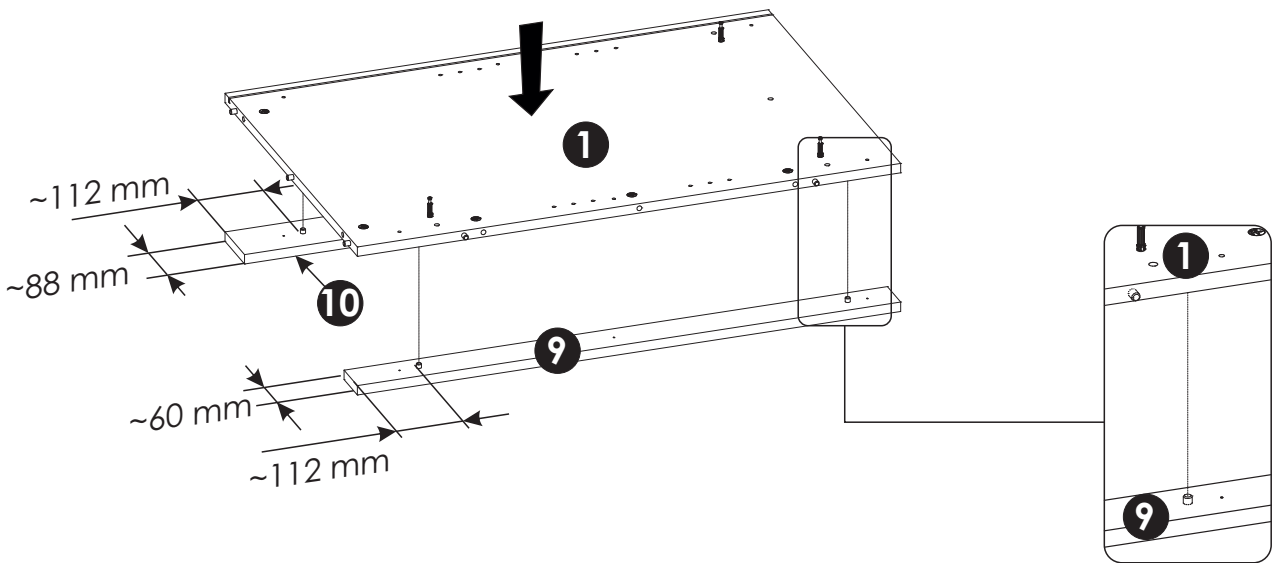
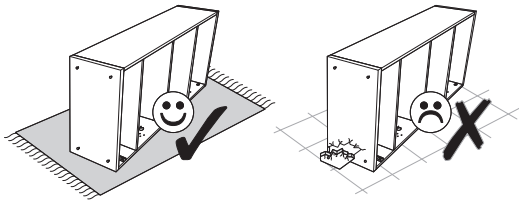

22 ▶

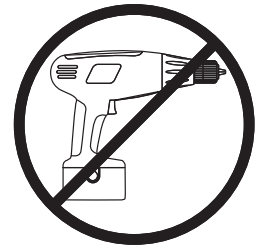
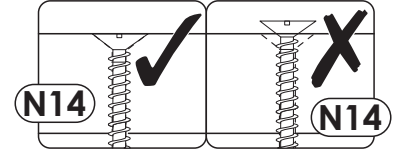
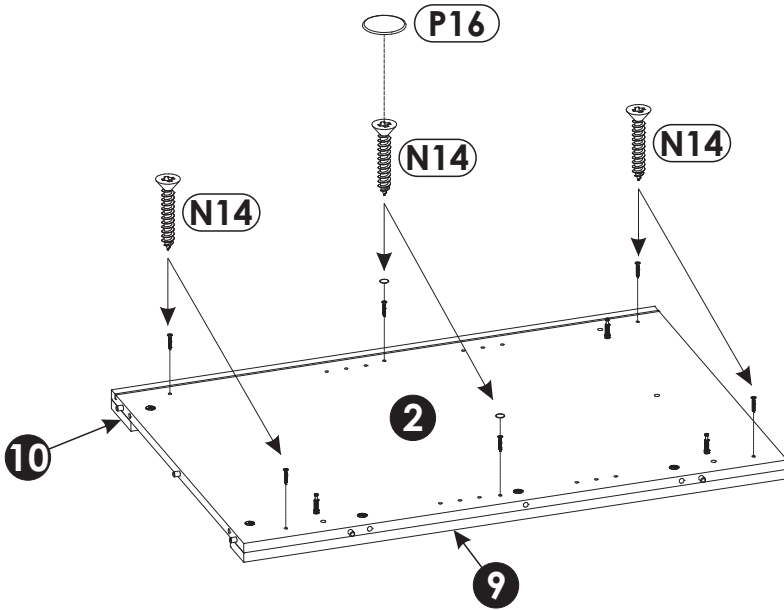
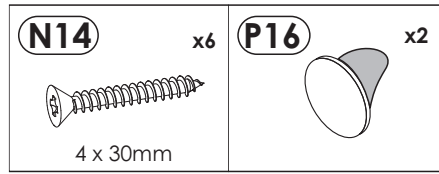
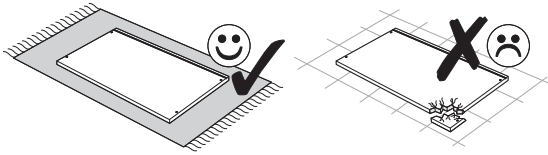

23 ▶

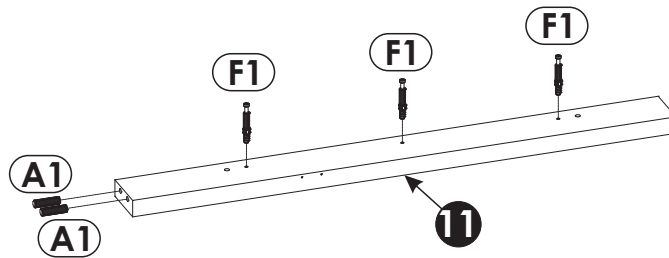
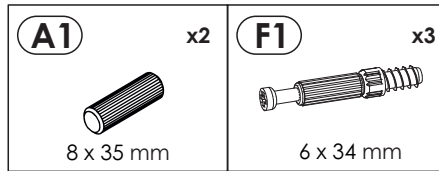
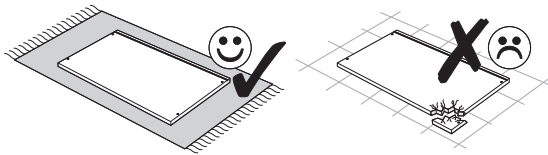

24 ▶

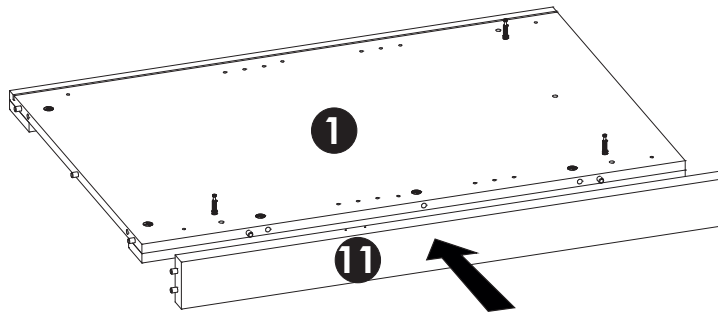
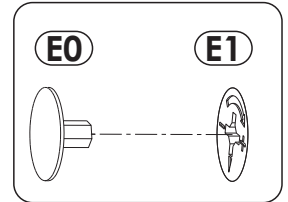
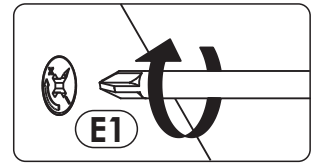
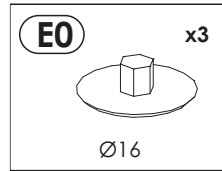
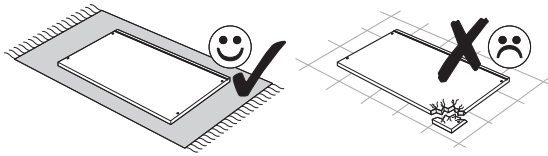

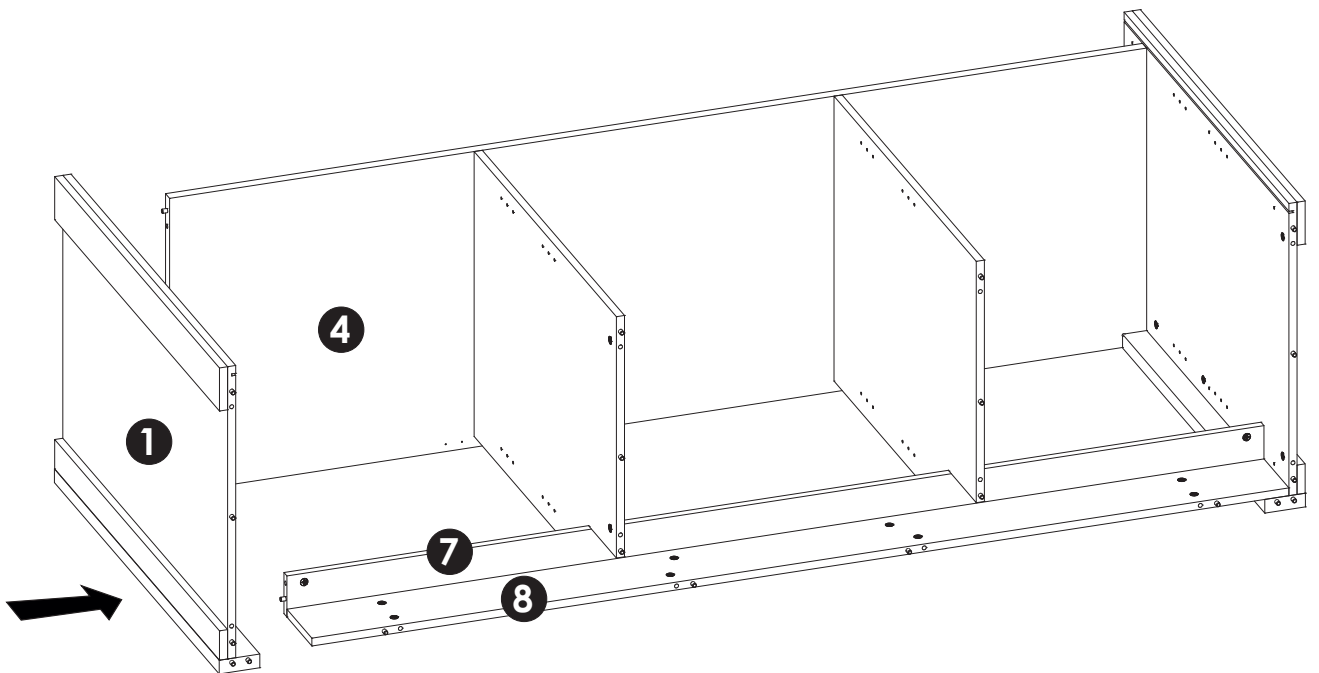
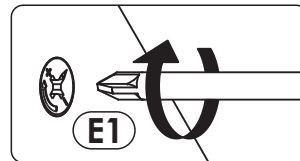
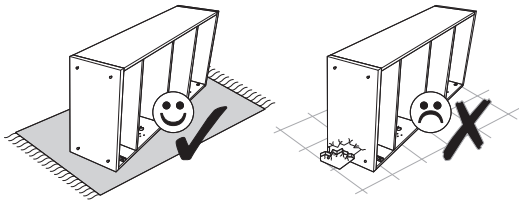

25 ▶

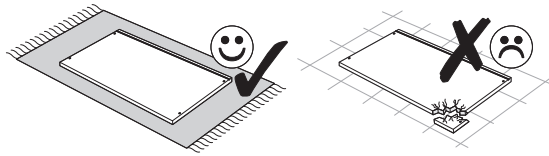

26 ▶



A1	x8	E1	x4
			
8 x 35 mm		15 x 12 mm	

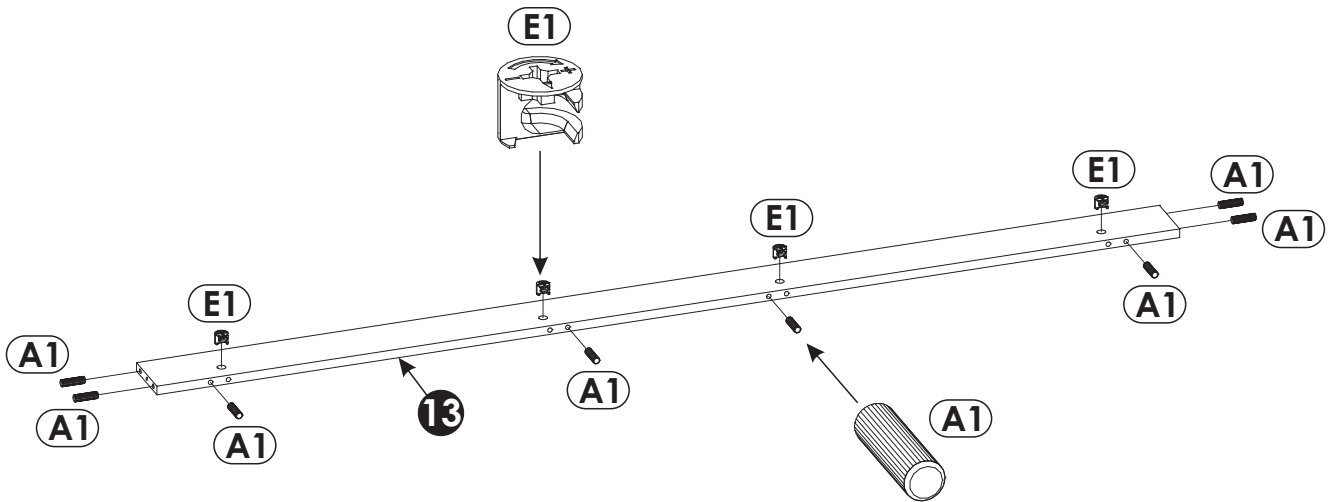

27 ▶

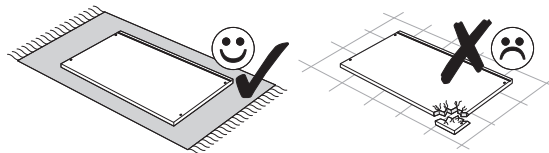

A1	x4
	
8 x 35 mm	

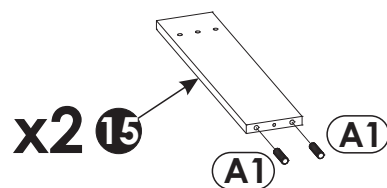

28 ▶

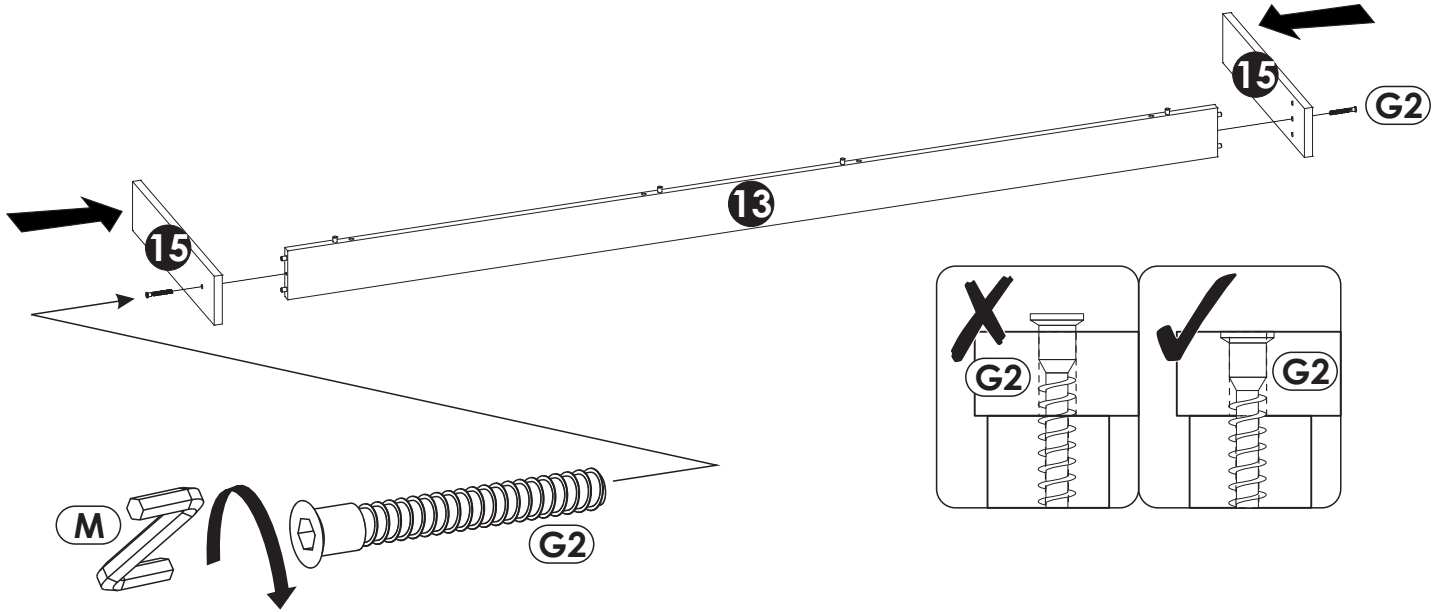
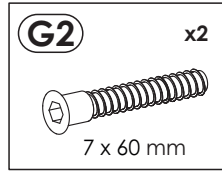
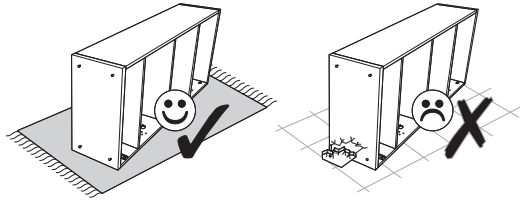

29 ▶

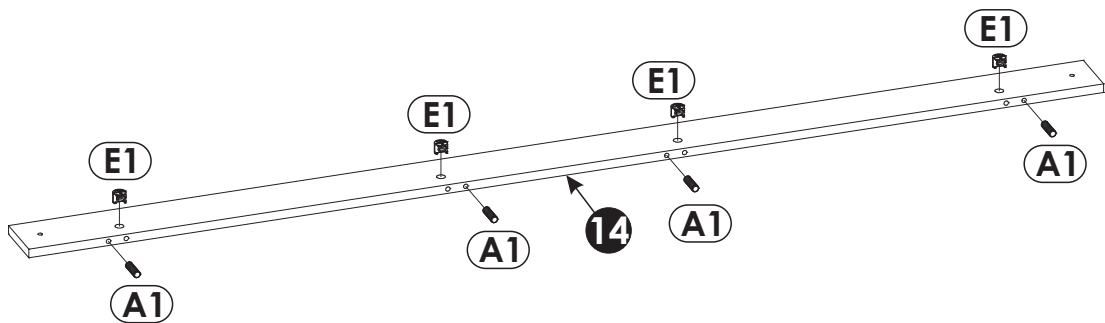
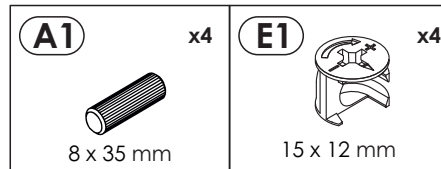
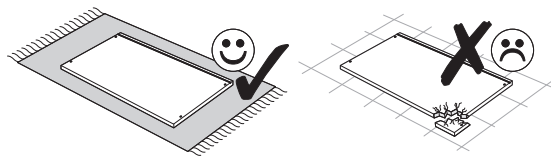

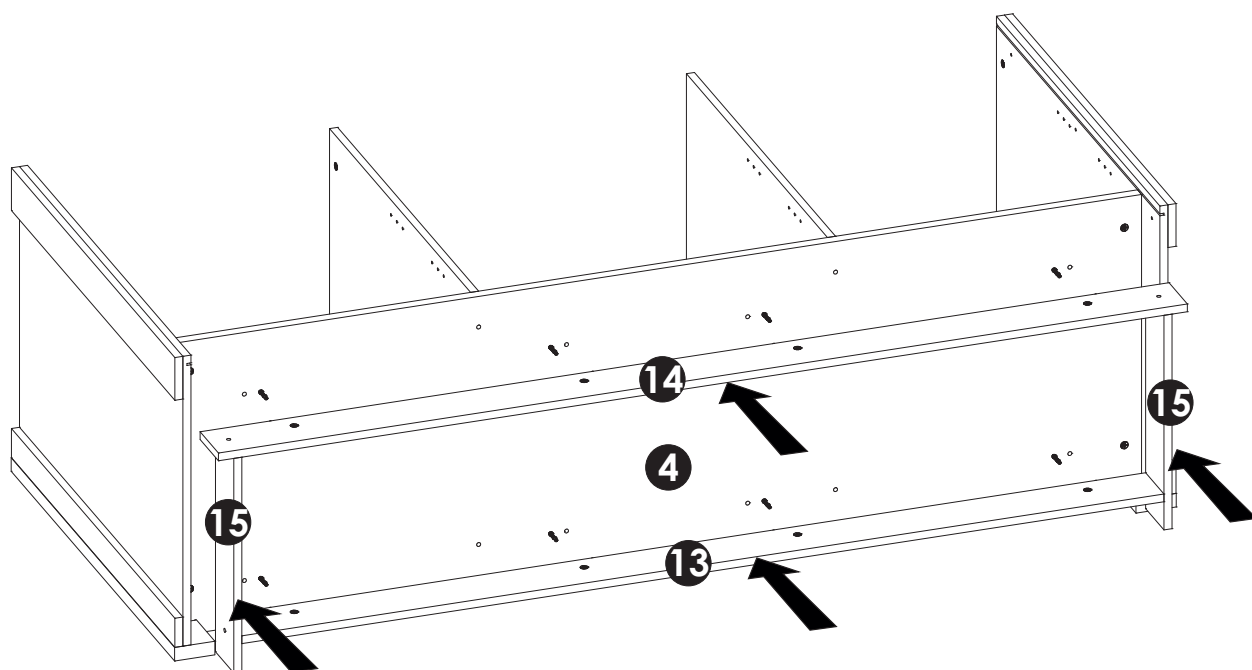
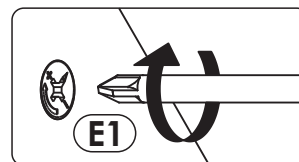
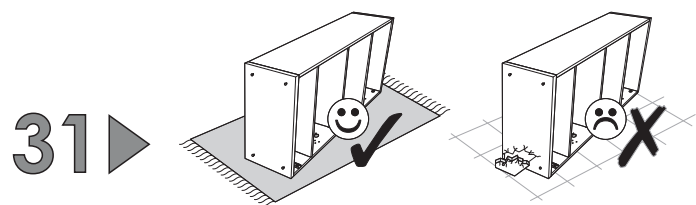
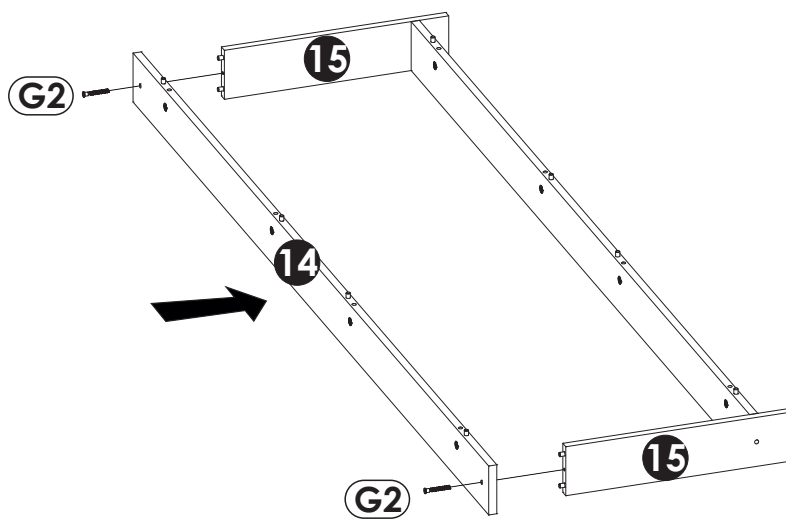
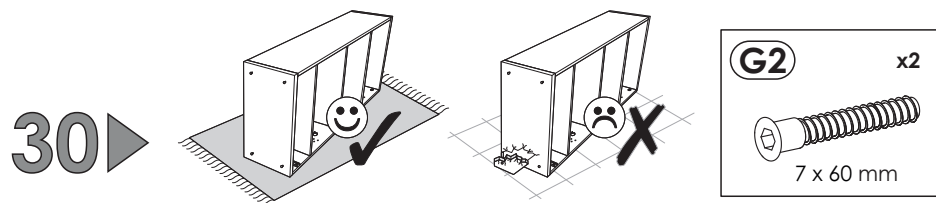

32 ▶

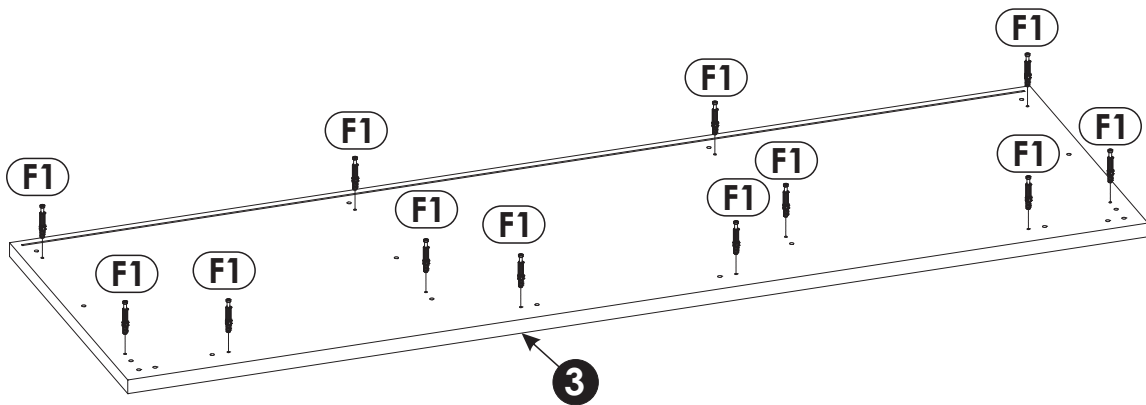
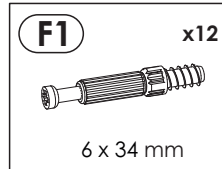
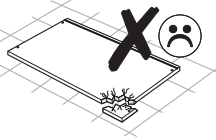
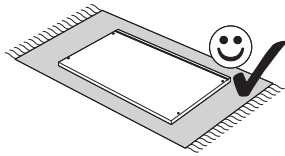

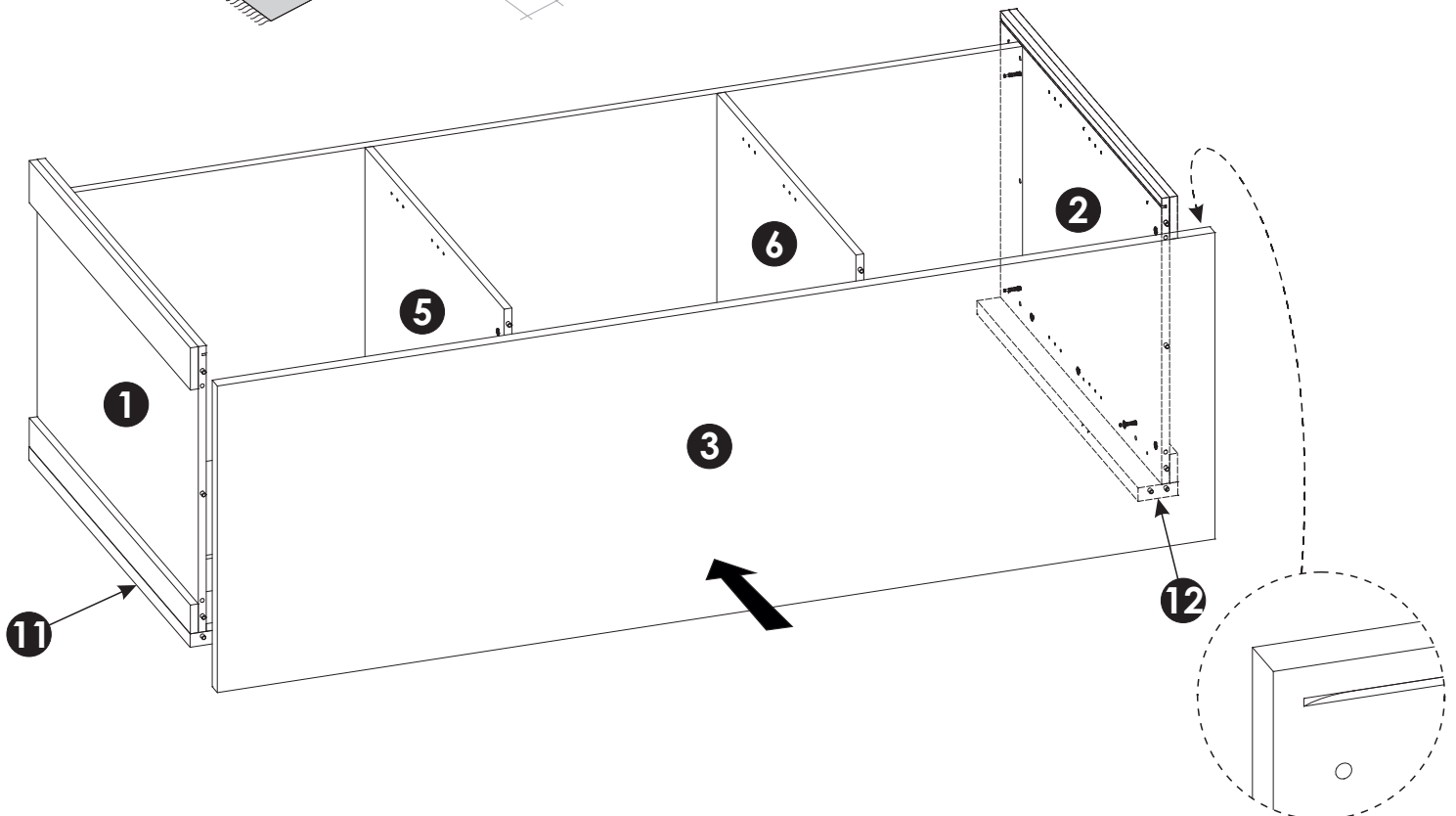
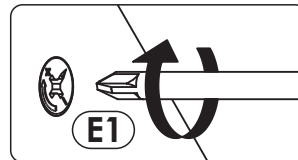
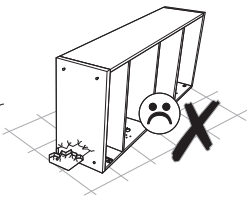
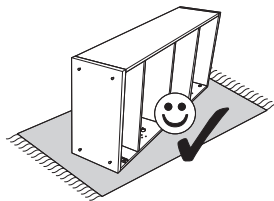

33 ▶

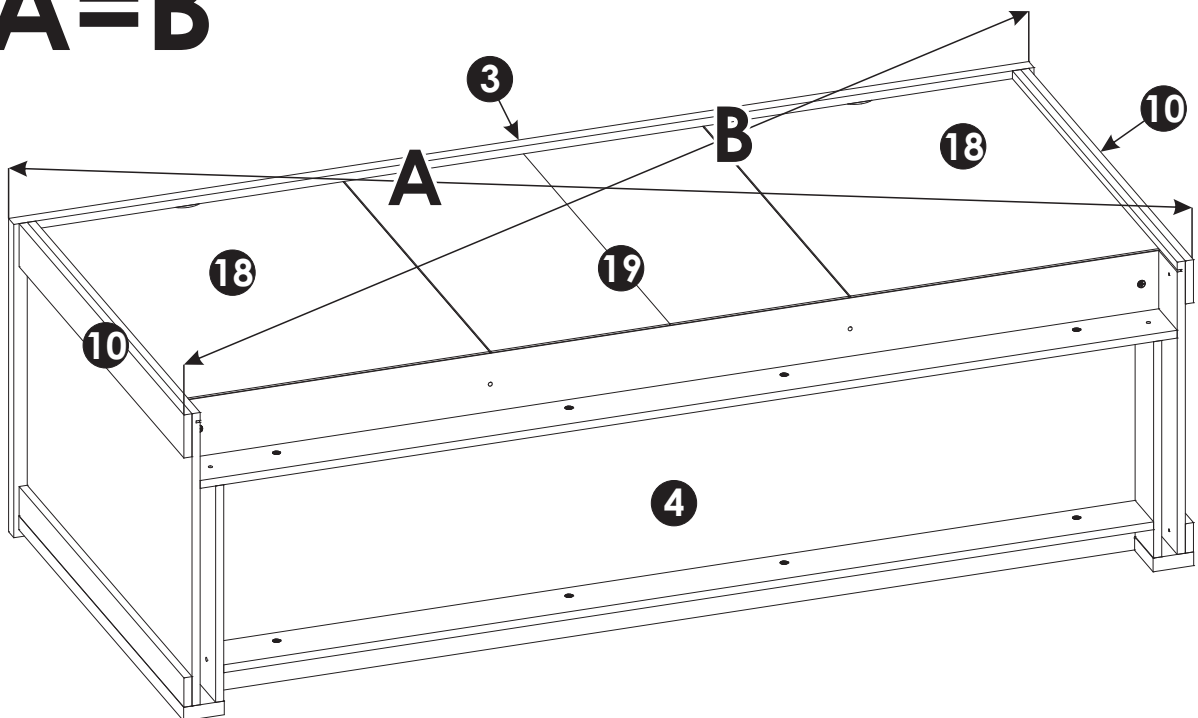
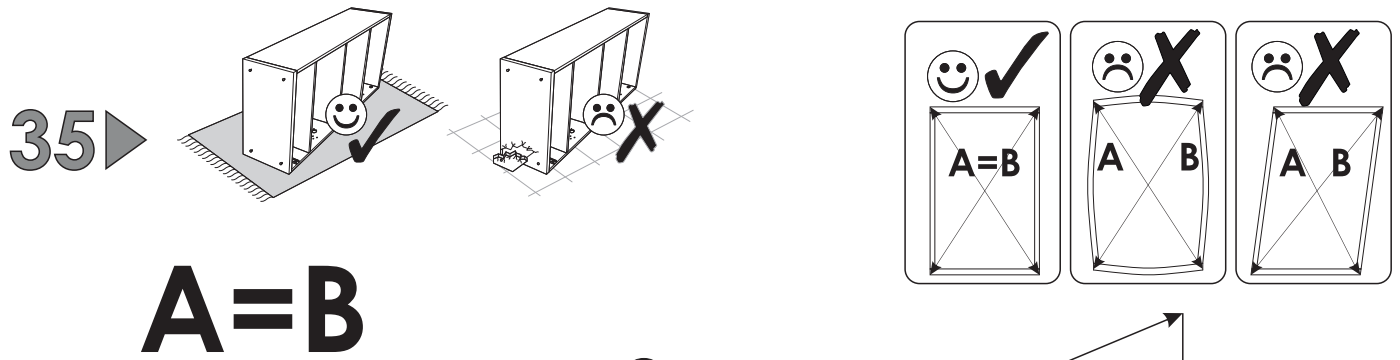
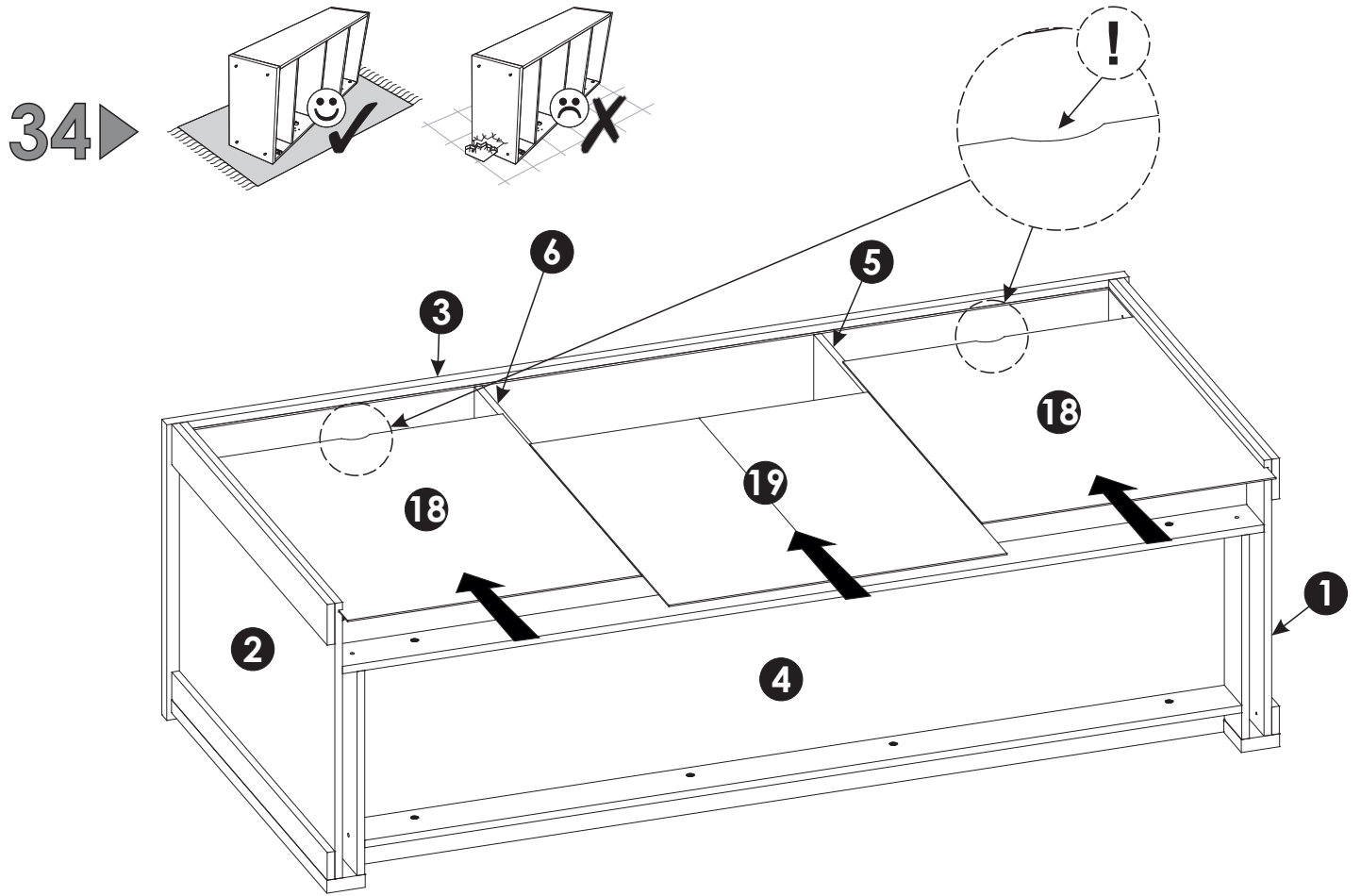

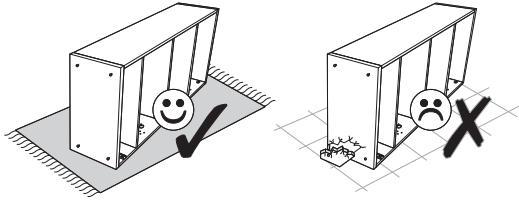

36 ▶

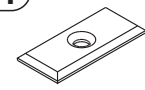
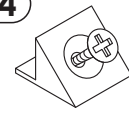

N1 x25 3 X 16 mm 	R1 x10 	R4 x10 
--	---	---

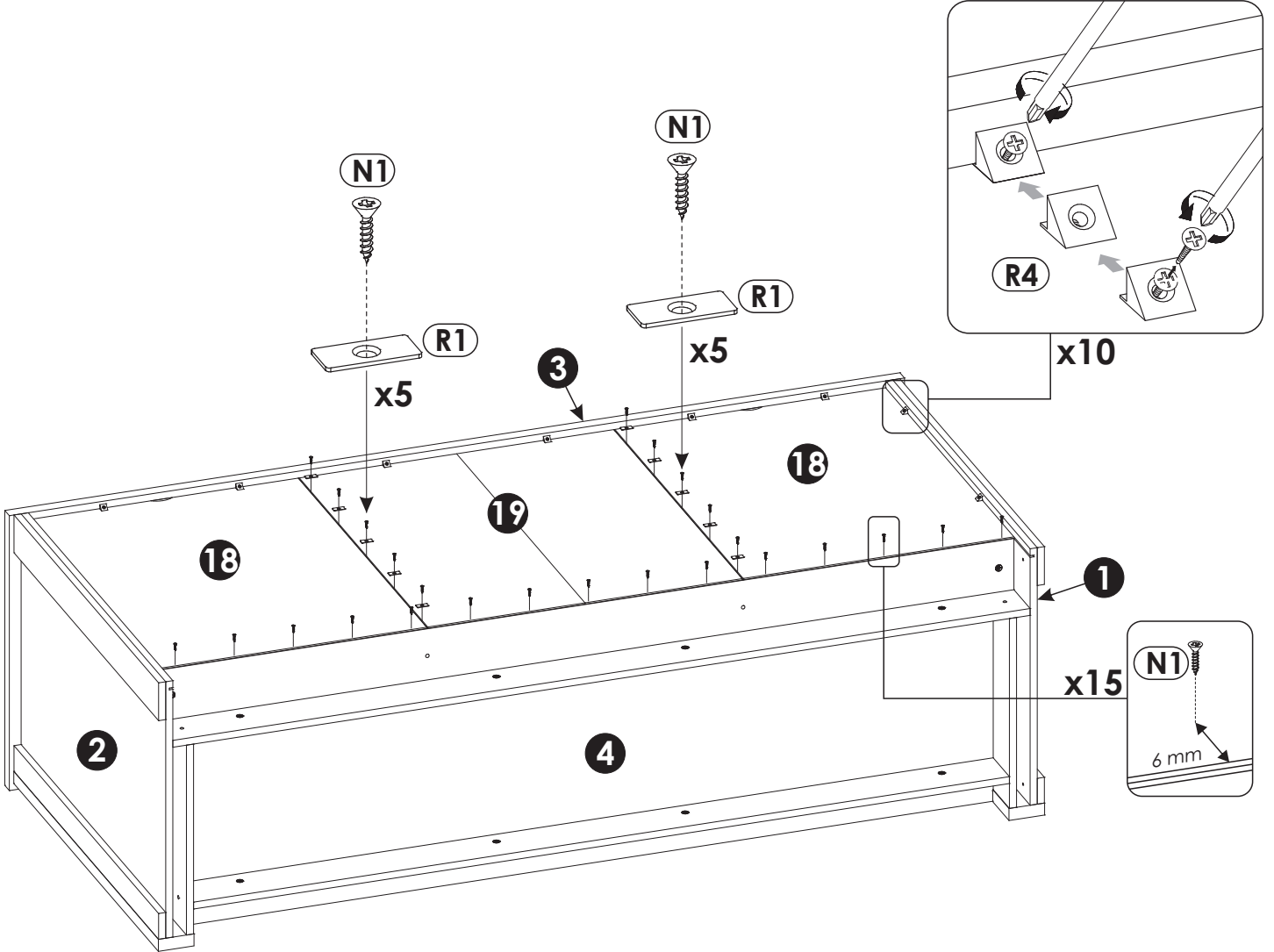

37▶▶

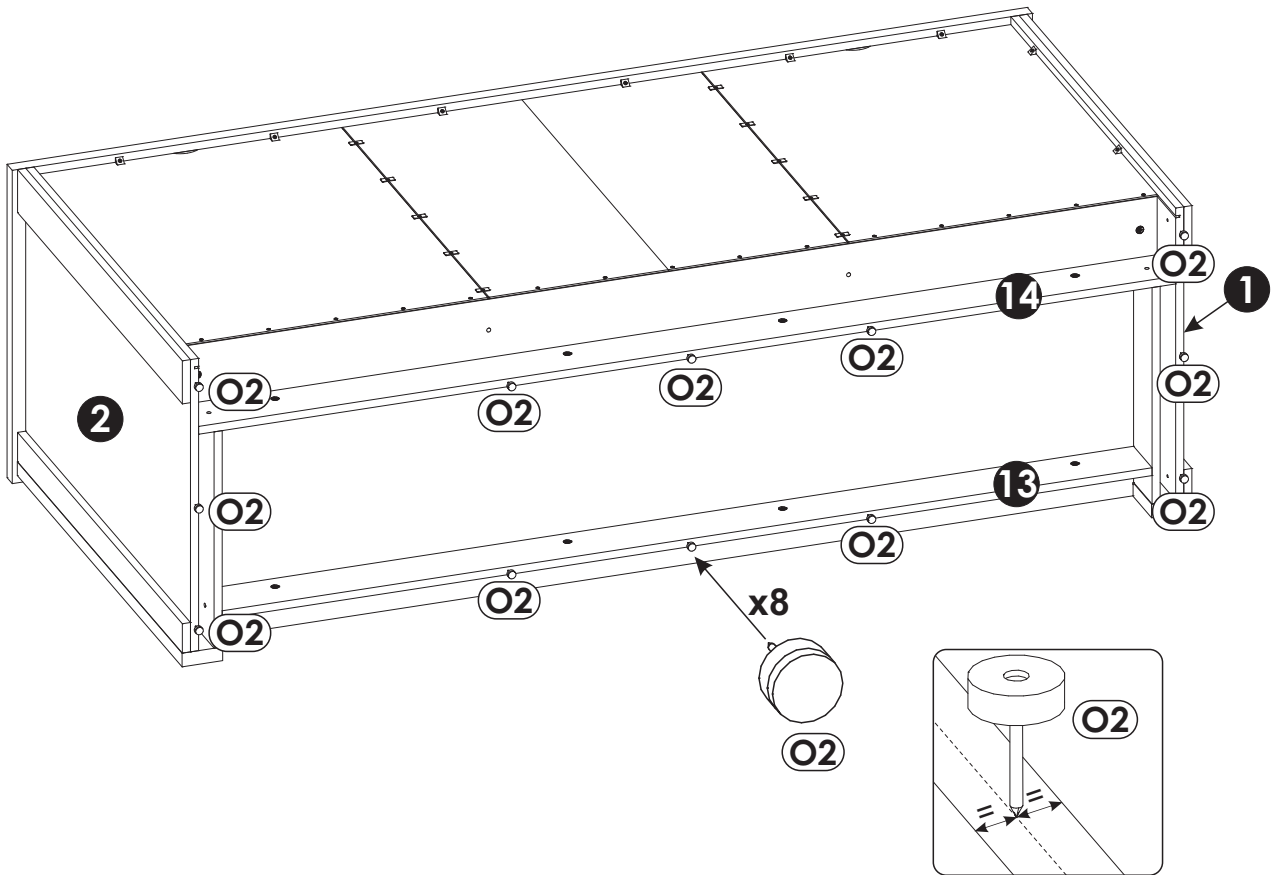
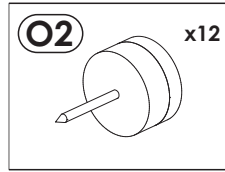
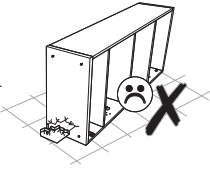
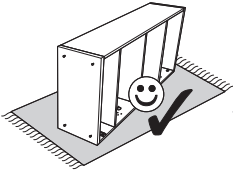

38 ▶

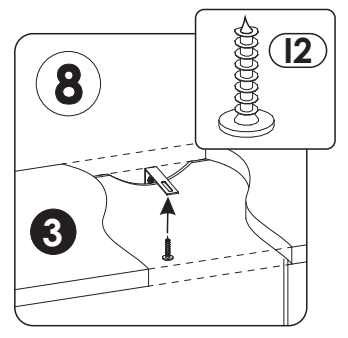
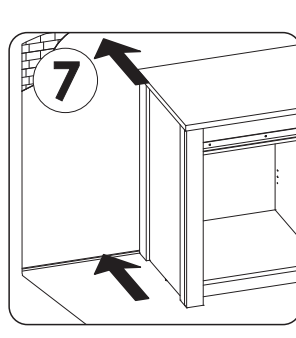
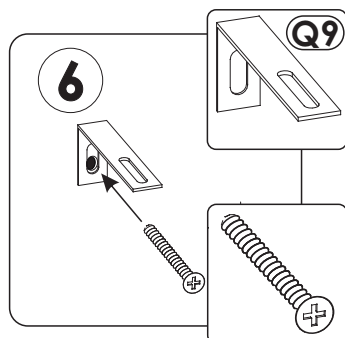
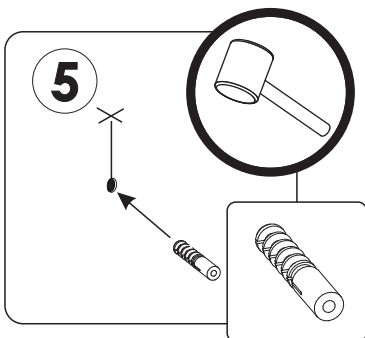
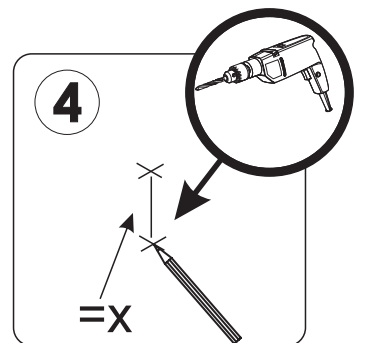
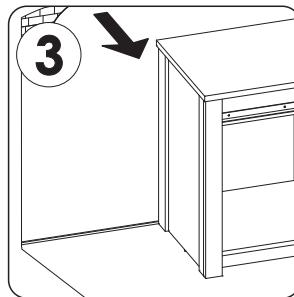
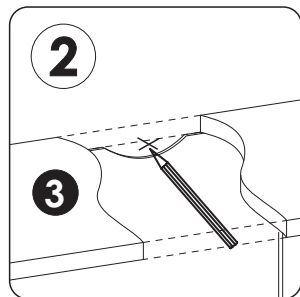
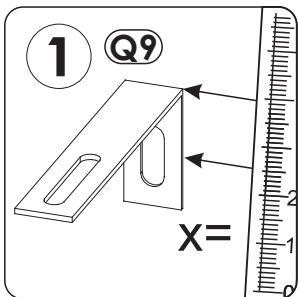
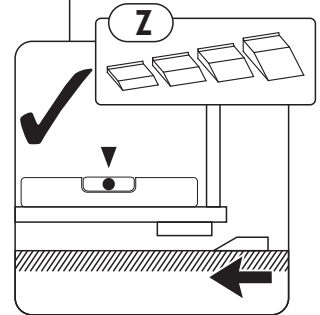
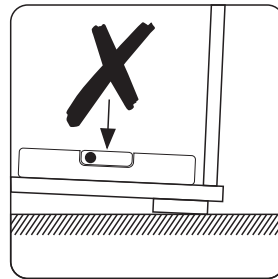
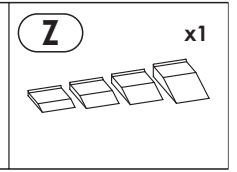
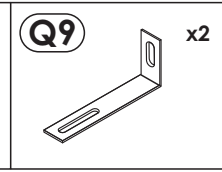
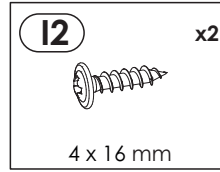
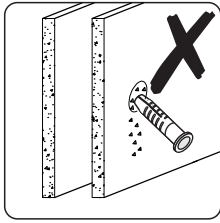
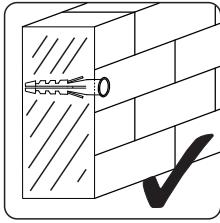

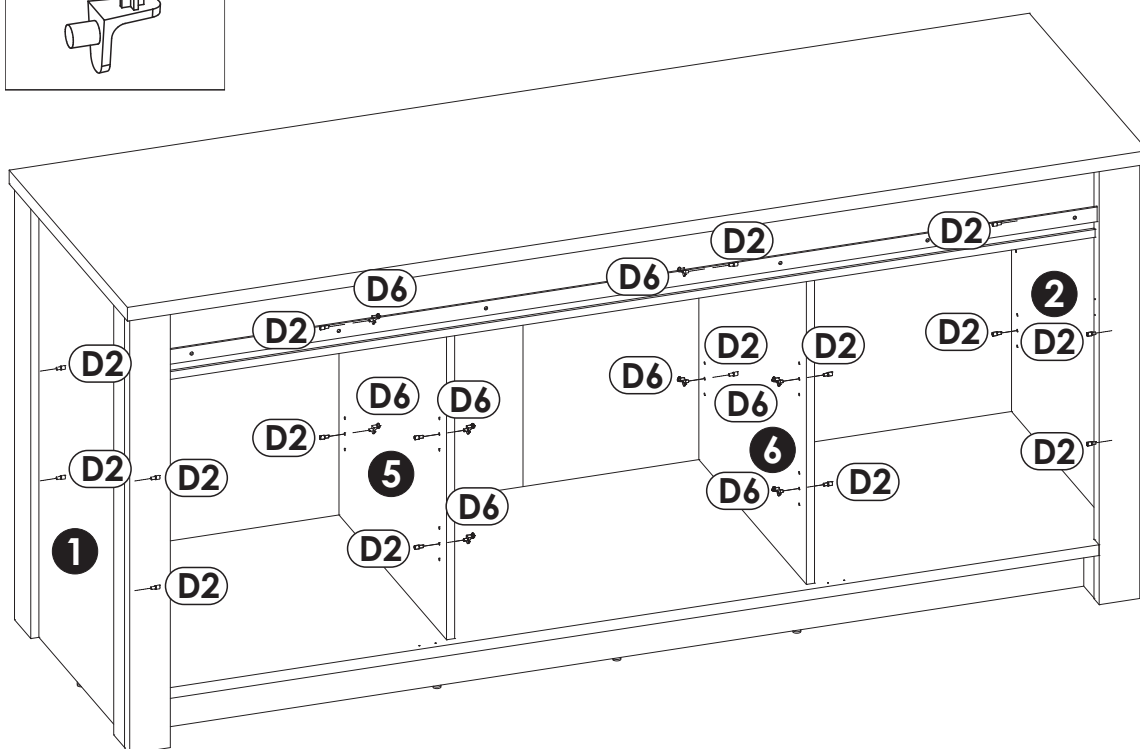
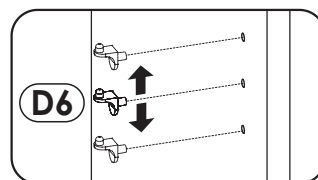
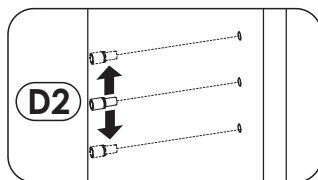
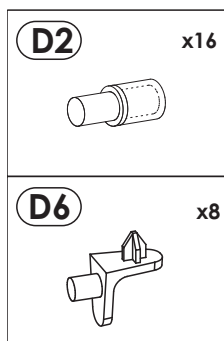

39 ▶

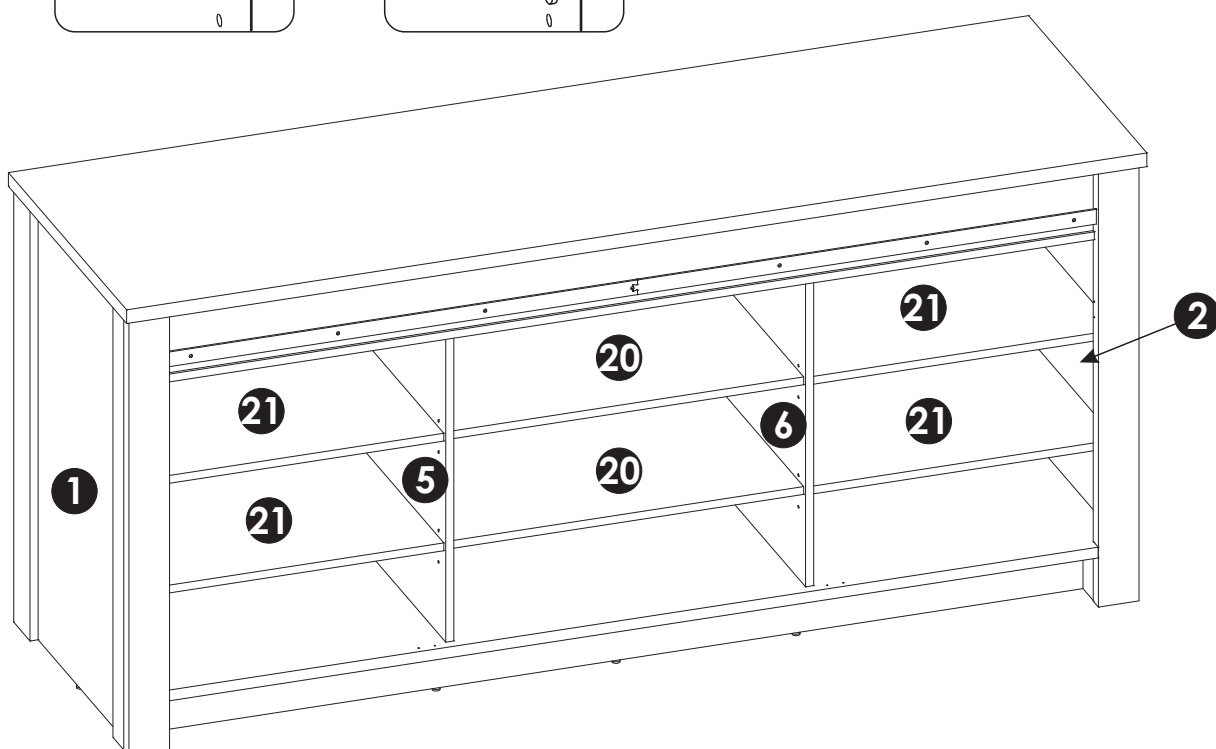
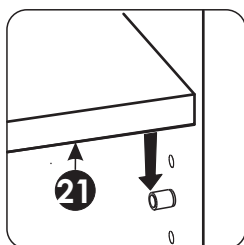

40 ▶

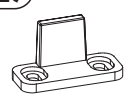

41 ▶

I0 x4  3 x 13 mm	R10 x2 	RL2 x4 	RL7 x2 
---	---	---	--

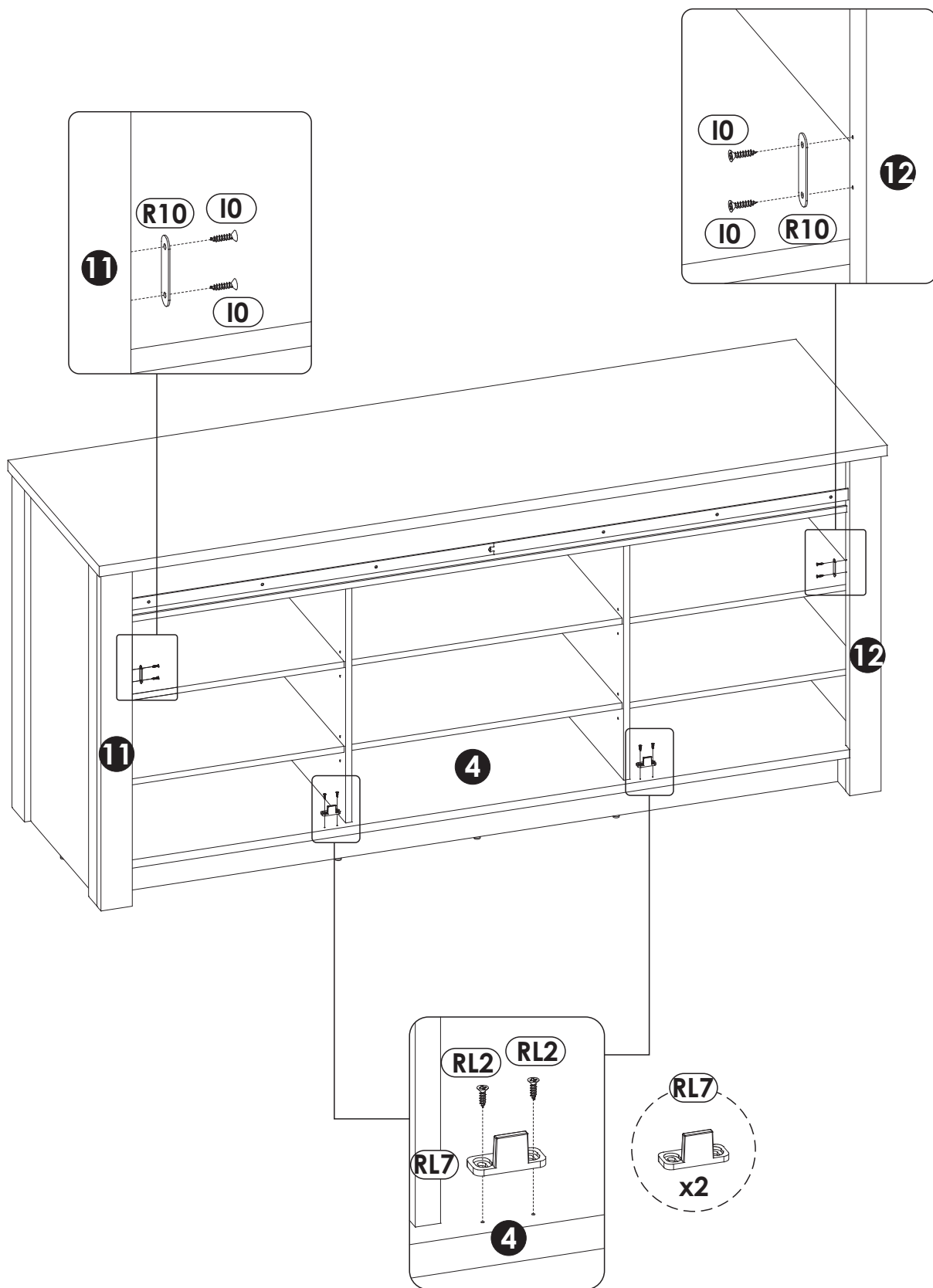

42 ▶

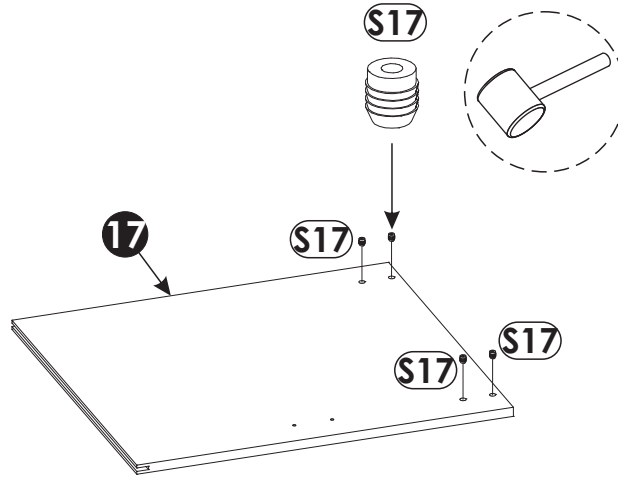
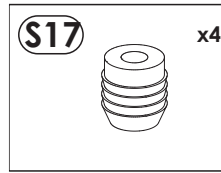
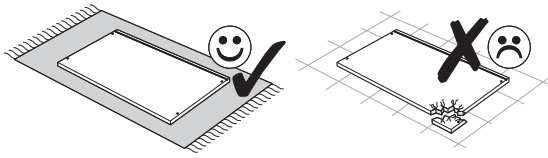

43 ▶

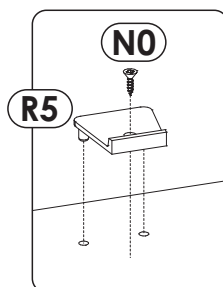
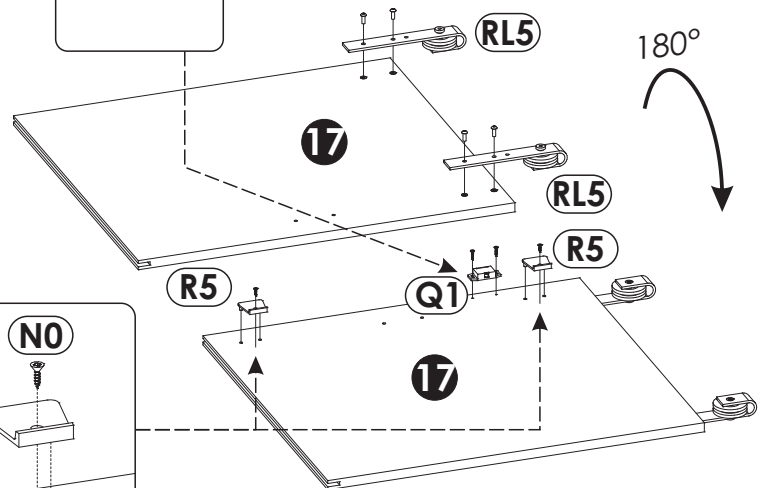
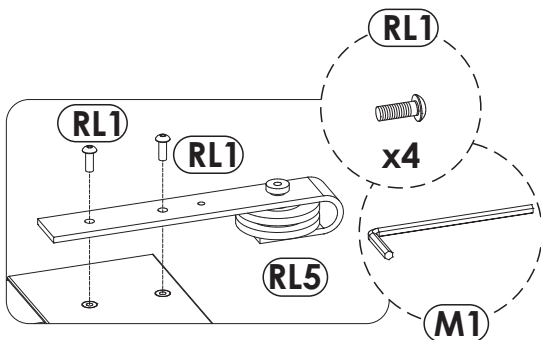
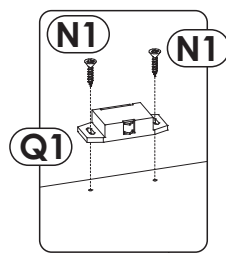
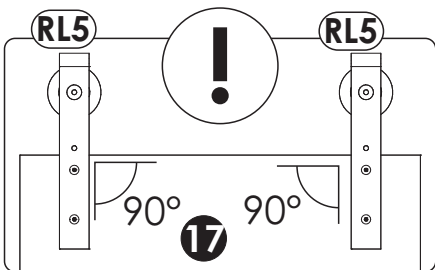
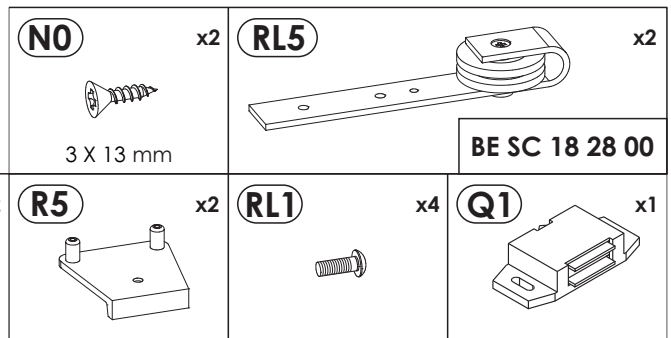
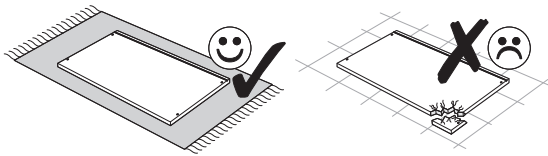

44▶

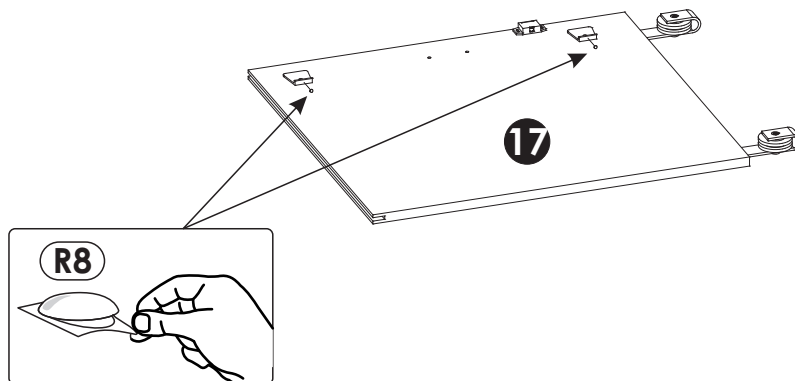
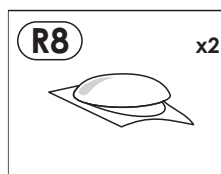
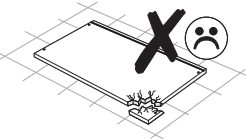
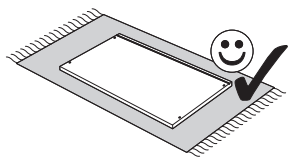

45▶

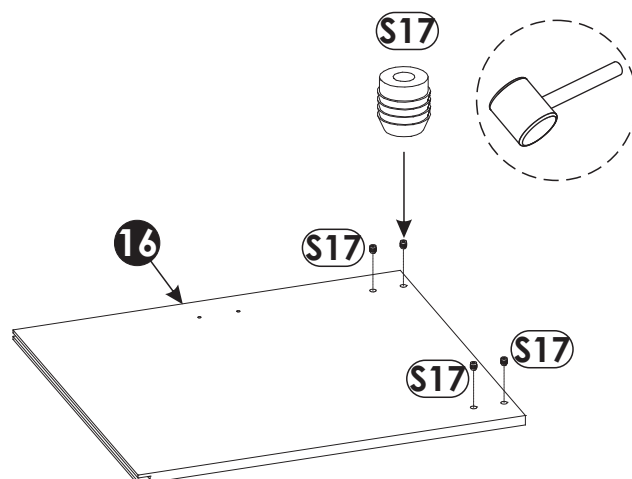
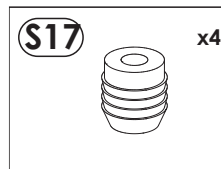
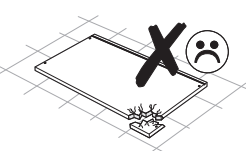
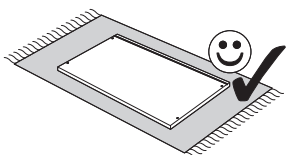

46 ▶

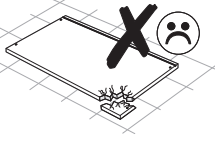
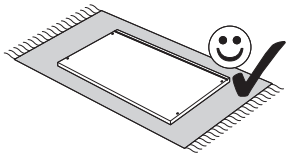

N0	x2	RL5	x2
3 X 13 mm		BE SC 18 28 00	
N1	x2	R5	x2
3 X 16 mm		RL1	x4
		Q1	x1

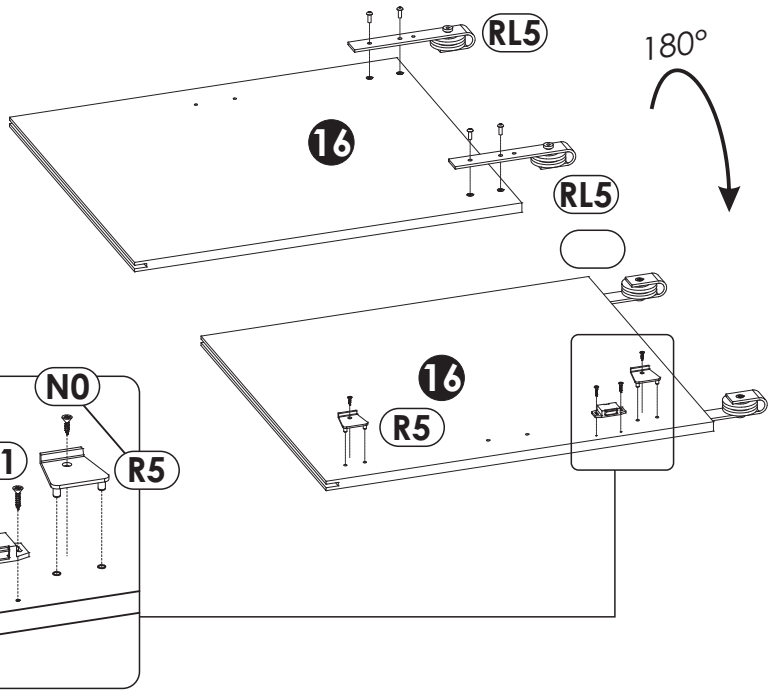
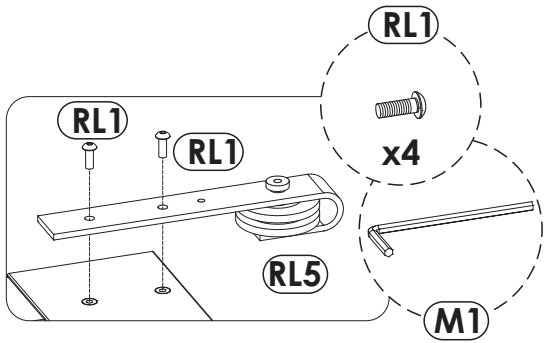
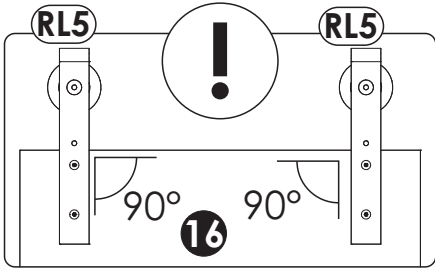

47 ▶

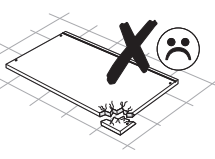
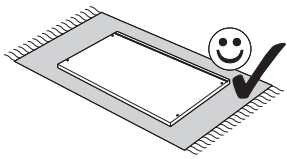

R8	x2

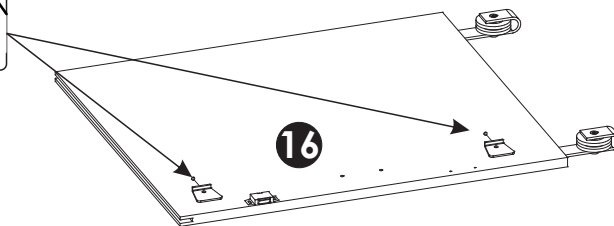
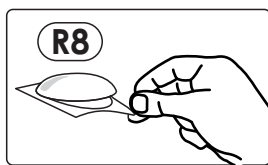



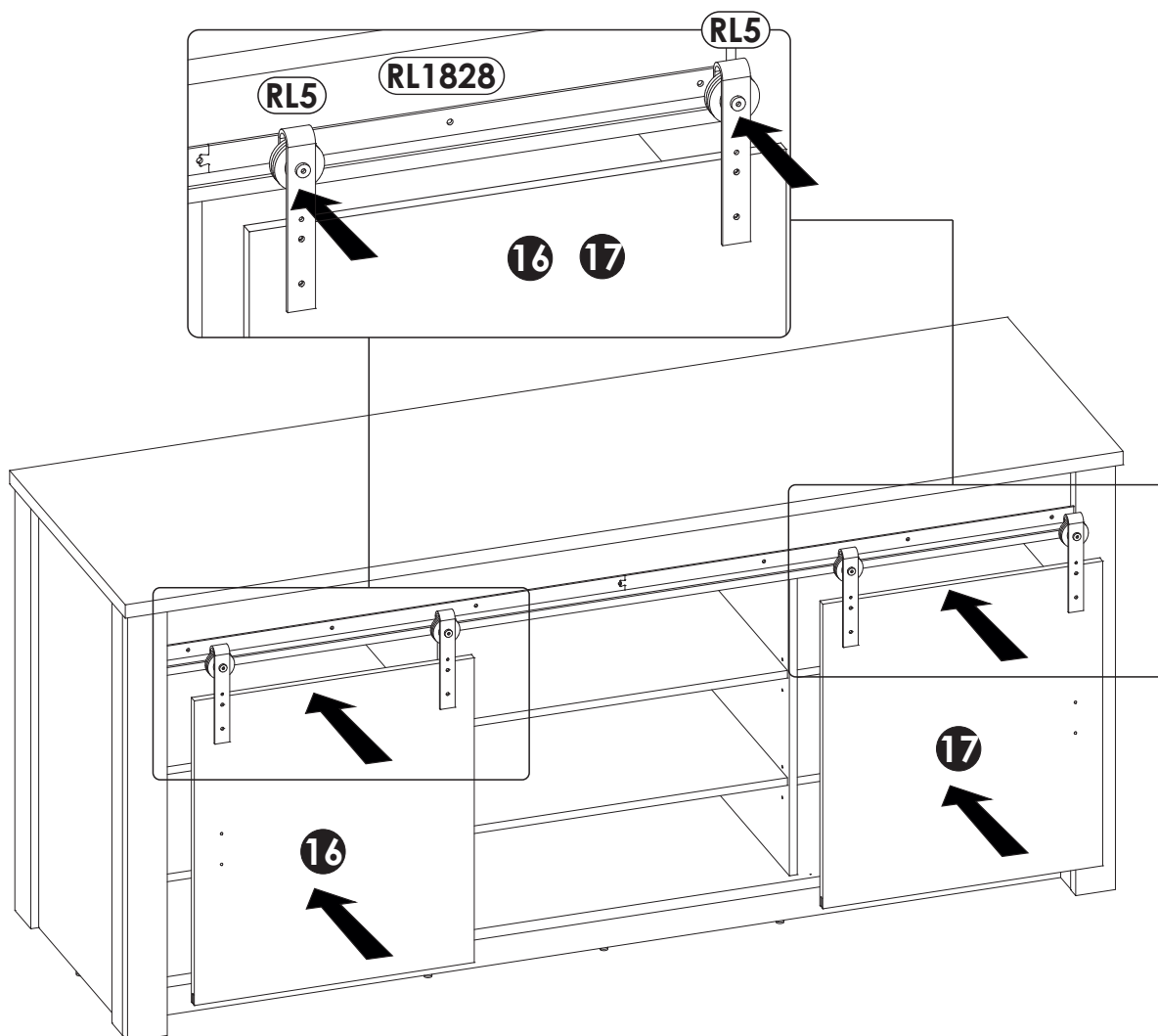
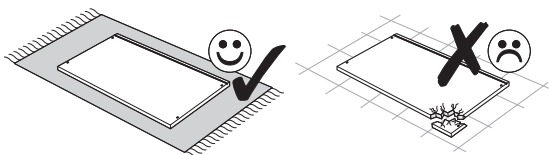

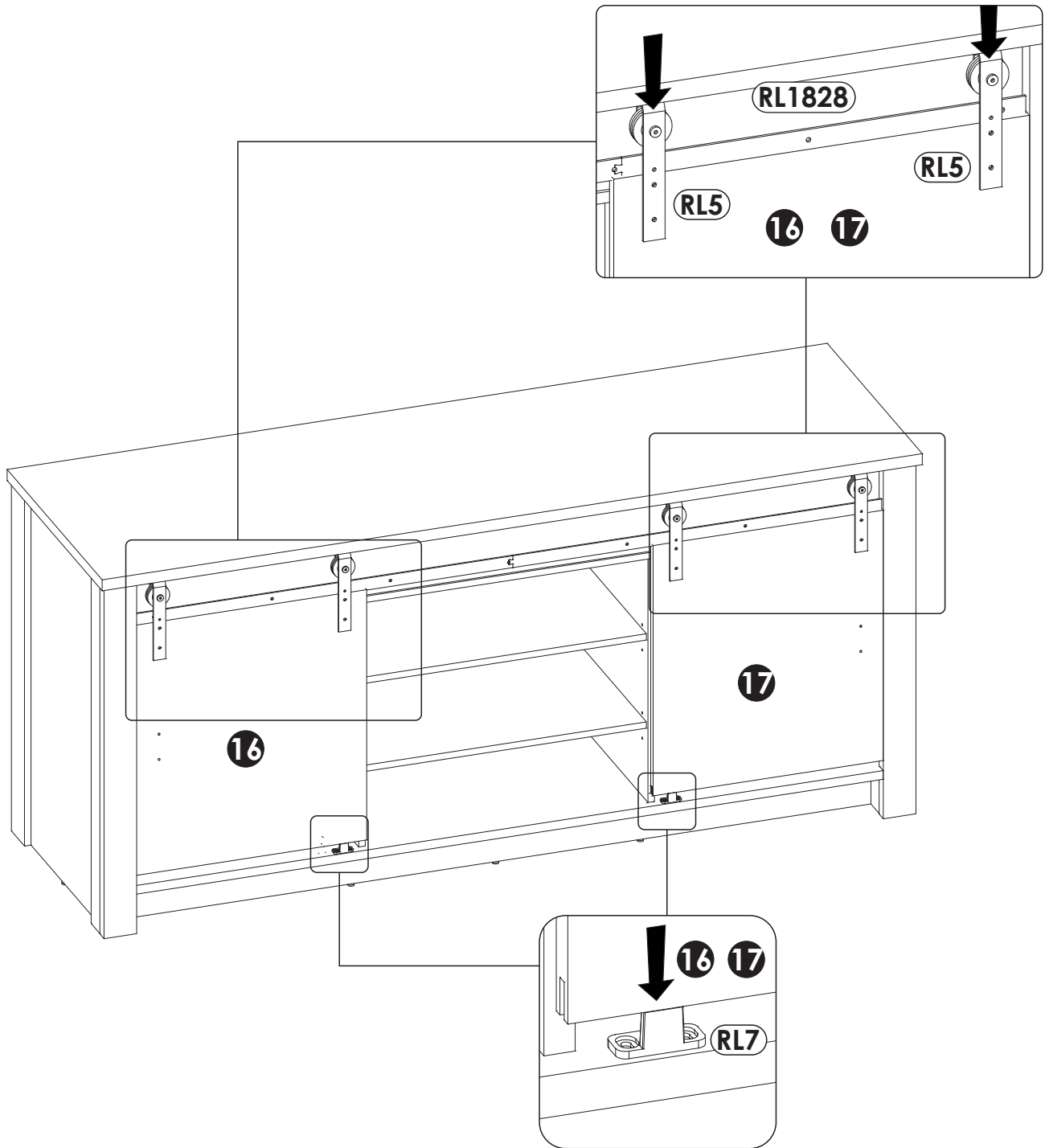
48 ▶





50 ▶

H2 x2  L - 78 mm	K7 x4  M4 x 22 mm	RL6 x4 	RL3 x4 
---	--	---	--

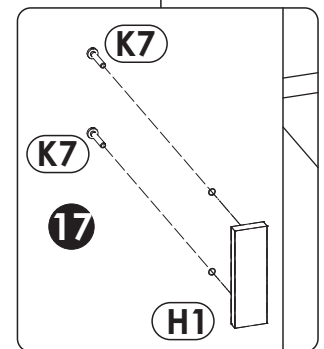
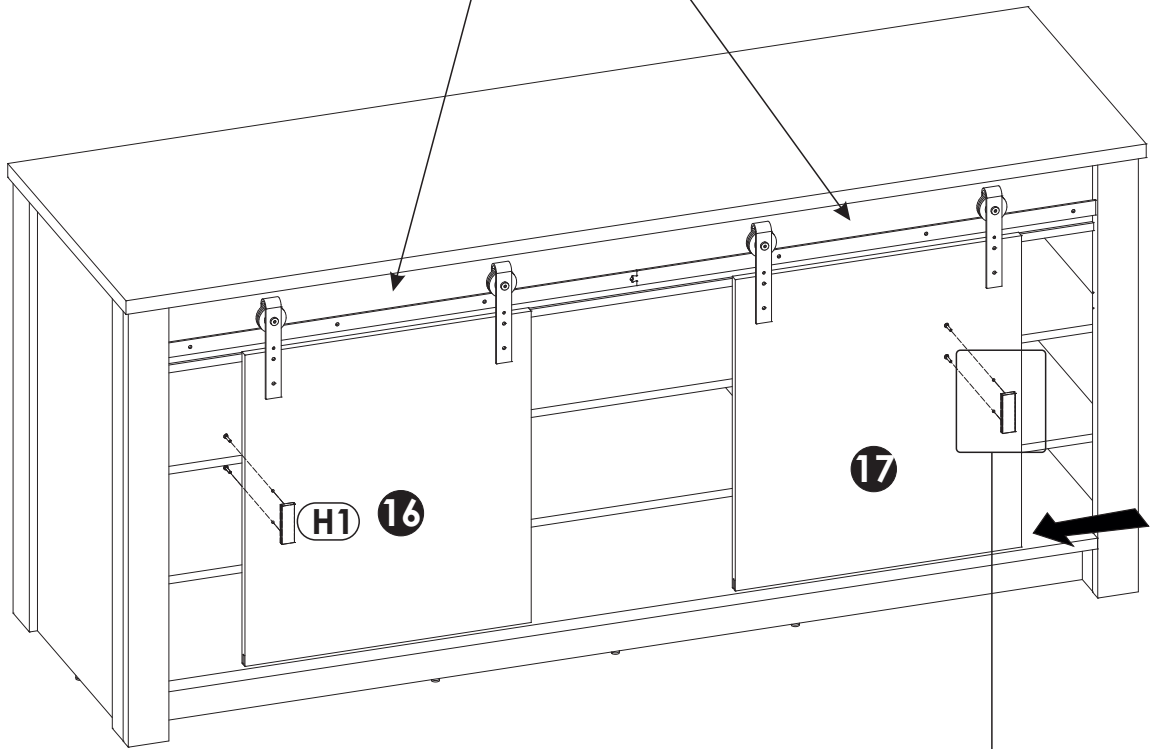
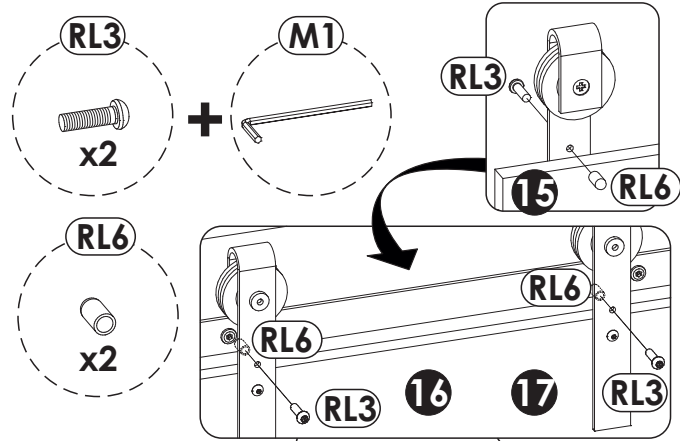

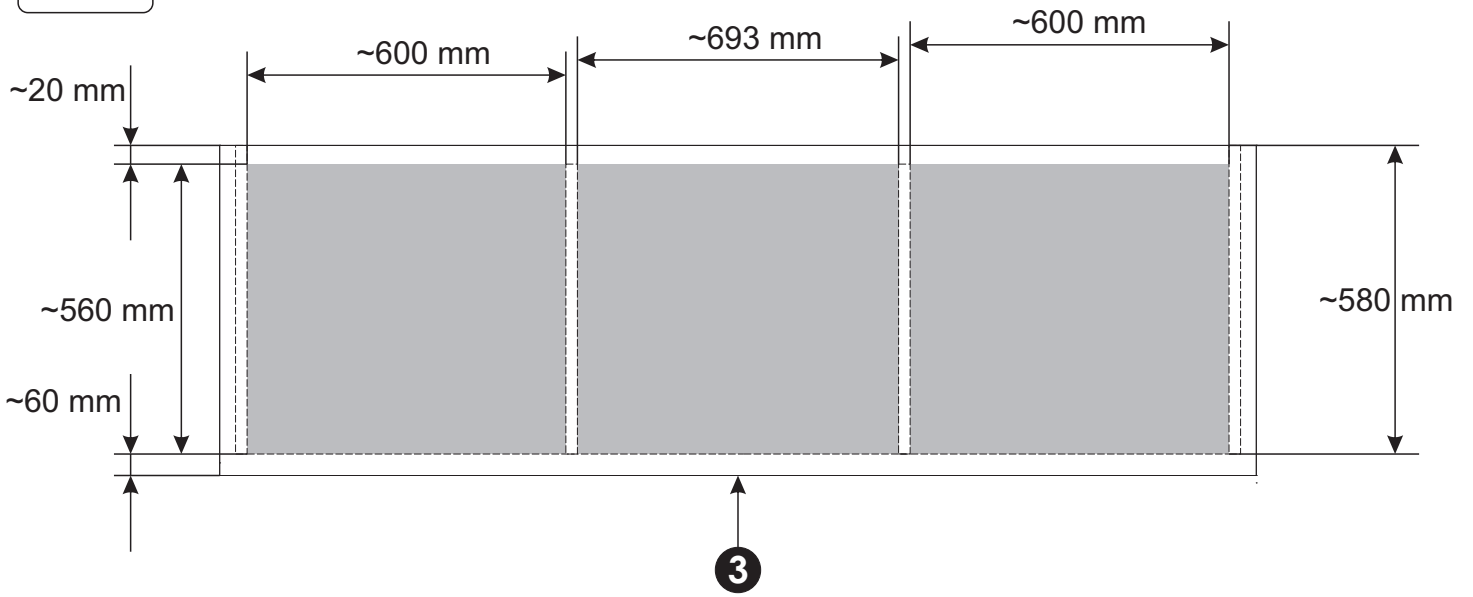

OPTION A

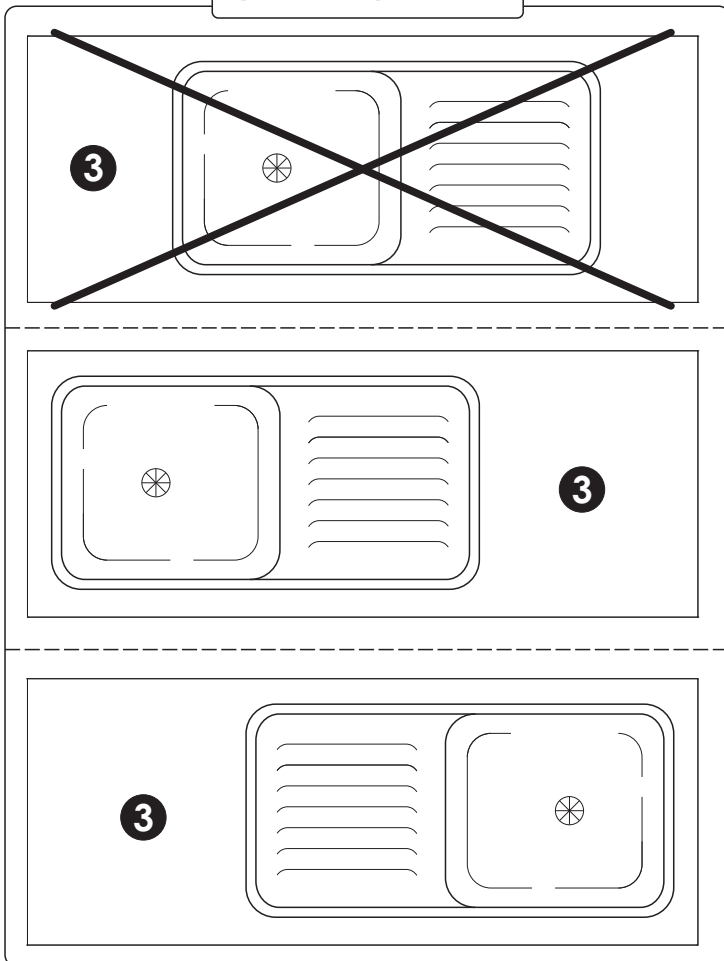

OPTION B

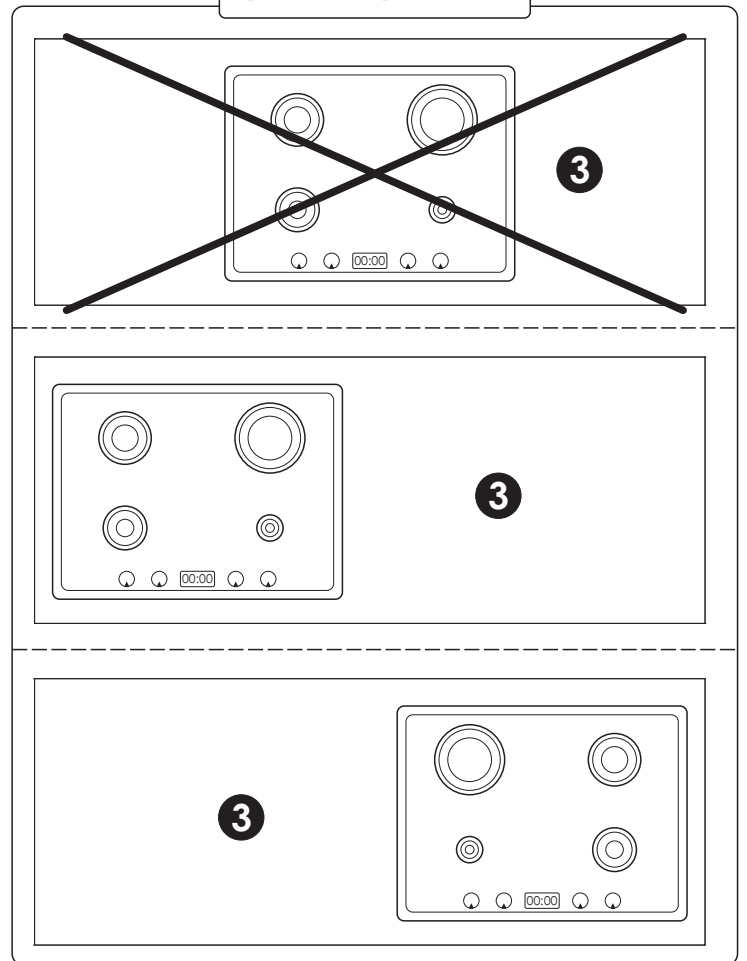

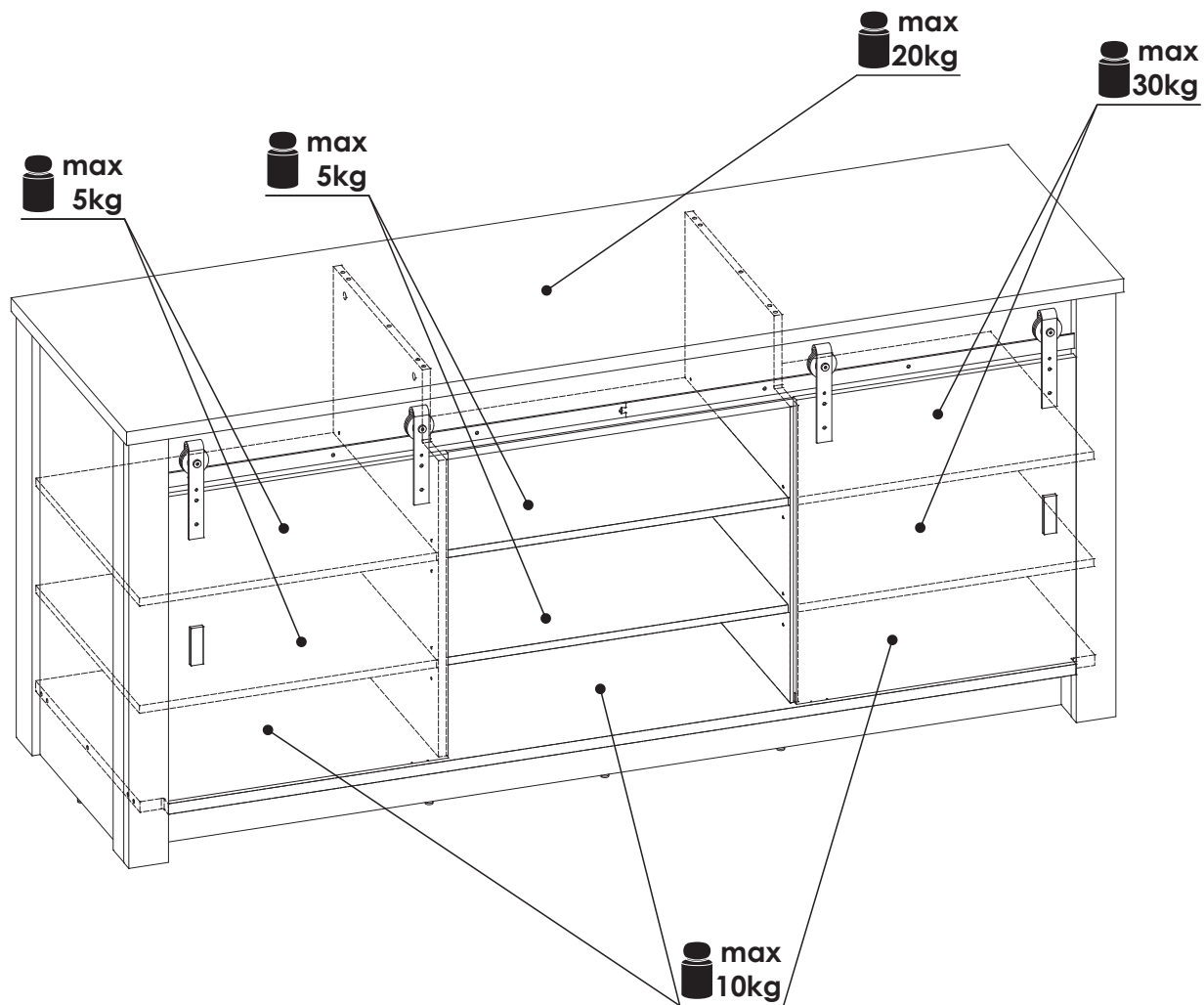

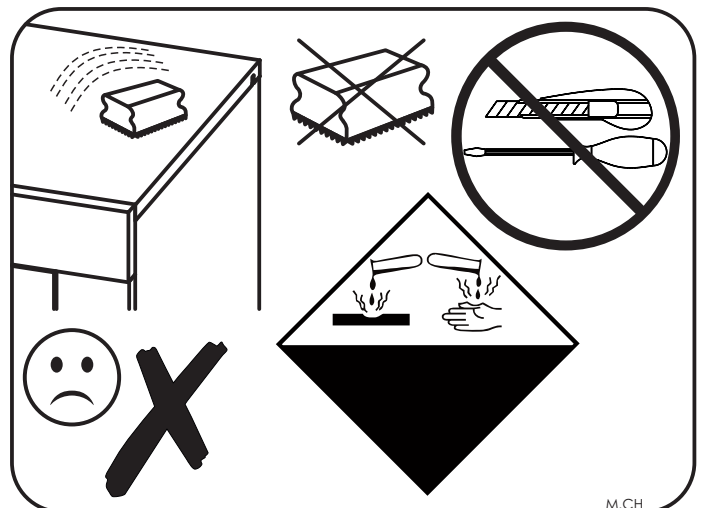
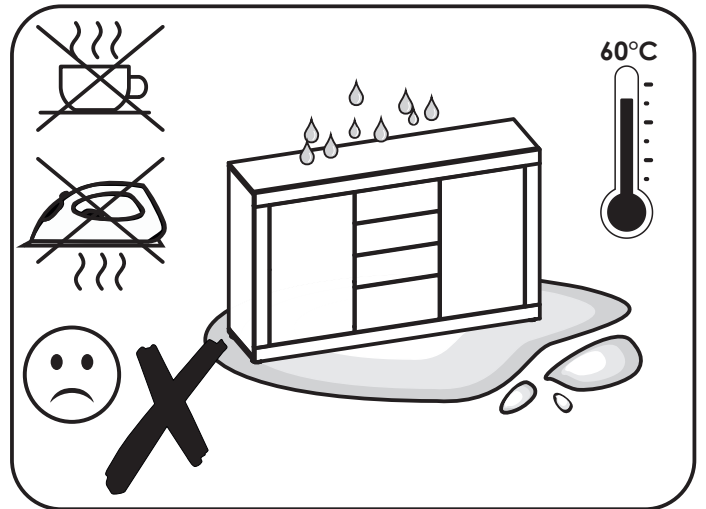
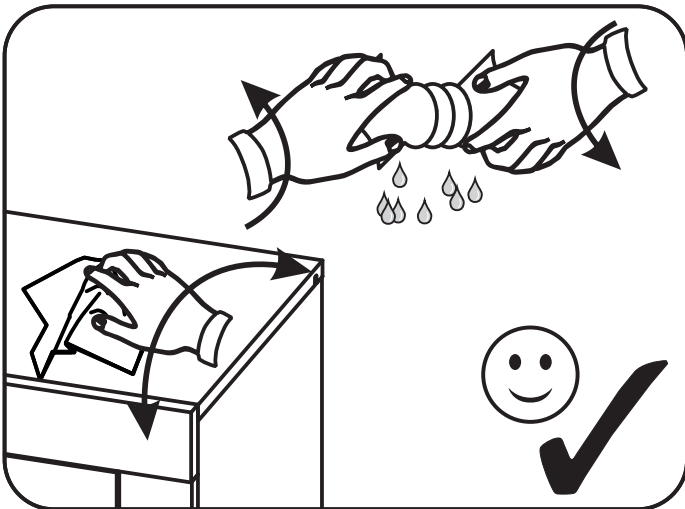
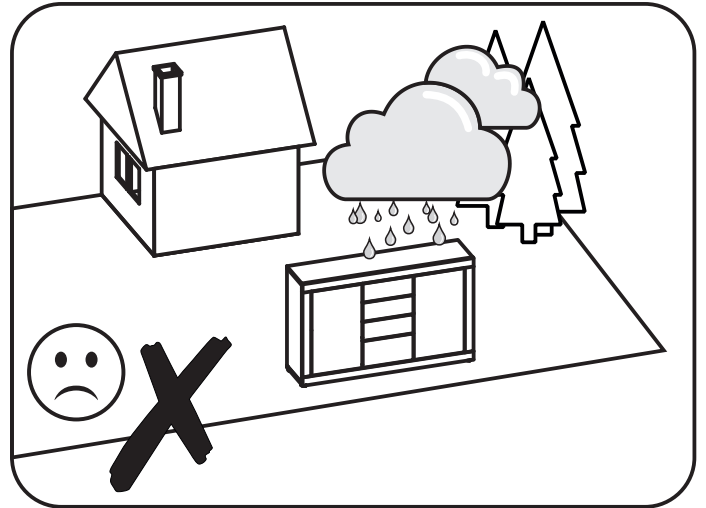
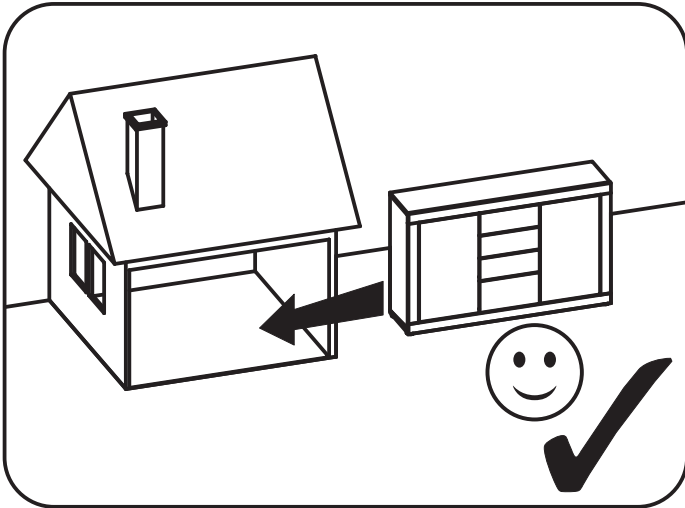
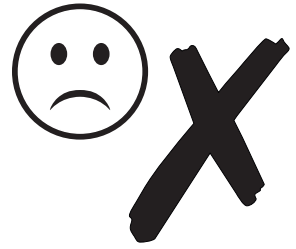

1YYASCD1/1PPASCD1

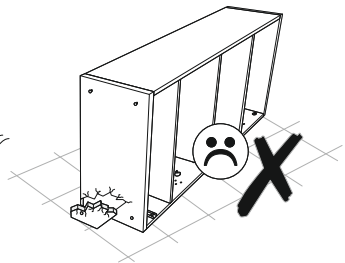
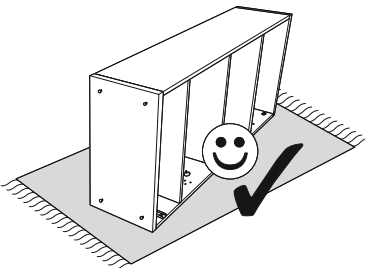
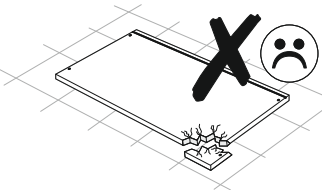
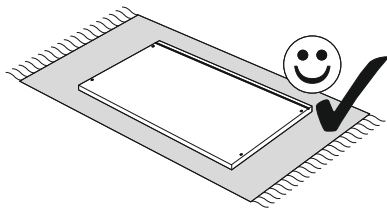
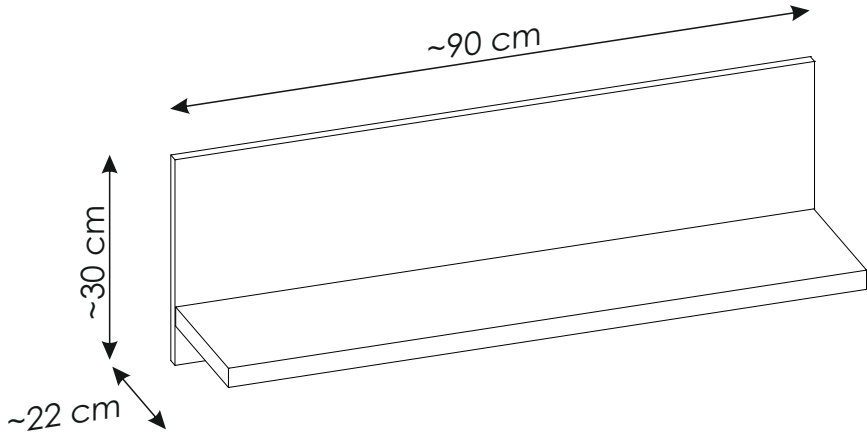
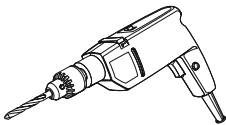
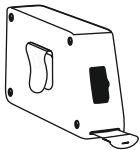
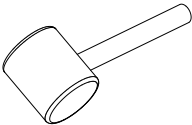
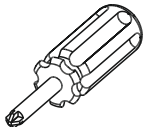
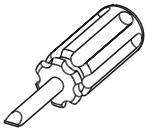
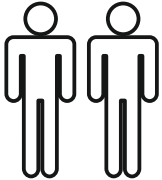

PL.
UWAGA! Mebel należy trwale zamocować do ściany, aby uniknąć ryzyka związanego z przewróceniem się mebla. W paczce nie ma śrub mocujących, ponieważ rodzaj mocowania należy odpowiednio dobrać do rodzaju ściany. Dobierz właściwe do Twojego rodzaju ściany.

D.
ACHTUNG! Um alle mit dem Umkippen des Möbels verbundenen Risiken auszuschließen, muss das Möbel fest an der Wand verankert werden. Beschläge für die Wandbefestigung sind nicht beige packt, da diese von der jeweiligen Wandbeschaffenheit abhängig sind. Bitte solche Befestigungsschläge wählen, die für die heimischen Wände geeignet sind.

FR.
ATTENTION! Ce meuble doit être fixé en permanence au mur pour éviter les risques de chute. Les vis de fixation ne sont pas livrées car le type de fixation doit être choisi en fonction du type de mur. Sélectionnez les fixations adaptées au mur.

I.
ATTENZIONE! Il mobile deve essere permanentemente fissato alla parete per evitare i rischi derivanti da un ribaltamento del mobile. La confezione non include le viti di fissaggio, in quanto il tipo di fissaggio deve essere scelto in base al tipo di parete. Utilizzare viti appropriate in base al materiale della parete.

HR.
NAPOMENA! Namještaj mora biti trajno pričvršćen za zid, kako bi se izbjegao rizik od njegovog prevrtanja. U paketu nema vijaka za pričvršćivanje, jer se vrsta montaže mora prilagoditi vrsti zida. Odaberite pravu vrstu prema Vašoj vrsti zida.

EN.
WARNING! To prevent this furniture from tripping over, fix it to the wall permanently. Fixing devices are not included since different wall materials require different types of fixing devices. Please make sure you chose the correct ones for your type of wall.

SK.
POZOR! Nábytok musí byť trvalo pripevnený k stene tak, aby sa zamedzilo riziku prevrátenia. Balík neobsahuje upevňovacie skrutky, pretože typ upevnenia je treba vybrať podľa typu steny. Vyberte typ vhodný pre Vašu stenu.

CZ.
POZOR! Nábytek je nutné pevně připevnit ke zdi, abychom se vyhnuli riziku spojenému s jeho převrnutím. Součástí balení nejsou připevňovací šrouby, protože způsoby připevnění je nutné zvolit podle druhu stěny. Vyberte správný pro Váš typ stěny.

RU.
ПРИМЕЧАНИЕ! Эту мебель необходимо всегда прикреплять к стене, чтобы избежать рисков, связанных с переворотом мебели. В пакете нет крепежных винтов, потому что тип крепления должен быть выбран в соответствии с типом стены. Выберите, пожалуйста, правильные винты к вашей стене.

RO.
ATENȚIE! Mobila trebuie ancorată permanent în perete pentru a evita riscul de răsturnare a mobilei. În pachet nu sunt incluse șuruburile de fixare, deoarece tipul de ancoraj trebuie ales în funcție de tipul de perete. Alegeți șuruburile potrivite pentru tipul Dvs. de perete.

TR.
DİKKAT! Devrilme riskini önlemek için mobilya duvara sabitlenmelidir. Sabitleme civataları pakete dahil değil, çünkü sabitleme feribatinin tipi, duvara tipine uygun olarak seçilmelidir. Onu duvarınızın tipine göre seçiniz.

AR.
ملاحظة!

يجب تثبيت الأثاث بإحكام إلى الحائط أو الجدار لتجنب خطر إنقلابه. لا تحتوي العلبة على مسامير التثبيت، إذ إنه ينبغي إستعمال المسامير المخصصة لنوعية الحائط أو الجدار. اختر المسامير التي تناسب جدارك.

E.
¡ATENCIÓN! El mueble debe ser fijado permanentemente a la pared para evitar el riesgo relacionado con el vuelco del mueble. En el paquete no hay tornillos de fijación, ya que se debe elegir el tipo de fijación adecuado para el tipo de pared. Elija el apropiado para su tipo de pared.

CN.
注意！本家具需要固定在墙上以免倒塌。箱子里没有安装螺钉。因为安装方式需要根据墙的类型调整。请按照您的墙类型选择合适的安装方式。



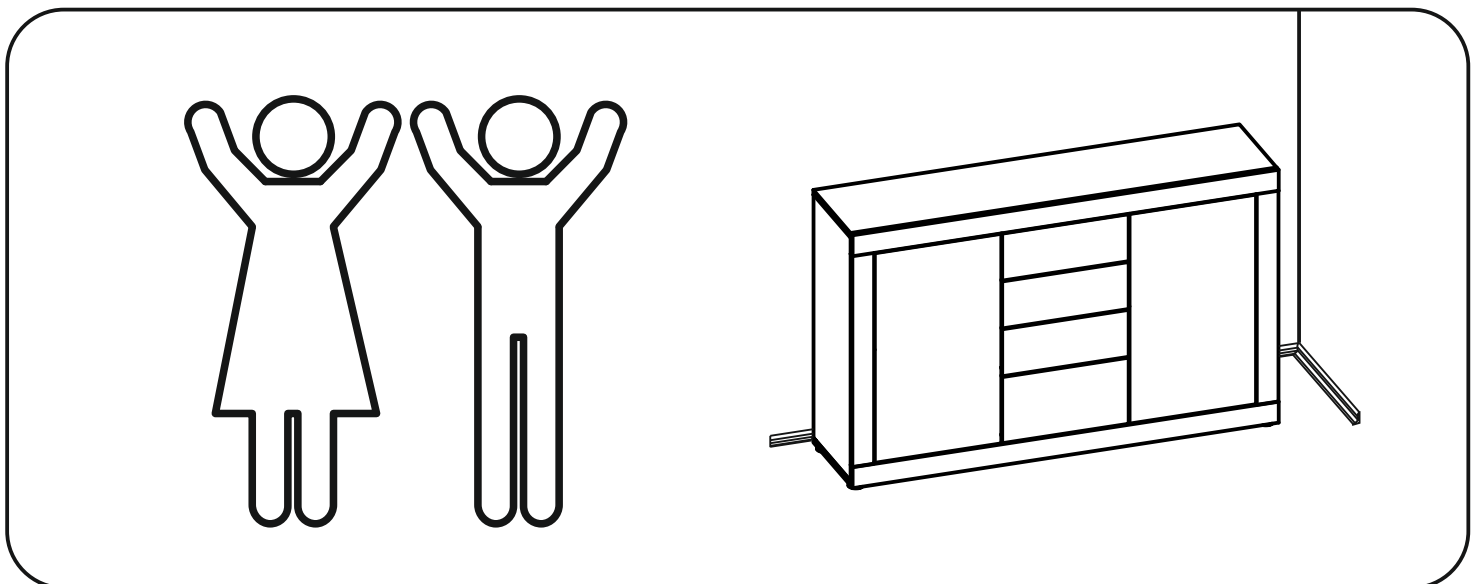
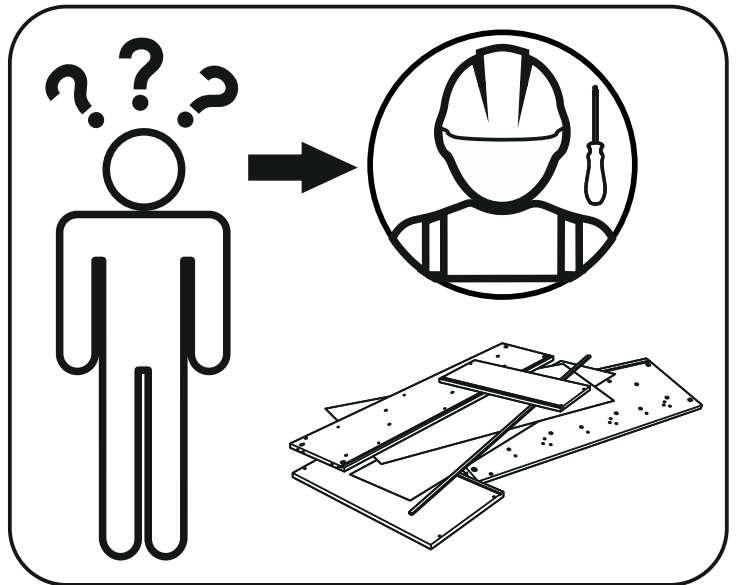
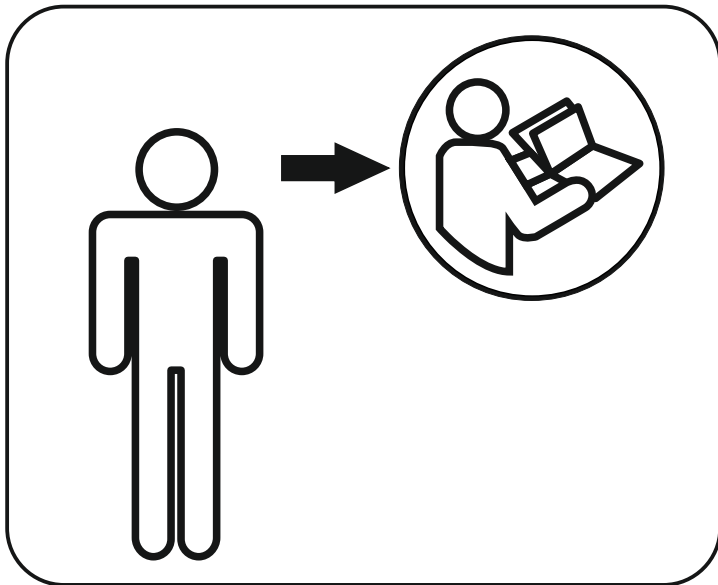
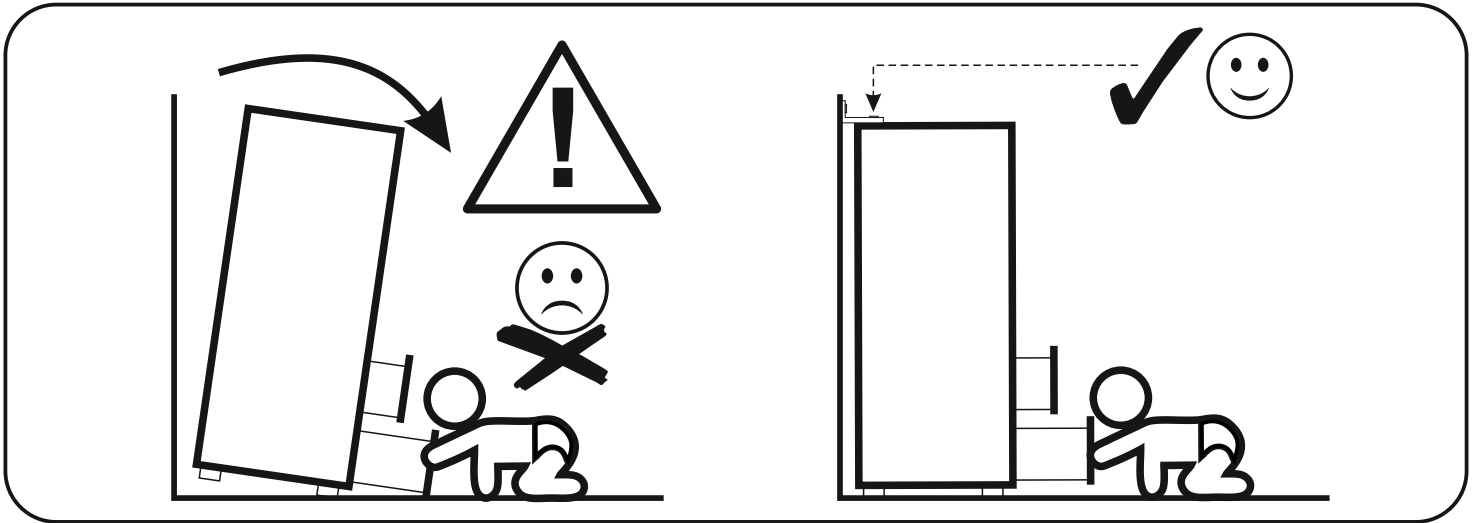
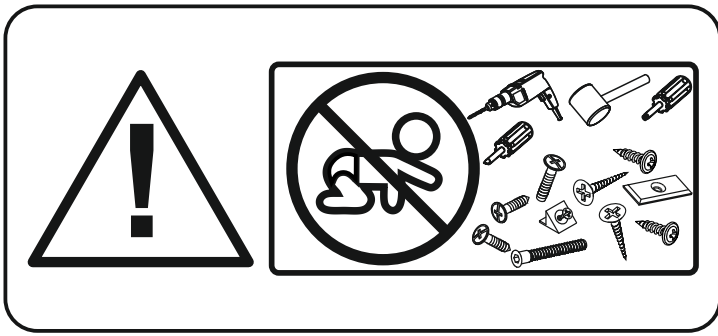

SLO.
POZOR! Pohišivo trajno pritrdite na steno, da preprečite tveganje, da se prevrne. V paketu ni pritrdilnih vijakov, saj je treba način pritrditve ustrezno izbrati glede na vrsto stene. Izberite način, ki je ustrezen za vašo steno.

HU.
FIGYELEM! Rögzítse a bútorokat a falhoz, hogy elkerülje a bútor felborulásának kockázatát. A készletben nem találhatóak rögzítőcsavarok, mivel a rögzítés típusa a fal típusától függ. Válassza ki a fal típusának megfelelő kötőelemeket.

NL.
OPMERKING! De meubelen moeten permanent aan de muur worden bevestigd om te voorkomen dat de meubelen kantelen. Er zitten geen bevestigingsschroeven in het pakket, omdat het type bevestiging moet worden gekozen op basis van het type muur. Kies de juiste voor uw type muur.

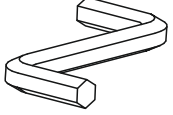

1YYASCD1/1PPASCD1

A1 8 x 35 mm x6 	C2 5 x 13 mm x4 	G2 7 x 60 mm x3 
M  x1	P1  x2	R7  x2

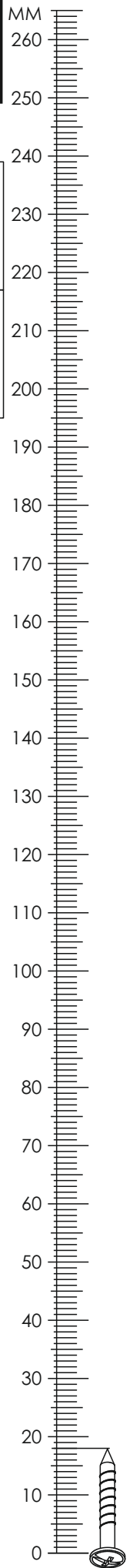

1YYASCD1/1PPASCD1

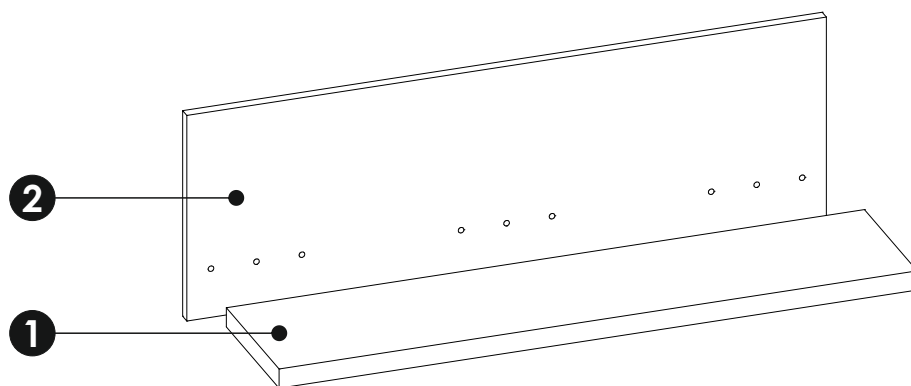
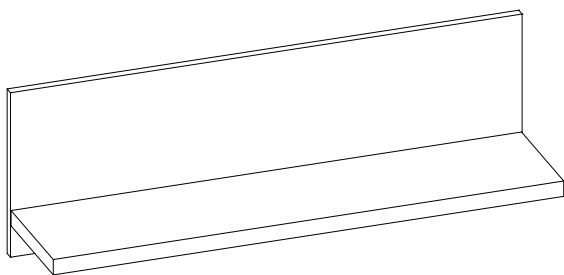

1	898	204	28	x1	1/1
2	900	300	16	x1	1/1

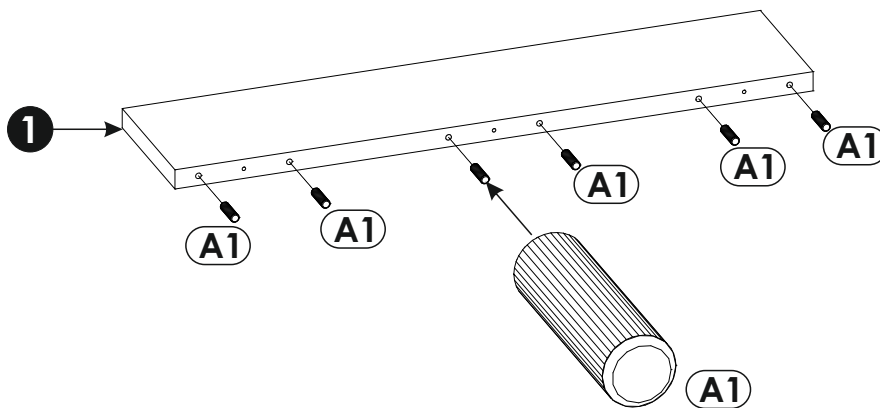
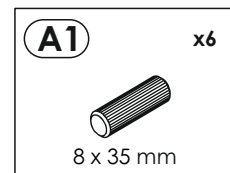
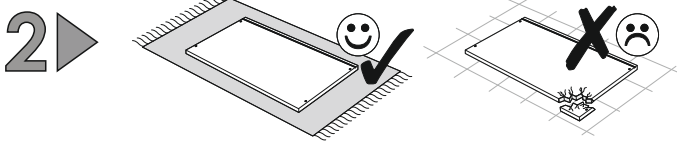
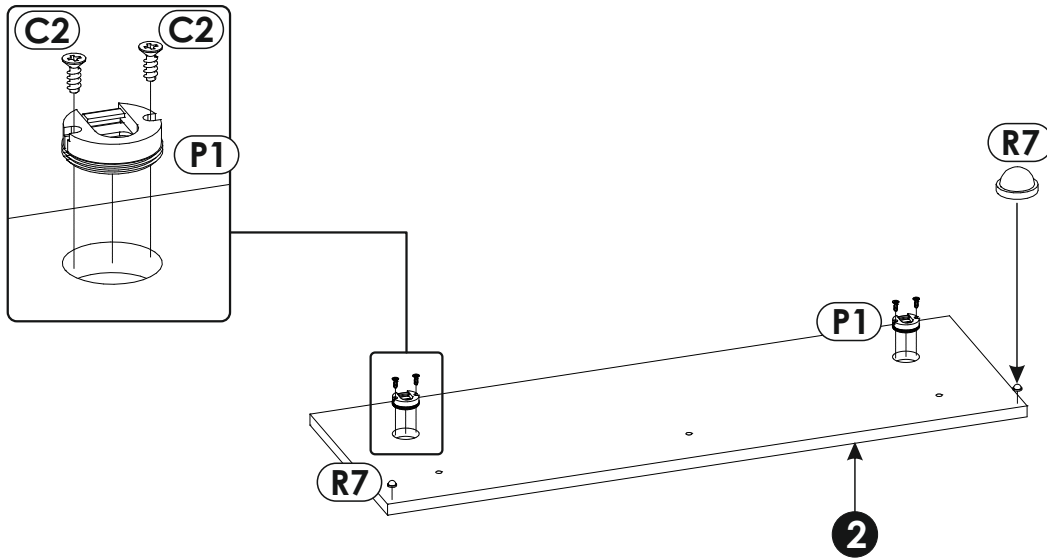
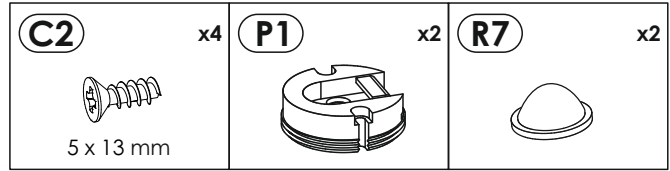
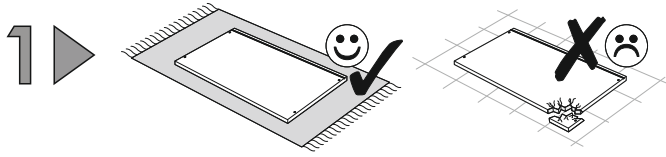
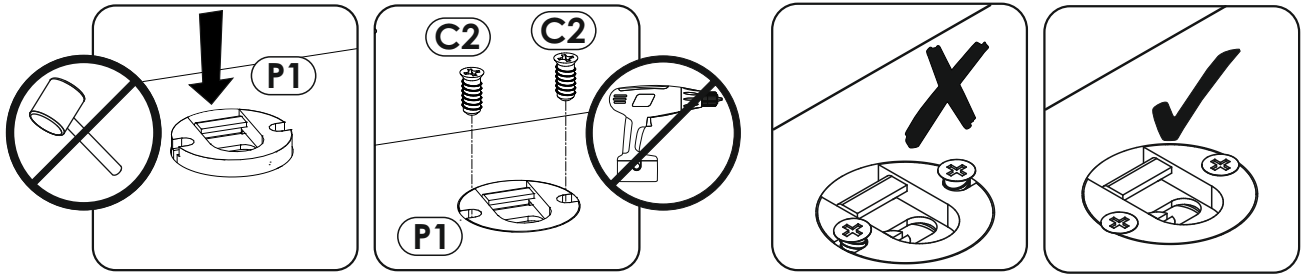

3 ▶

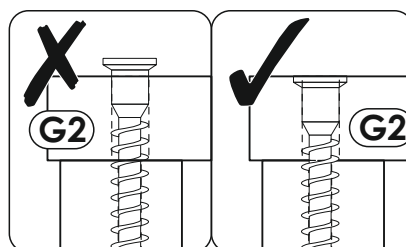
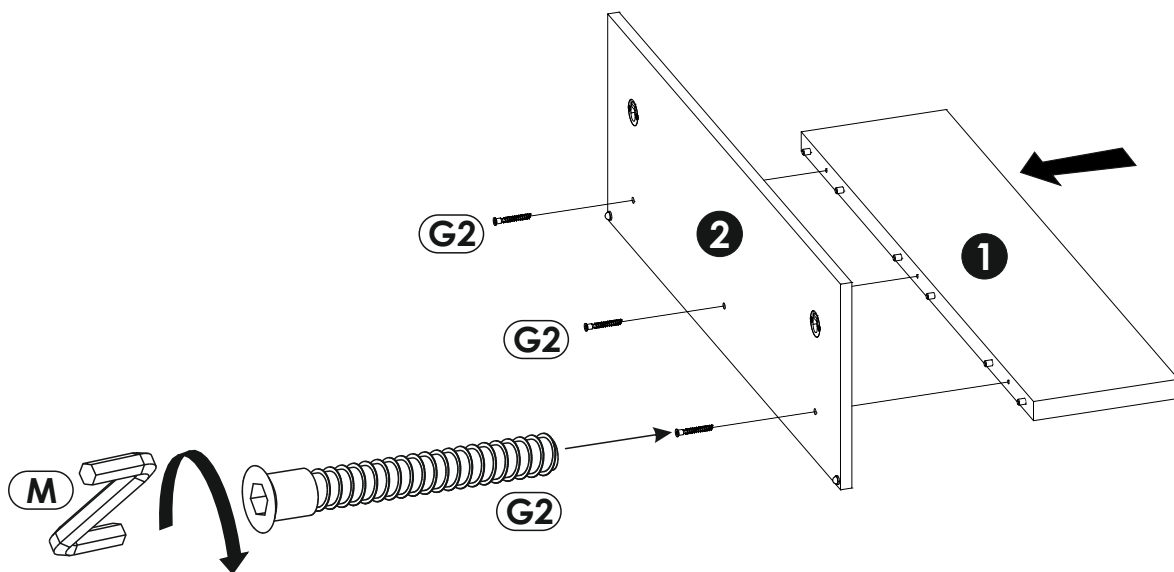
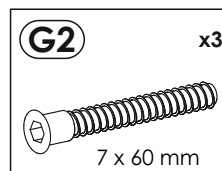
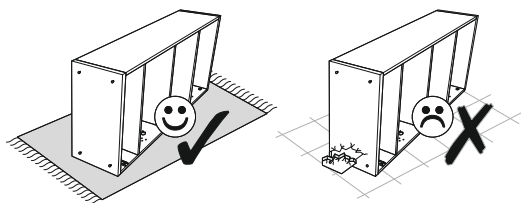

4 ▶

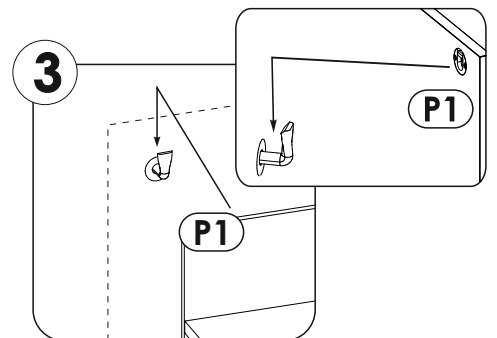
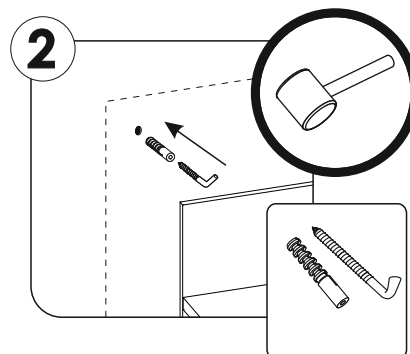
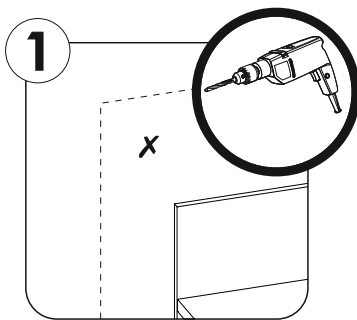
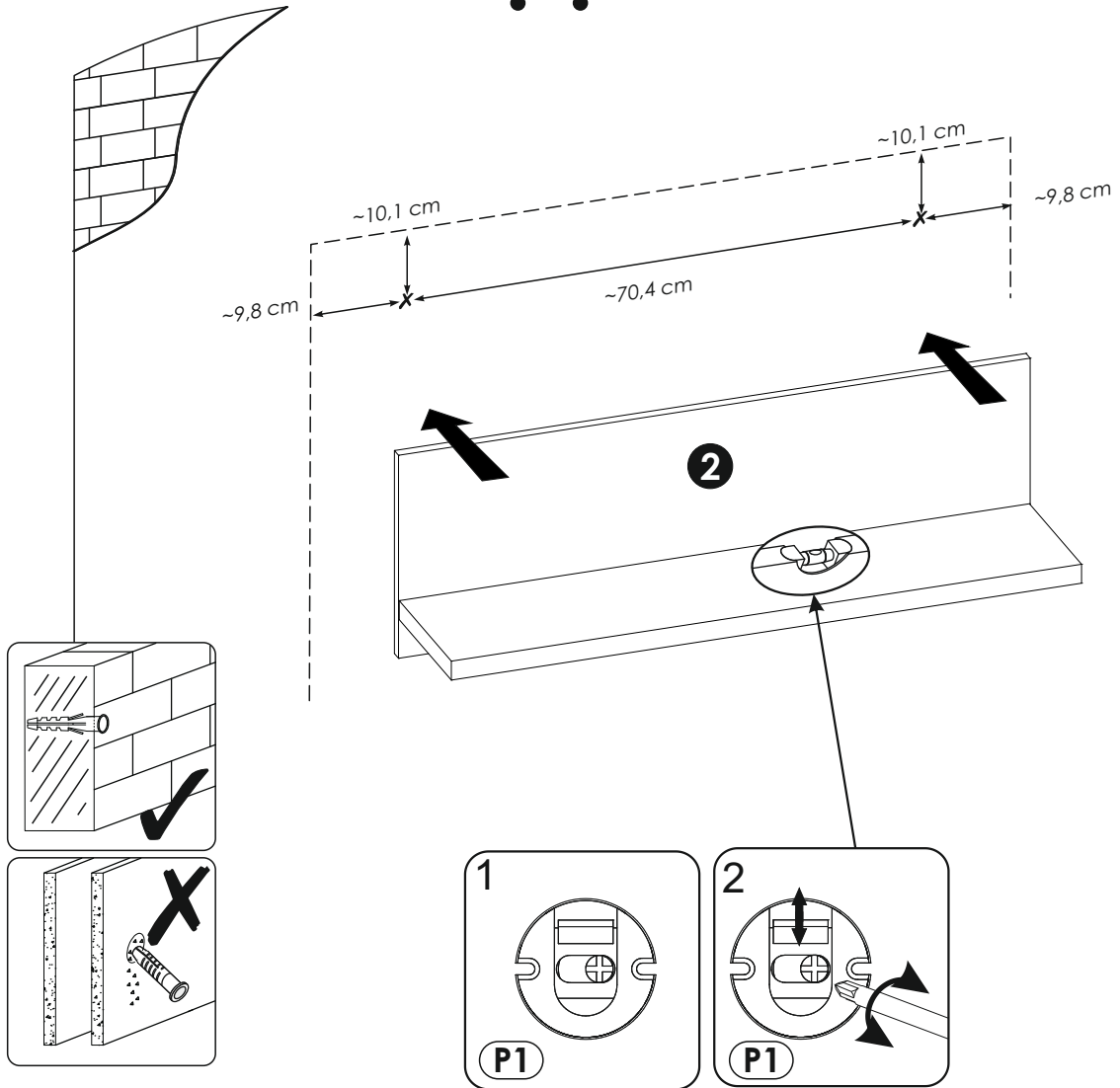

5 ▶

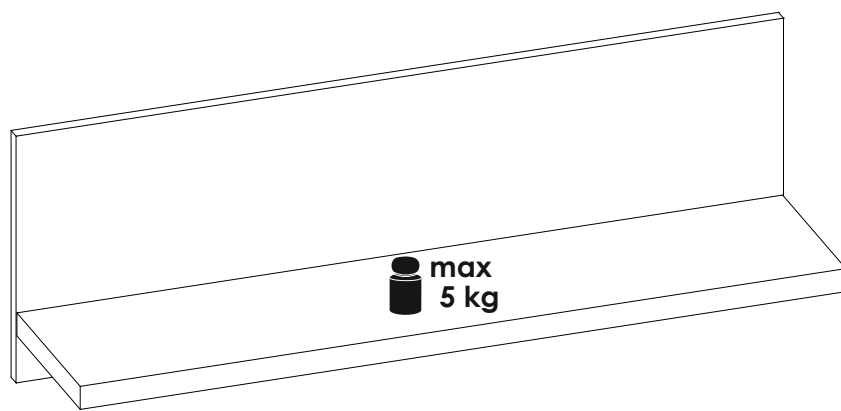

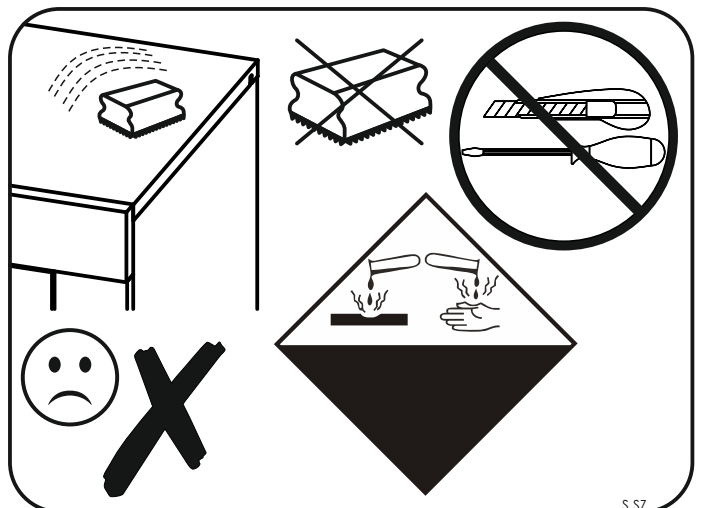
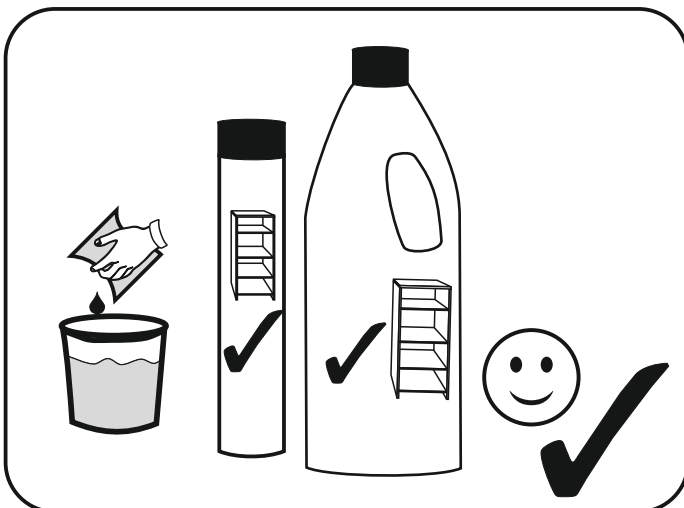
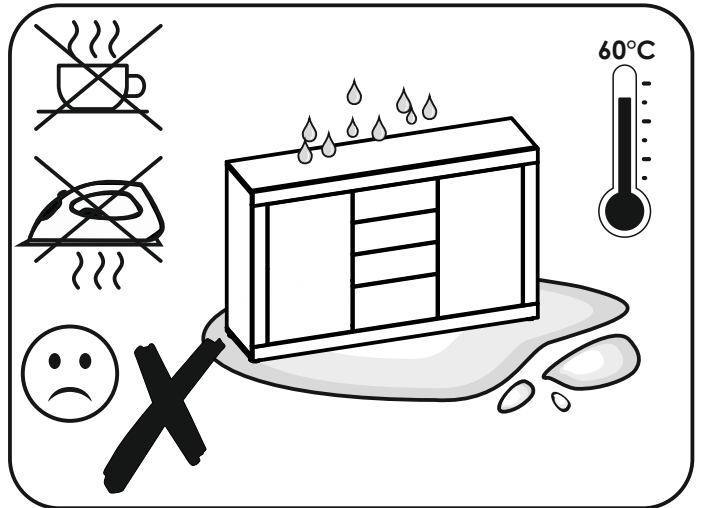
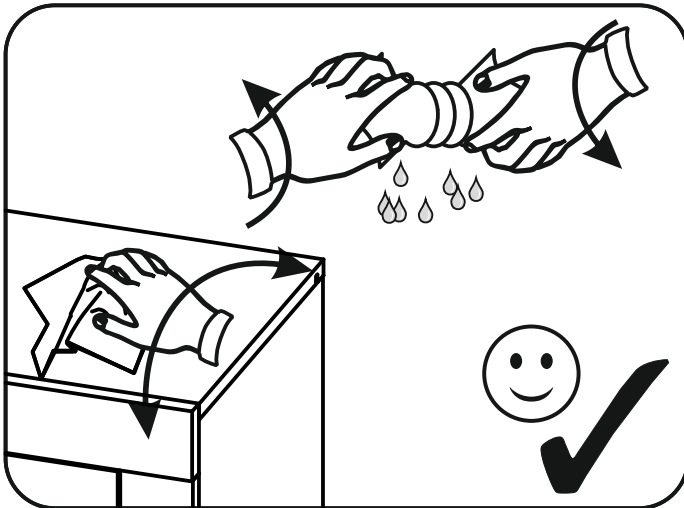
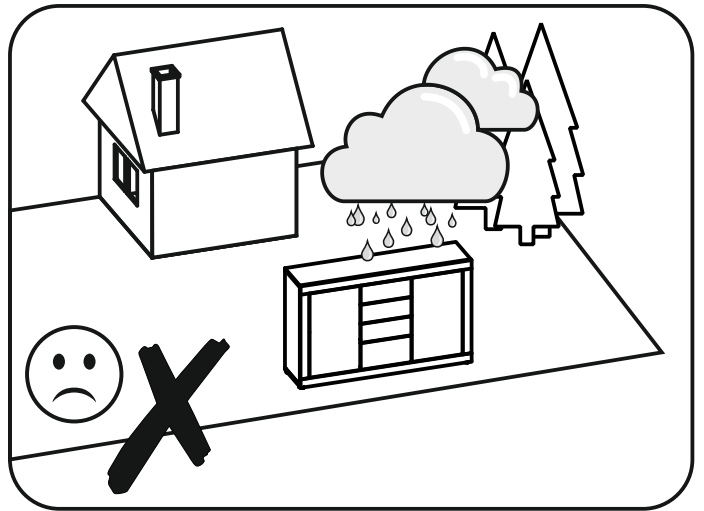
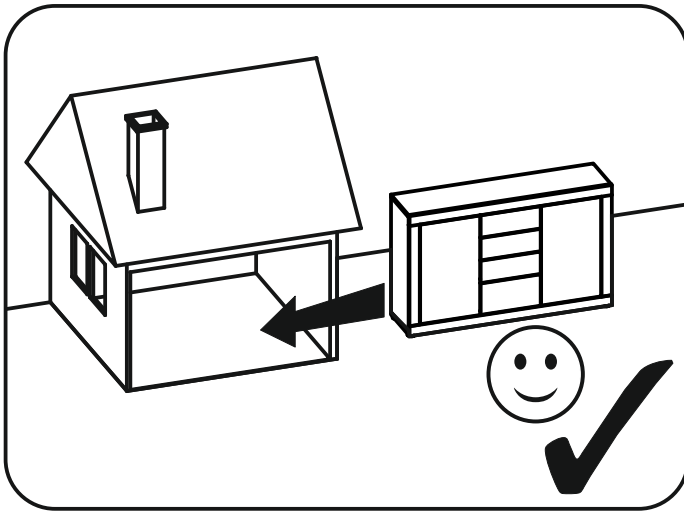
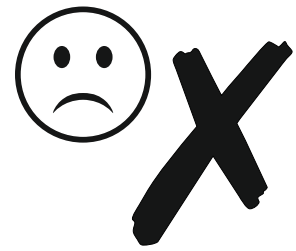

1YYASCE1/1PPASCE1

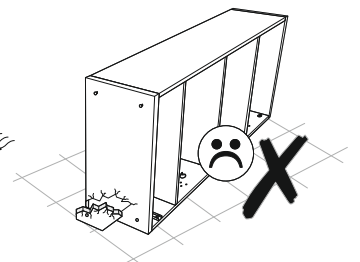
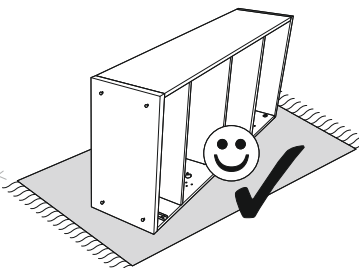
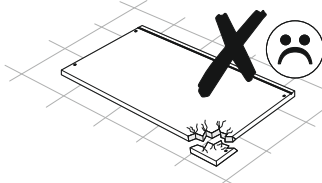
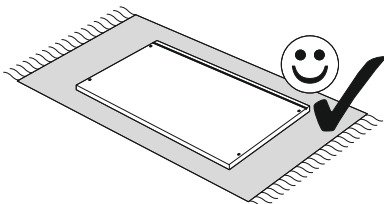
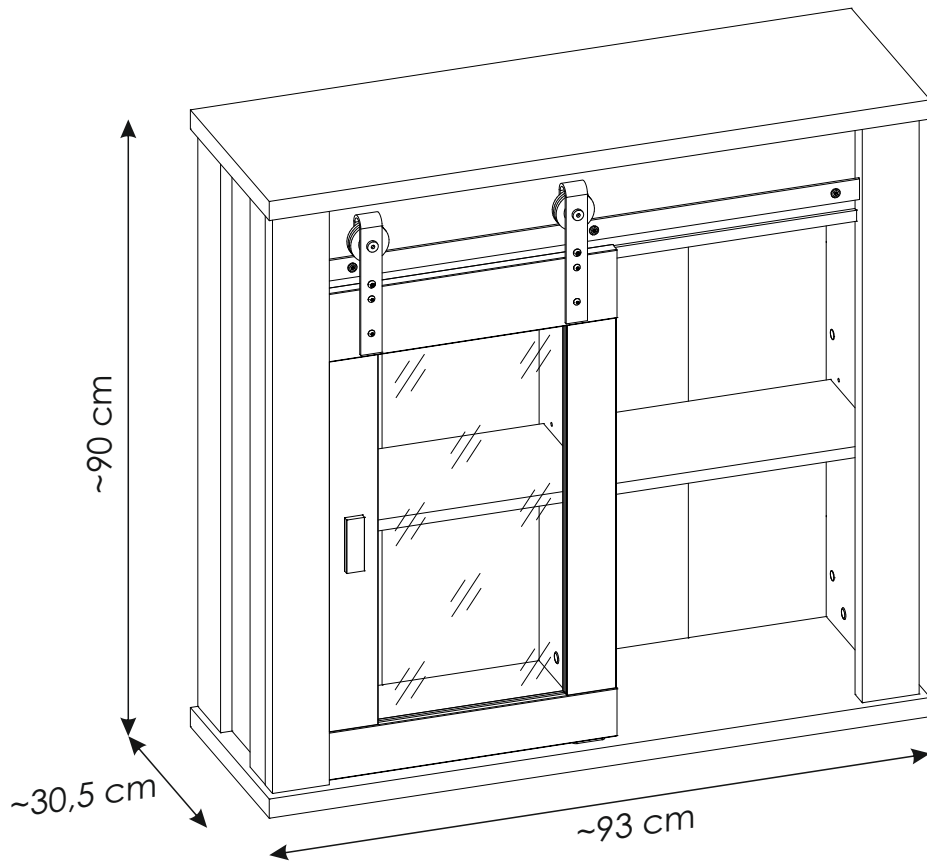
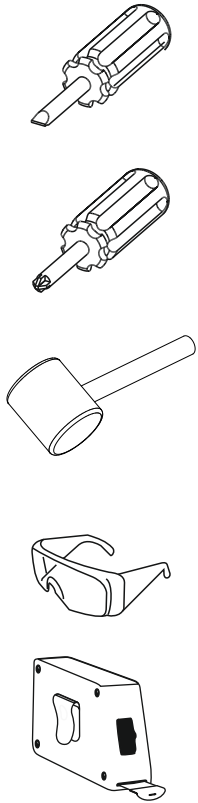
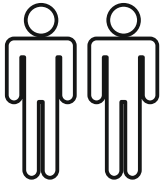

AR.

ملاحظة!

يجب تثبيت الأثاث بإحكام إلى الحائط أو الجدار لتجنب خطر إنقلابه. لا تحتوي العلبة على مسامير التثبيت، إذ إنه ينبغي إستعمال المسامير المخصصة لنوعية الحائط أو الجدار. اختر المسامير التي تناسب جدارك.

E.

¡ATENCIÓN! El mueble debe ser fijado permanentemente a la pared para evitar el riesgo relacionado con el vuelco del mueble. En el paquete no hay tornillos de fijación, ya que se debe elegir el tipo de fijación adecuado para el tipo de pared. Elija el apropiado para su tipo de pared.

CN.

注意！本家具需要固定在墙上以免倒塌。箱子里没有安装螺钉。因为安装方式需要根据墙的类型调整。请按照您的墙类型选择合适的安装方式。

SLO.

POZOR! Pohišvo trajno pritrдите na steno, da preprečite tveganje, da se prevrne. V paketu ni pritrđilnih vijakov, saj je treba način pritrđitve ustrezno izbrati glede na vrsto stene. Izberite način, ki je ustrezen za vašo steno.

HU.

FIGYELEM! Rögzítse a bútorokat a falhoz, hogy elkerülje a bútor felborulásának kockázatát. A készletben nem találhatóak rögzítőcsavarok, mivel a rögzítés típusa a fal típusától függ. Válassza ki a fal típusának megfelelő kötőelemeket.

NL.

OPMERKING! De meubelen moeten permanent aan de muur worden bevestigd om te voorkomen dat de meubelen kantelen. Er zitten geen bevestigingsschroeven in het pakket, omdat het type bevestiging moet worden gekozen op basis van het type muur. Kies de juiste voor uw type muur.

EN.

WARNING! To prevent this furniture from tripping over, fix it to the wall permanently. Fixing devices are not included since different wall materials require different types of fixing devices. Please make sure you chose the correct ones for your type of wall.

SK.

POZOR! Nábytok musí byť trvalo pripevnený k stene tak, aby sa zamedzilo riziku prevrátenia. Balík neobsahuje upevňovacie skrutky, pretože typ upevnenia je treba vybrať podľa typu steny. Vyberte typ vhodný pre Vašu stenu.

CZ.

POZOR! Nábytek je nutné pevně připevnit ke zdi, abychom se vyhnuli riziku spojenému s jeho převrnutím. Součástí balení nejsou připevňovací šrouby, protože způsoby připevnění je nutné zvolit podle druhu stěny. Vyberte správný pro Váš typ stěny.

RU.

ПРИМЕЧАНИЕ! Эту мебель необходимо всегда прикреплять к стене, чтобы избежать рисков, связанных с переворотом мебели. В пакете нет крепежных винтов, потому что тип крепления должен быть выбран в соответствии с типом стены. Выберите, пожалуйста, правильные винты к вашей стене.

RO.

ATENŢIE! Mobila trebuie ancorată permanent în perete pentru a evita riscul de răsturnare a mobilei. În pachet nu sunt incluse şuruburile de fixare, deoarece tipul de ancoraj trebuie ales în funcţie de tipul de perete. Alegeţi şuruburile potrivite pentru tipul Dvs. de perete.

TR.

DİKKAT! Devrilmeye riskini önlemek için mobilya duvara sabitlenmelidir. Sabitleme civataları pakete dahil değildir, çünkü sabitleme tertibatının tipi, duvara tipine uygun olarak seçilmelidir. Onu duvarınızın tipine göre seçiniz.

PL.

UWAGA! Mebel należy trwale zamocować do ściany, aby uniknąć ryzyka związanego z przewróceniem się mebla. W paczce nie ma śrub mocujących, ponieważ rodzaj mocowania należy odpowiednio dobrać do rodzaju ściany. Dobierz właściwe do Twojego rodzaju ściany.

D.

ACHTUNG! Um alle mit dem Umkippen des Möbels verbundenen Risiken auszuschließen, muss das Möbel fest an der Wand verankert werden. Beschläge für die Wandbefestigung sind nicht beige packt, da diese von der jeweiligen Wandbeschaffenheit abhängig sind. Bitte solche Befestigungsschläge wählen, die für die heimischen Wände geeignet sind.

FR.

ATTENTION! Ce meuble doit être fixé en permanence au mur pour éviter les risques de chute. Les vis de fixation ne sont pas livrées car le type de fixation doit être choisi en fonction du type de mur. Sélectionnez les fixations adaptées au mur.

I.

ATTENZIONE! Il mobile deve essere permanentemente fissato alla parete per evitare i rischi derivanti da un ribaltamento del mobile. La confezione non include le viti di fissaggio, in quanto il tipo di fissaggio deve essere scelto in base al tipo di parete. Utilizzare viti appropriate in base al materiale della parete.









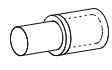
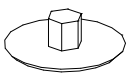

HR.

NAPOMENA! Namještaj mora biti trajno pričvršćen za zid, kako bi se izbjegao rizik od njegovog prevrtanja. U paketu nema vijaka za pričvršćivanje, jer se vrsta montaže mora prilagoditi vrsti zida. Odaberite pravu vrstu prema Vašoj vrsti zida.

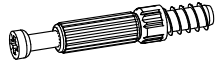

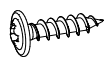
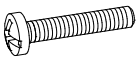
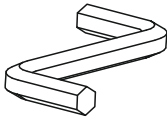
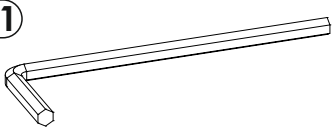
1YYASCE1/1PPASCE1

MM

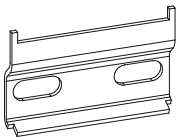
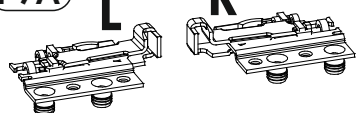
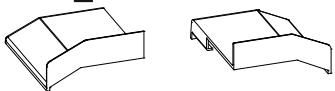
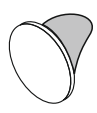
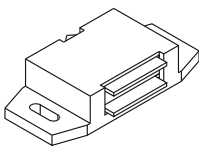
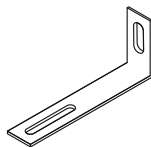
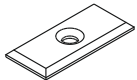
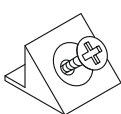
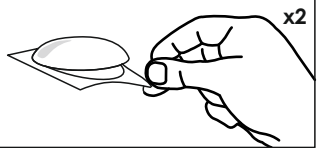
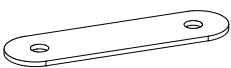
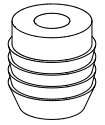
A0 8 x 20 mm x8 	A1 8 x 35 mm x36 	D2  x8
E0 Ø16 x16 	E1 15 x 12 mm x28 	F1 6 x 34 mm x28 
H2 L - 78 mm x1 	I0 3 x 13 mm x2 	I2 4 x 16 mm x1 
K7 4 x 22 mm x2 	M  x1	M1  x1
N1 3 x 16 mm x15 	N5 3,5 x 16 mm x4 	N14 4 x 30 mm x12 
P8B  x2	P9A L R  x1	P9B L R  x1
P16  x8	Q1  x1	Q9  x1
R1  x4	R4  x6	R8  x2
R10  x1	S17  x4	

260

250

240

230

220

210

200

190

180

170

160

150

140

130

120

110

100

90

80

70

60

50

40

30

20

10

0



1YYASCE1/1PPASCE1

MM

260

250

240

230

220

210

200

190

180

170

160

150

140

130

120

110

100

90

80

70

60

50

40

30

20

10

0

BE SC 07 48 00

x1

RL748

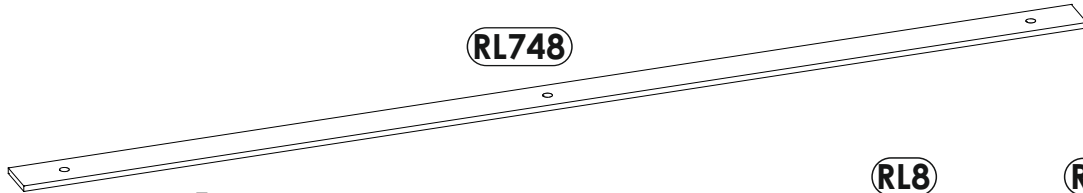

x1

RL8



x3

RL4

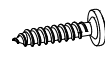

x3

RL1



x4

RL3



x2

RL2



x2

RL5

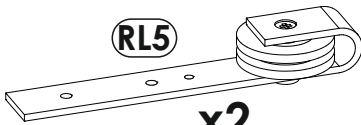

x2

RL6



x2

RL7



x1

1YYASCE1/1PPASCE1

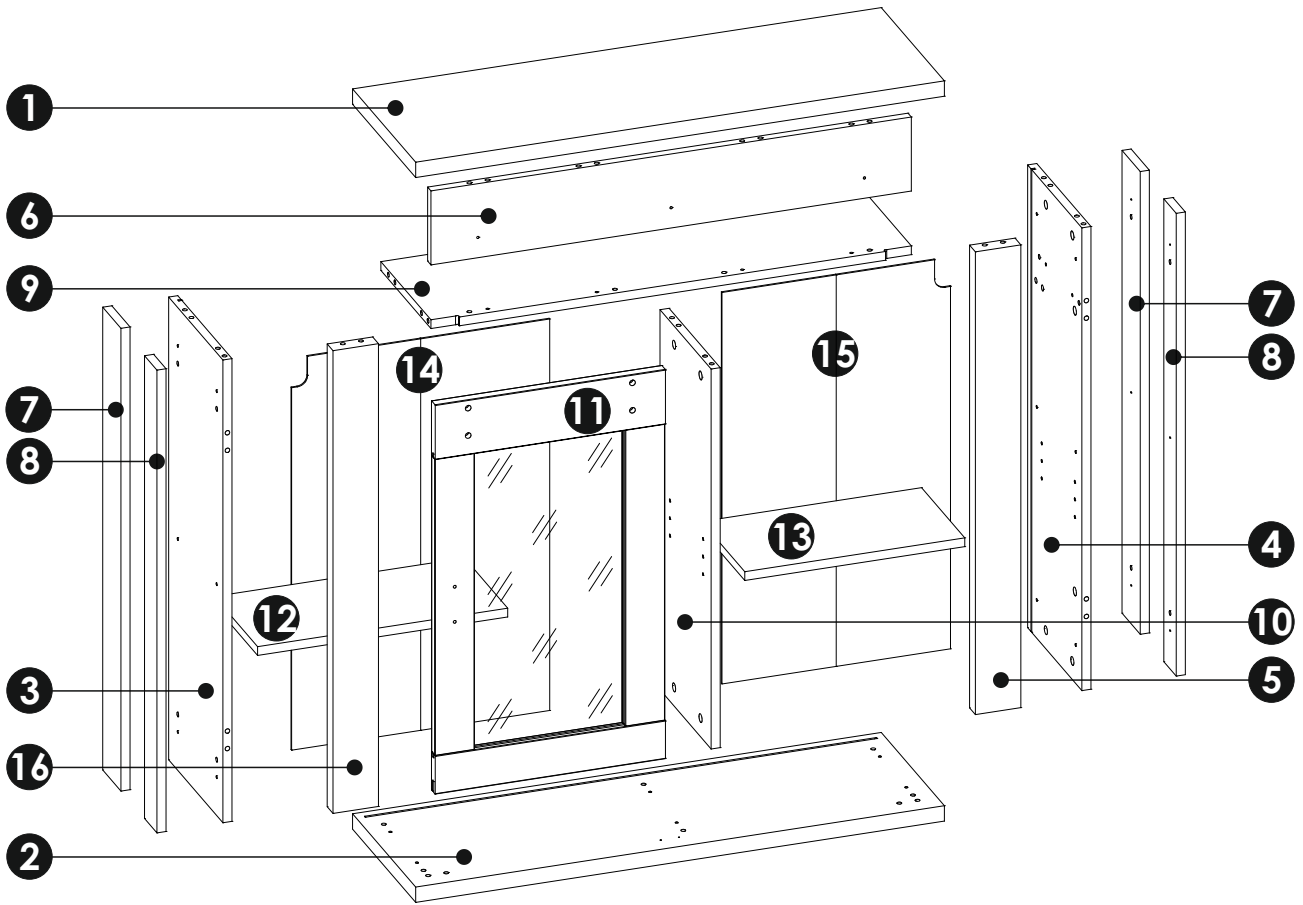
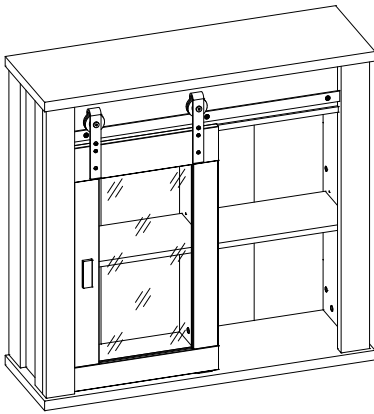

1	930	305	28	x1	1/2
2	930	305	28	x1	1/2
3	844	262	16	x1	2/2
4	844	262	16	x1	2/2
5	844	80	28	x1	1/2

6	845	135	16	x1	1/2
7	844	88	16	x2	2/2
8	844	60	16	x2	2/2
9	845	248	16	x1	1/2
10	693	247	16	x1	1/2

11	710	405	18	x1	2/2
12	440	209	16	x1	1/2
13	387	209	16	x1	1/2
14	714	454	3	x1	2/2
15	714	402	3	x1	1/2
16	844	80	28	x1	1/2



1 ▶

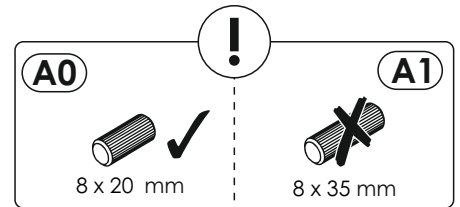
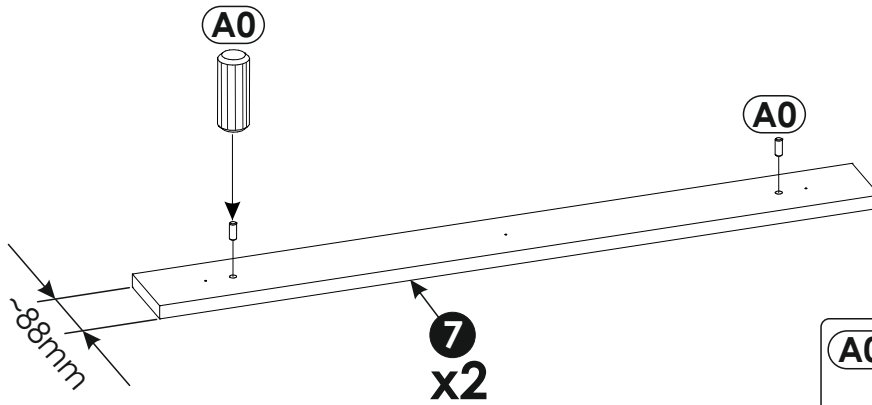
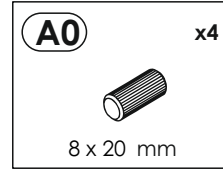
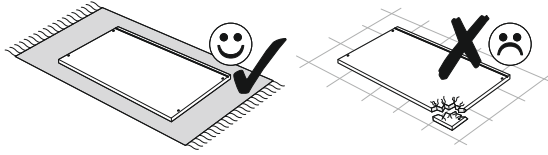

2 ▶

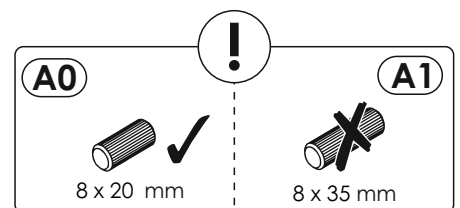
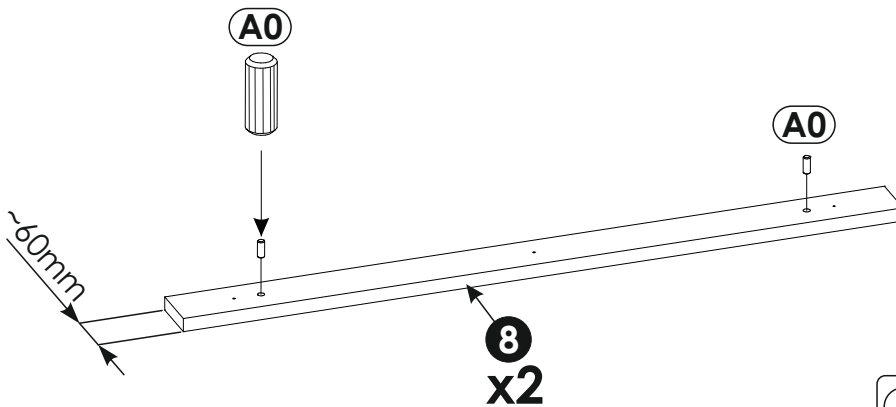
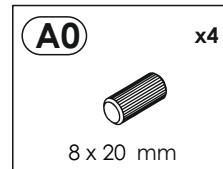
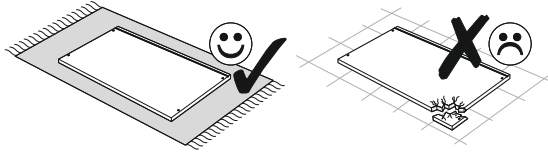

3 ▶

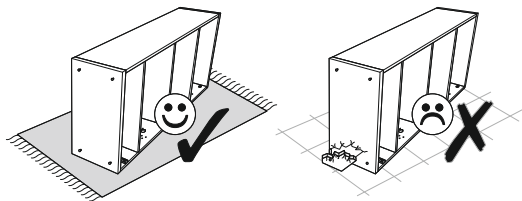

A1	x6	E1	x6	F1	x2
8 x 35 mm		15 x 12 mm		6 x 34 mm	

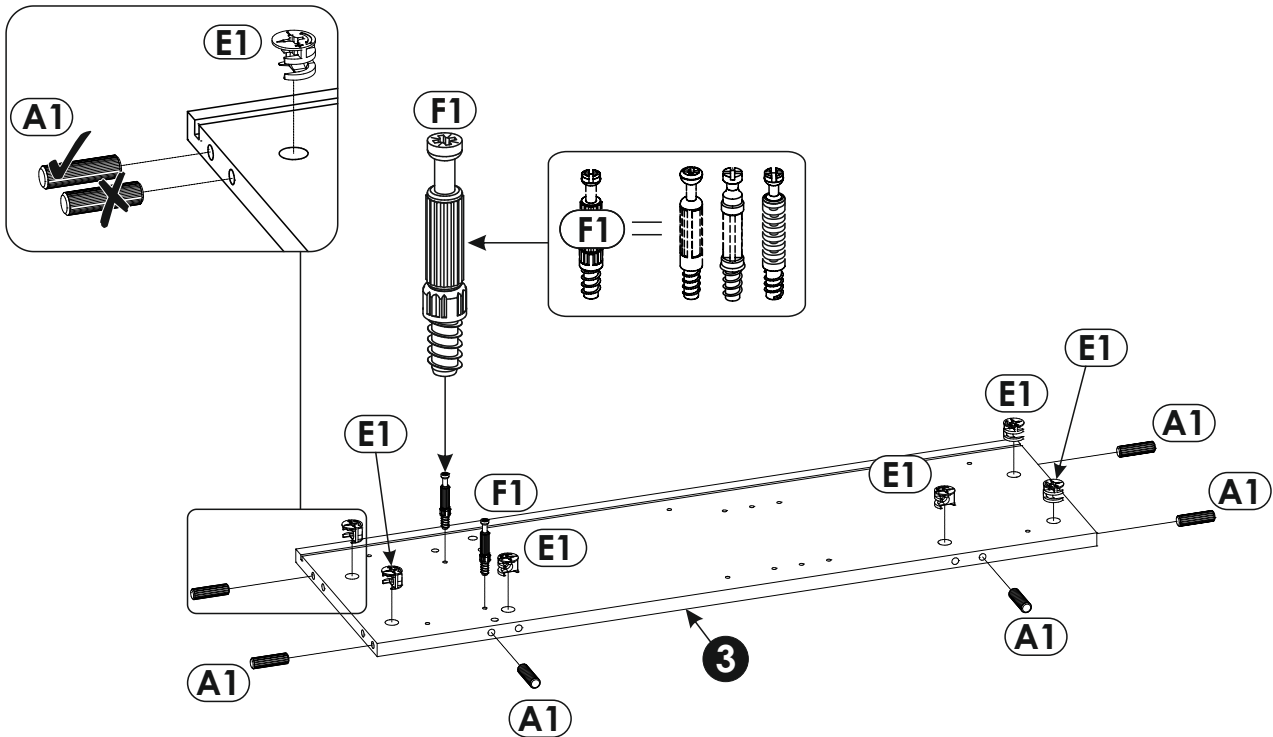

4 ▶

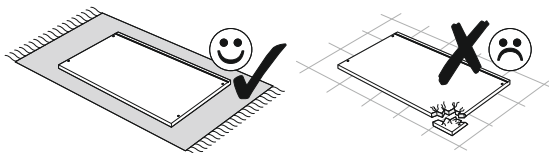

P9A	L	x1

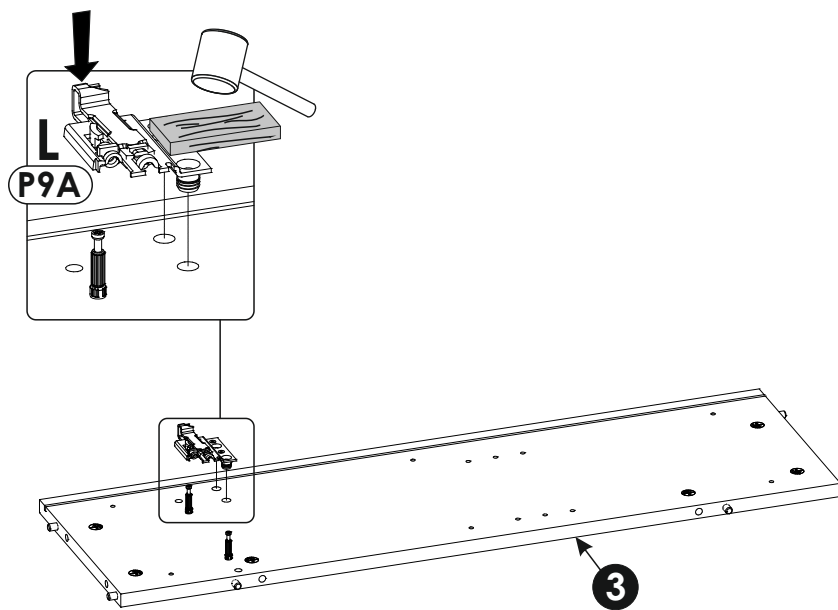

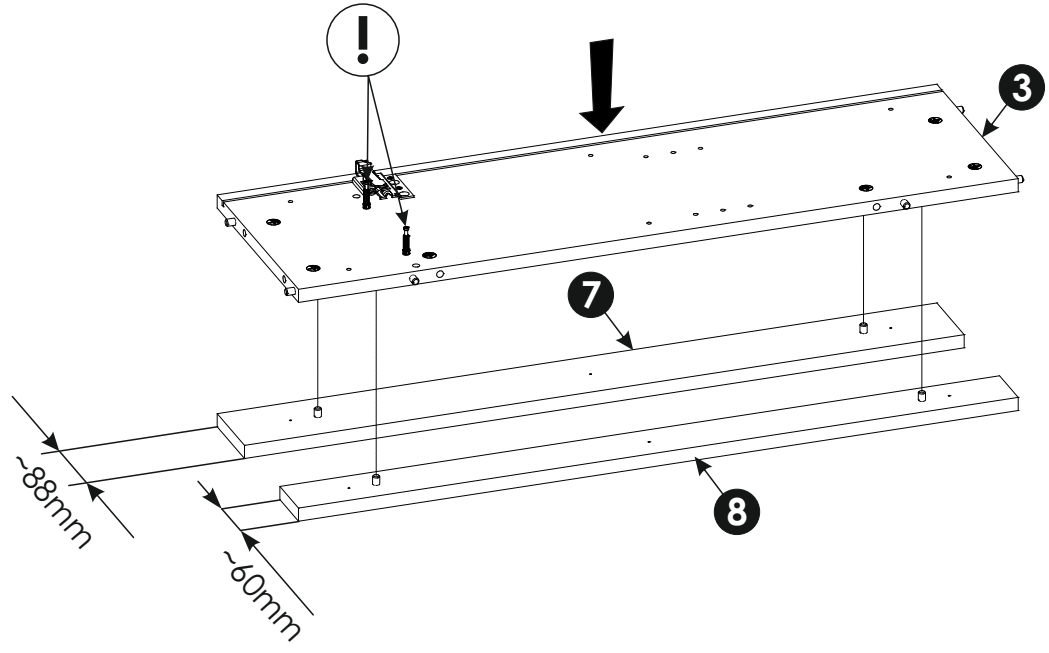
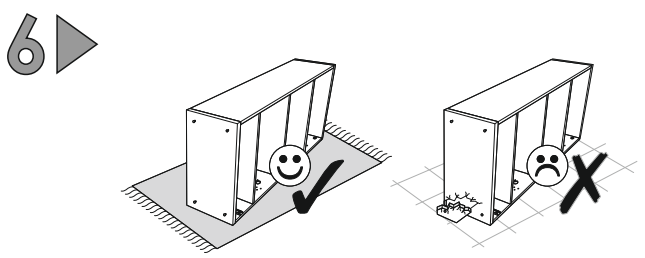
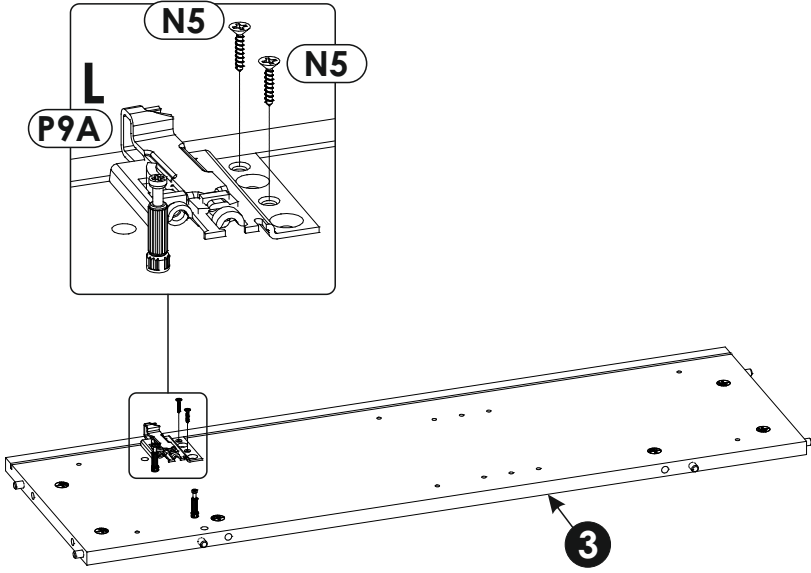
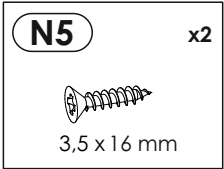
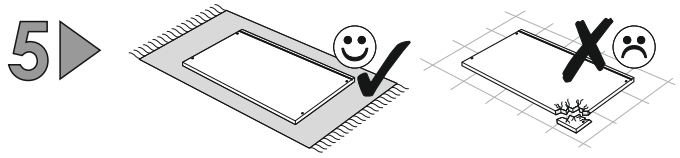

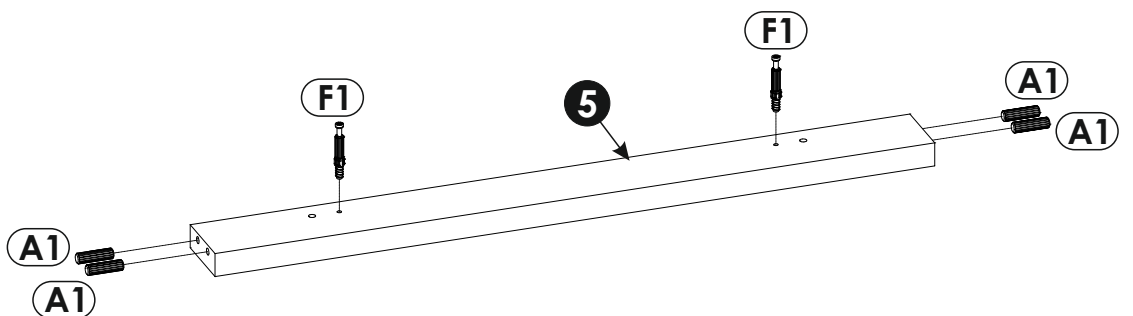
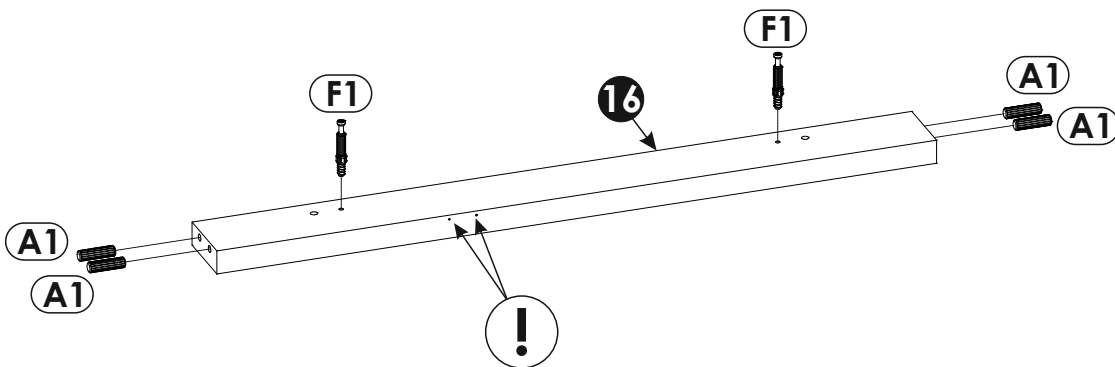
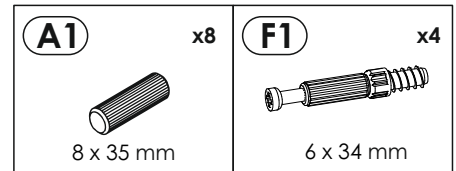
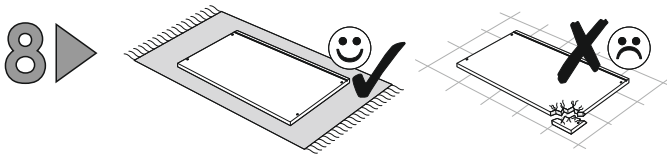
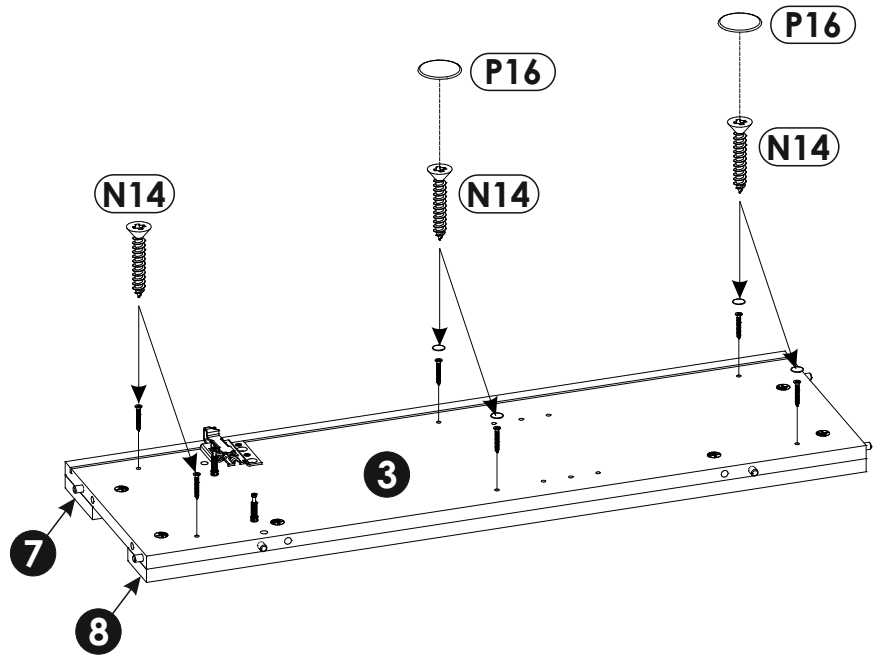
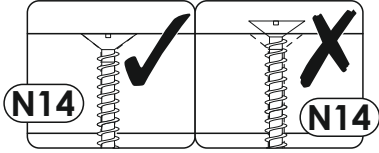
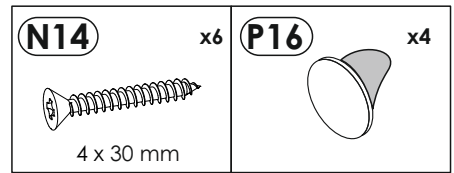
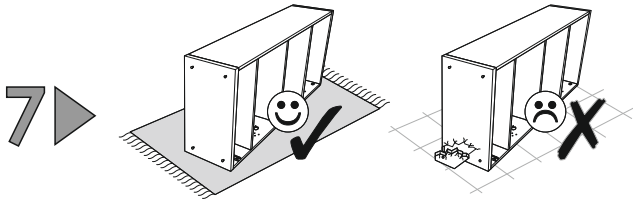

9 ▶

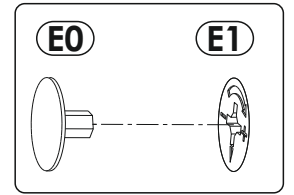
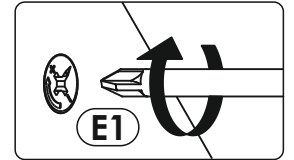
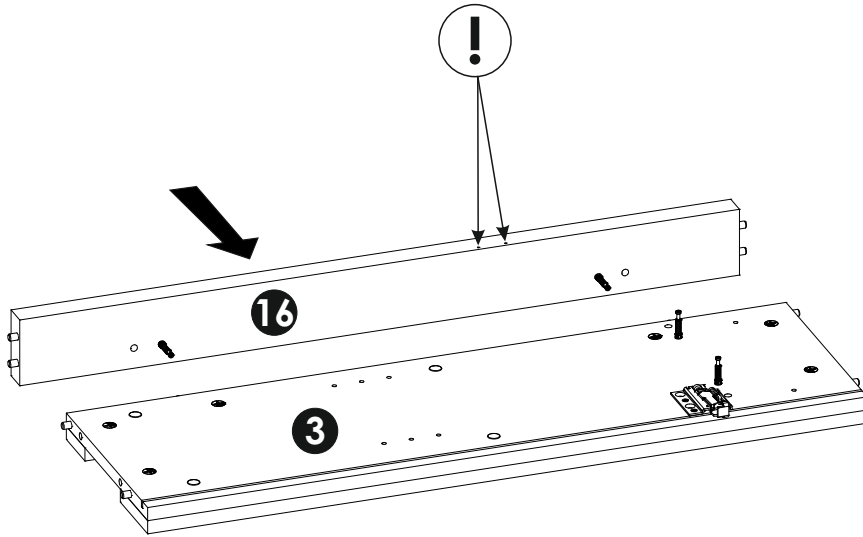
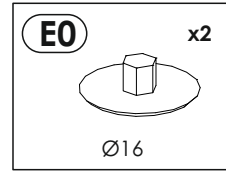
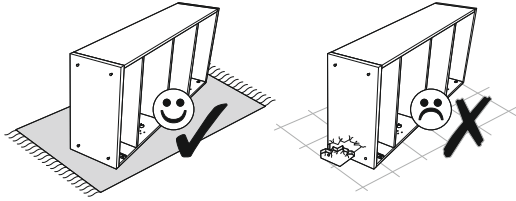

10 ▶

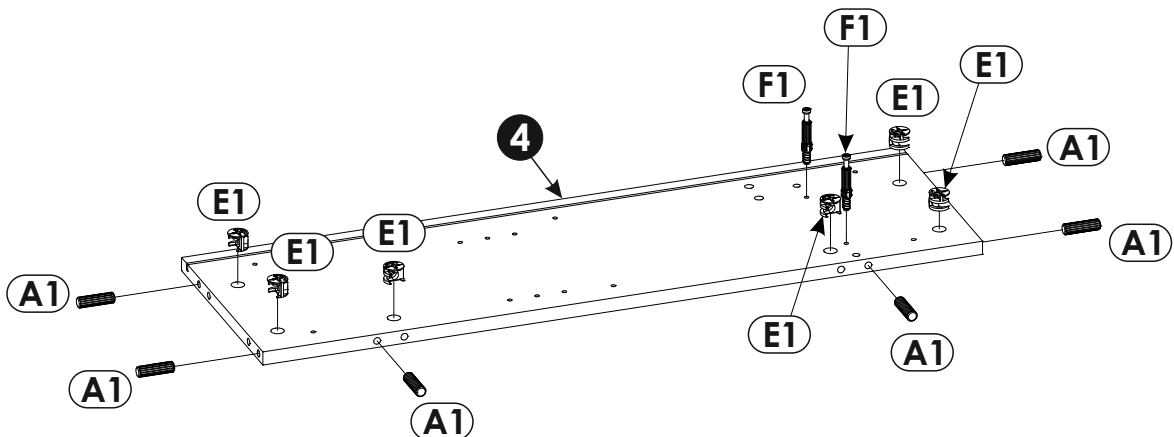
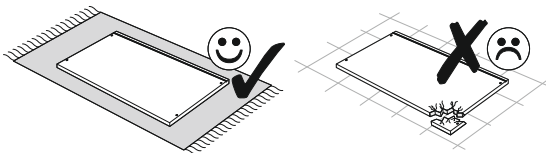

11 ▶

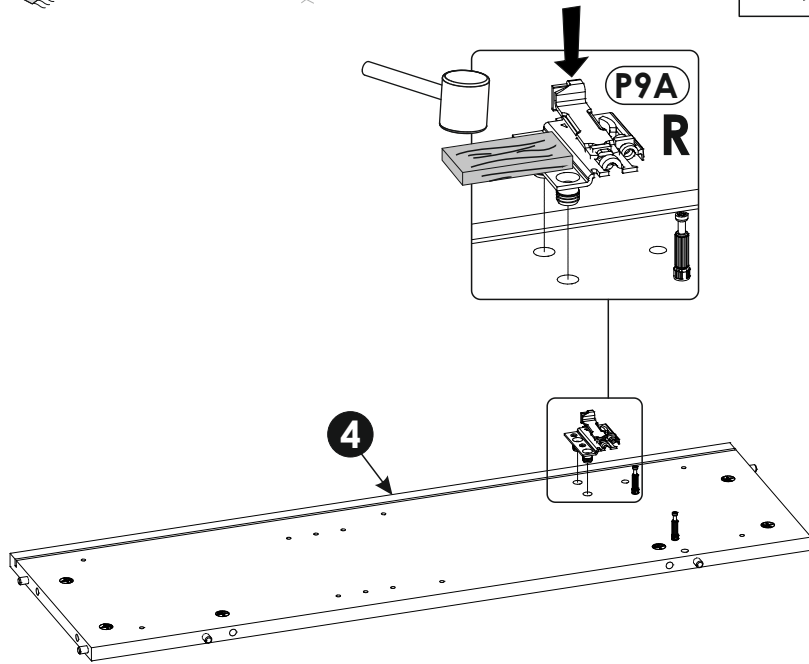
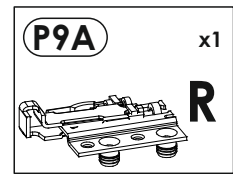
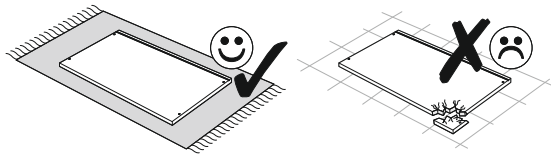

12 ▶

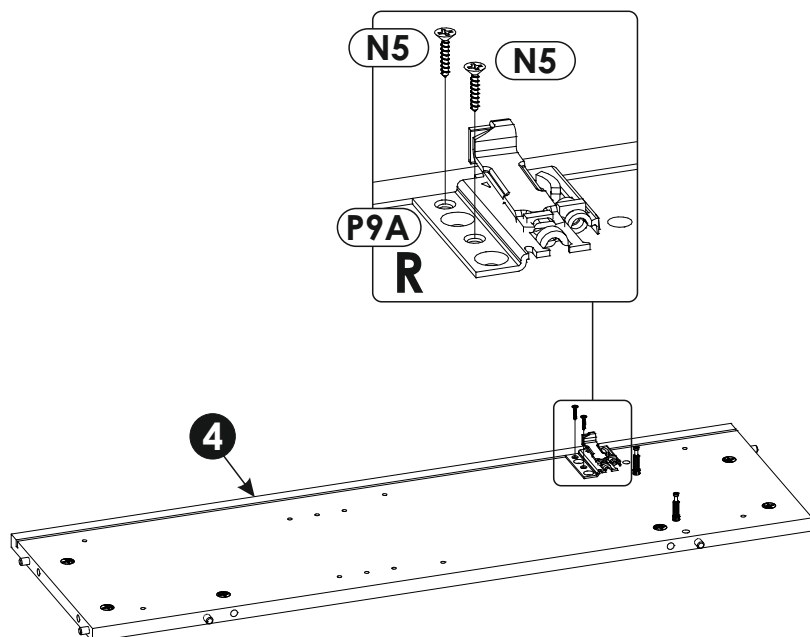
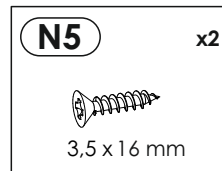
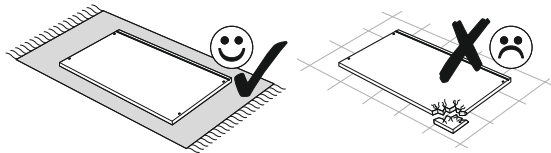

13 ▶

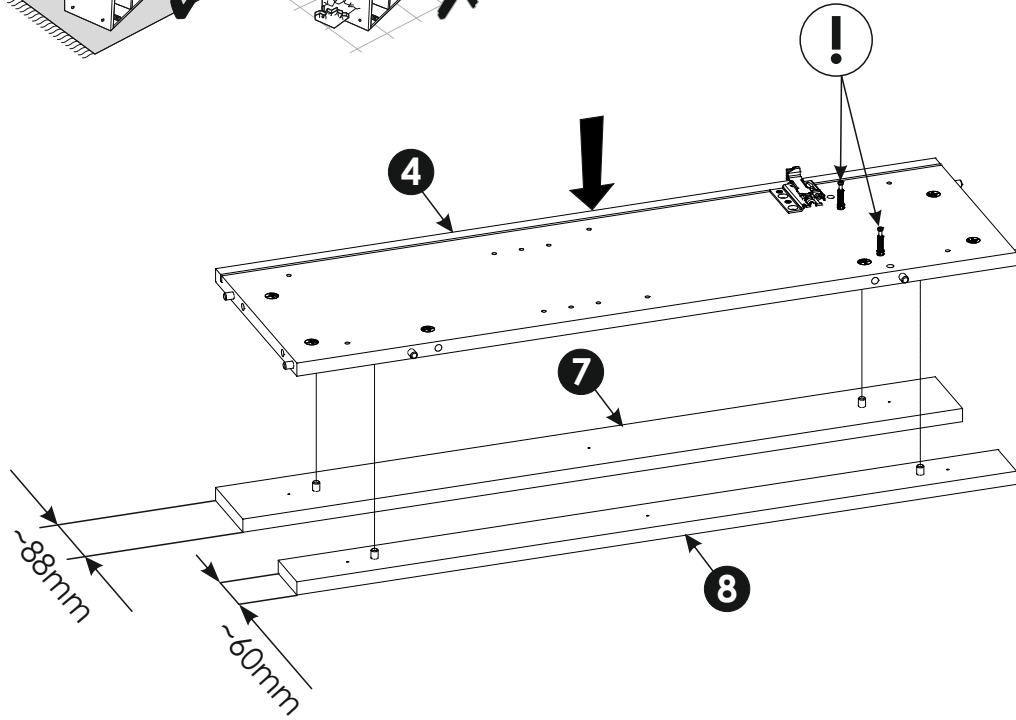
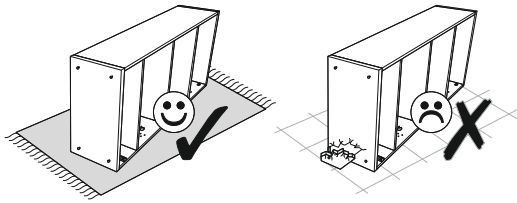

14 ▶

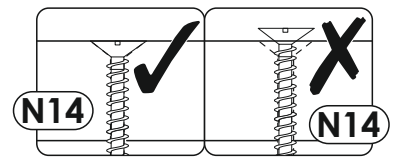
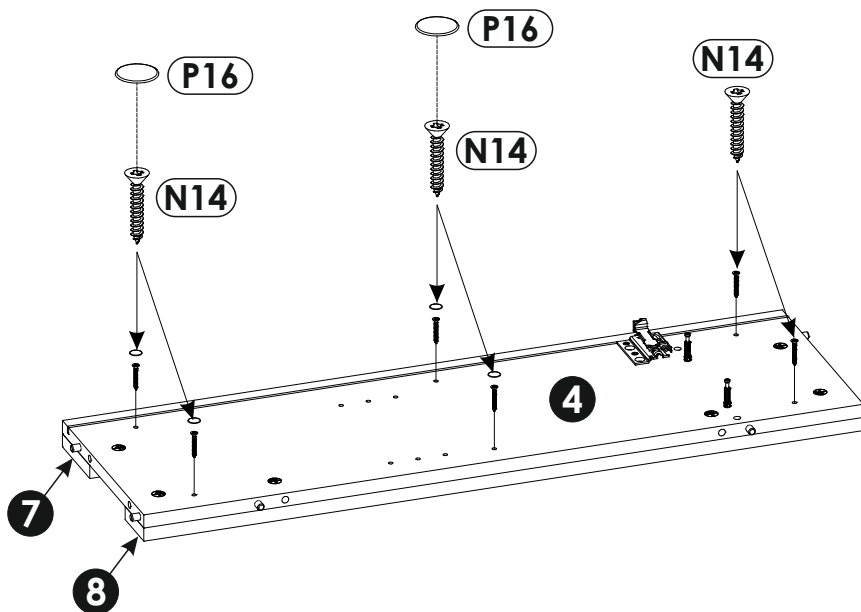
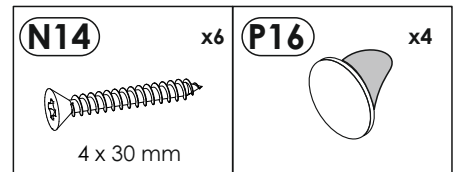
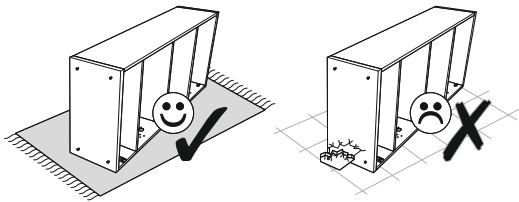

15 ▶

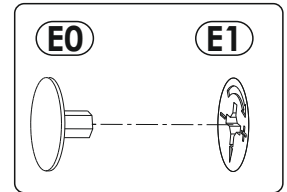
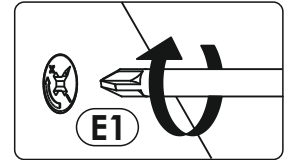
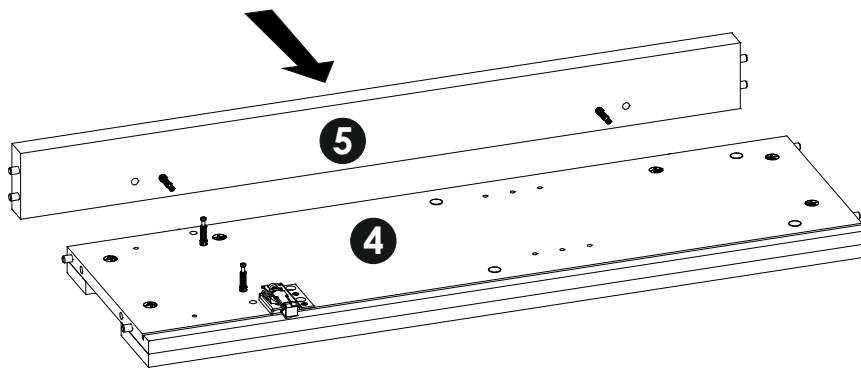
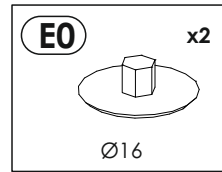
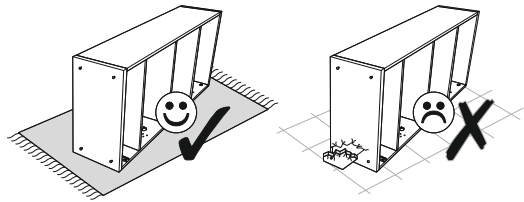

16 ▶

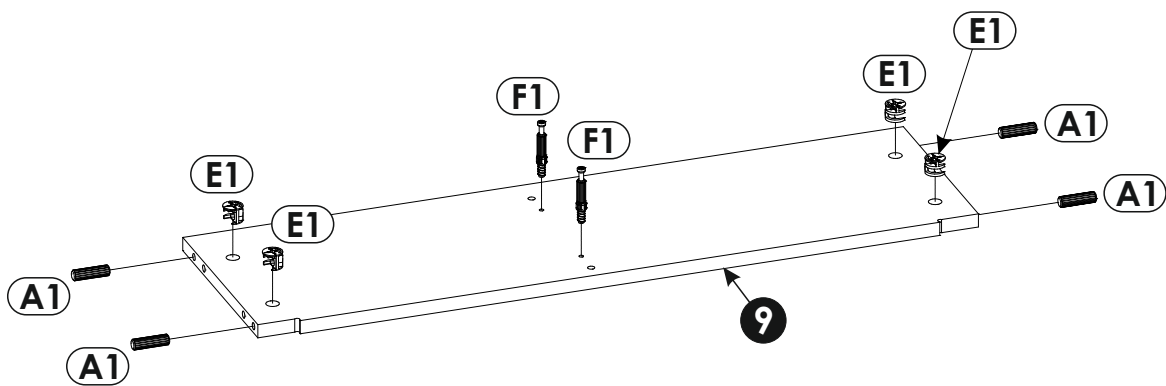
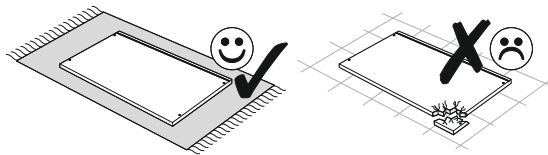

17 ▶

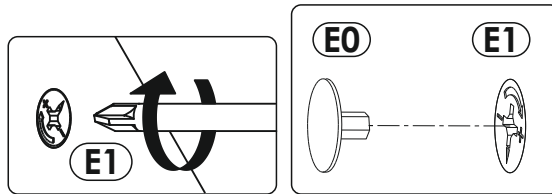
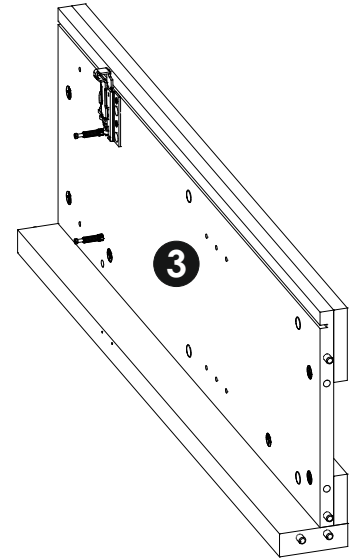
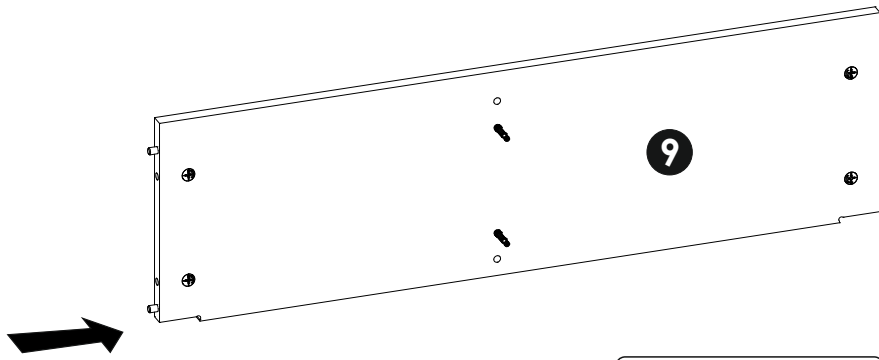
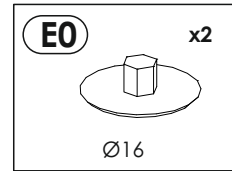
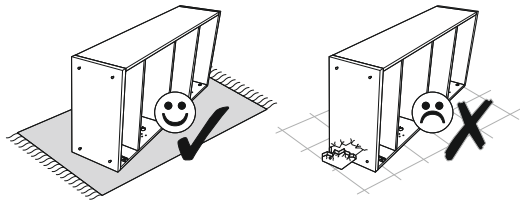

18 ▶

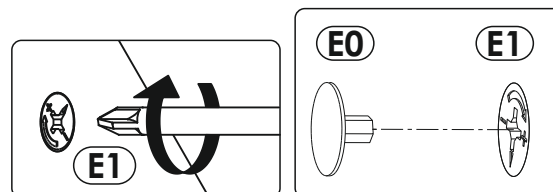
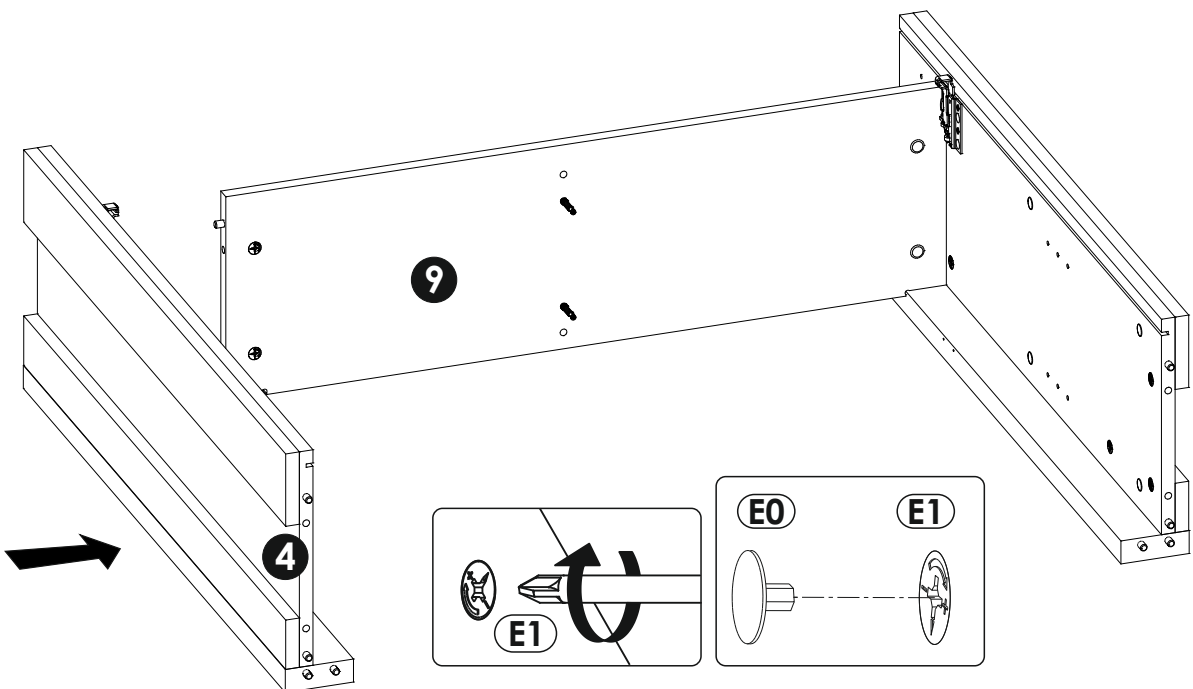
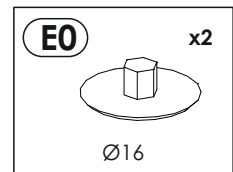
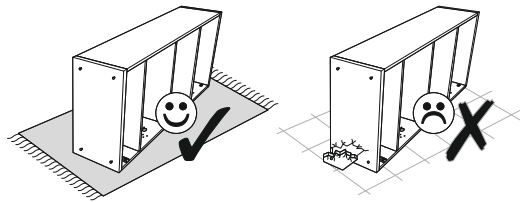

19 ▶

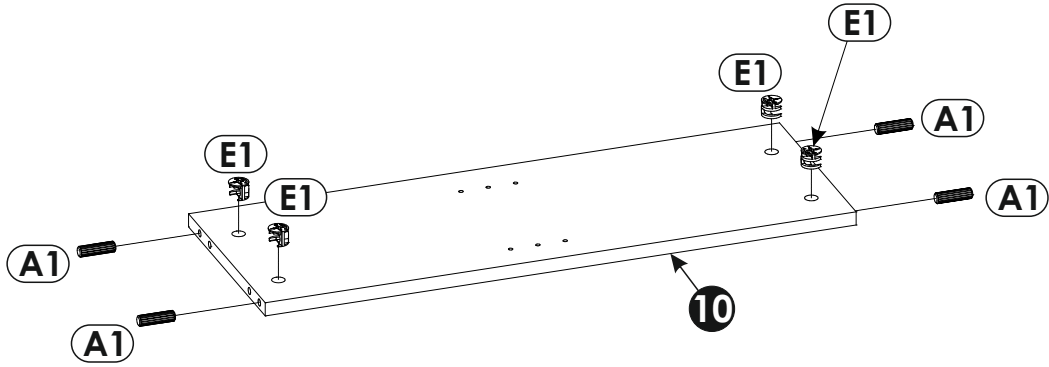
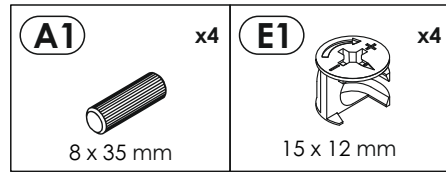
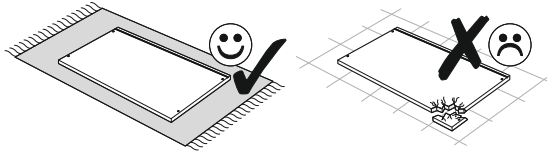

20 ▶

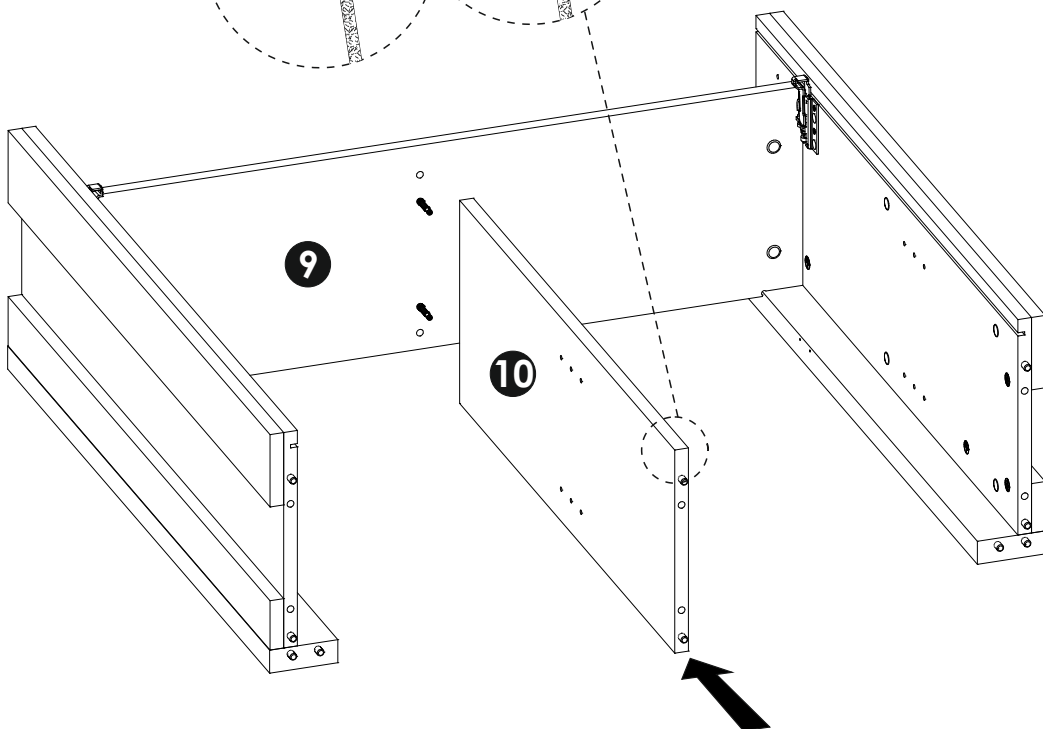
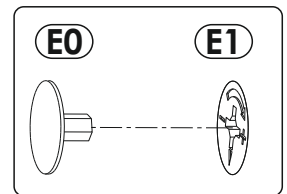
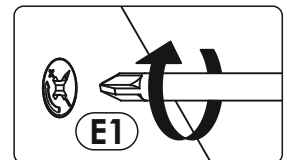
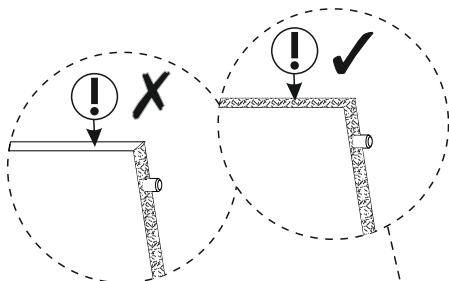
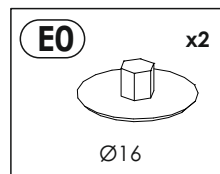
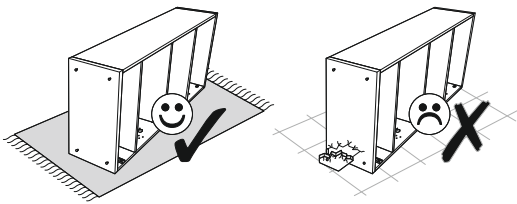

21 ▶▶

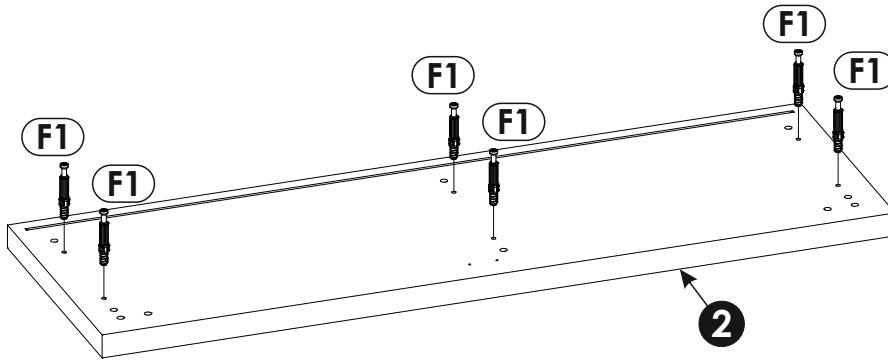
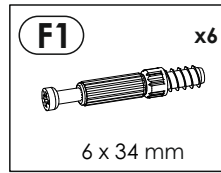
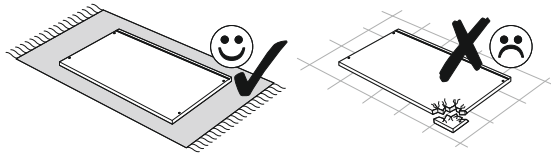

22 ▶▶

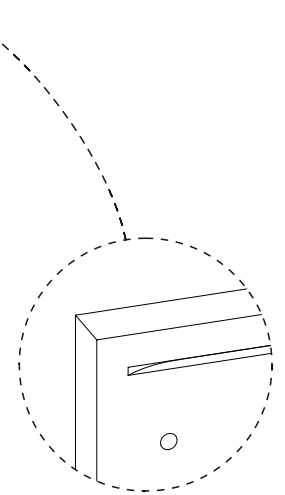
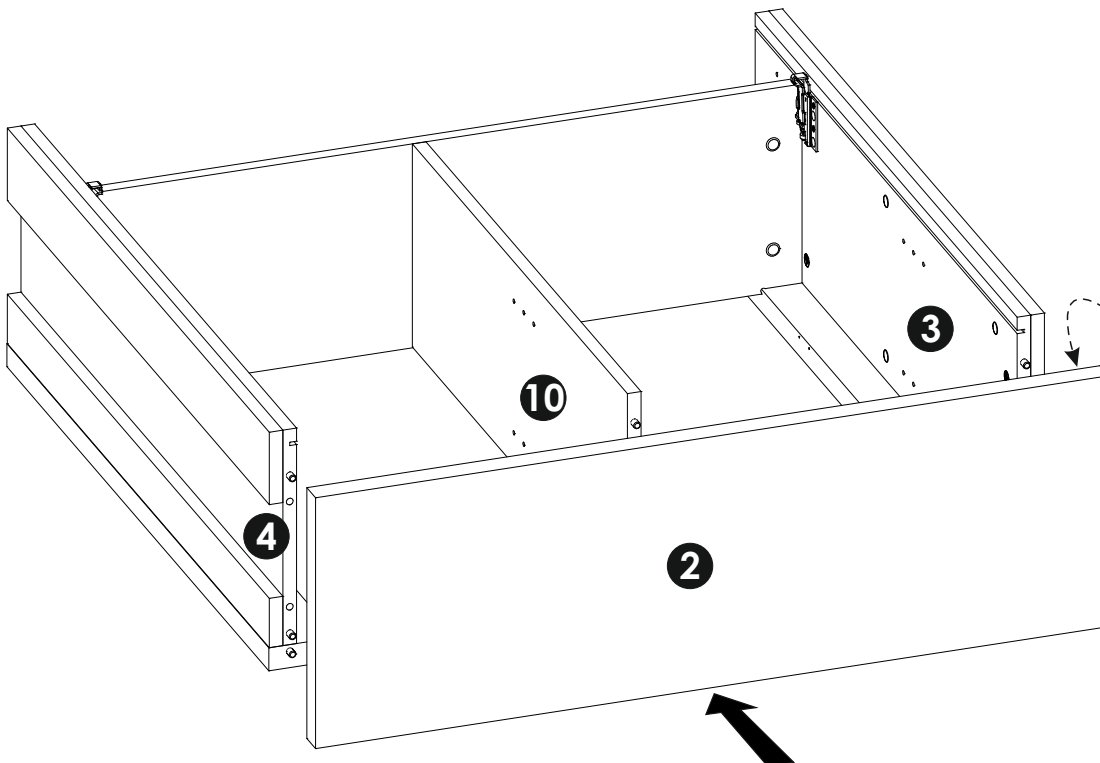
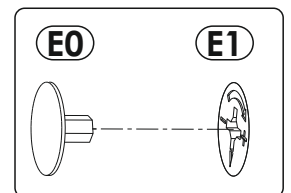
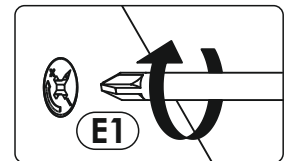
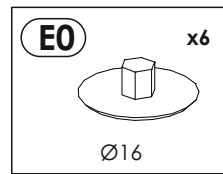
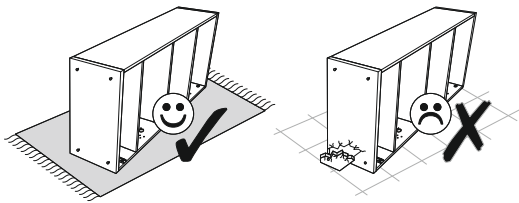

23 ▶

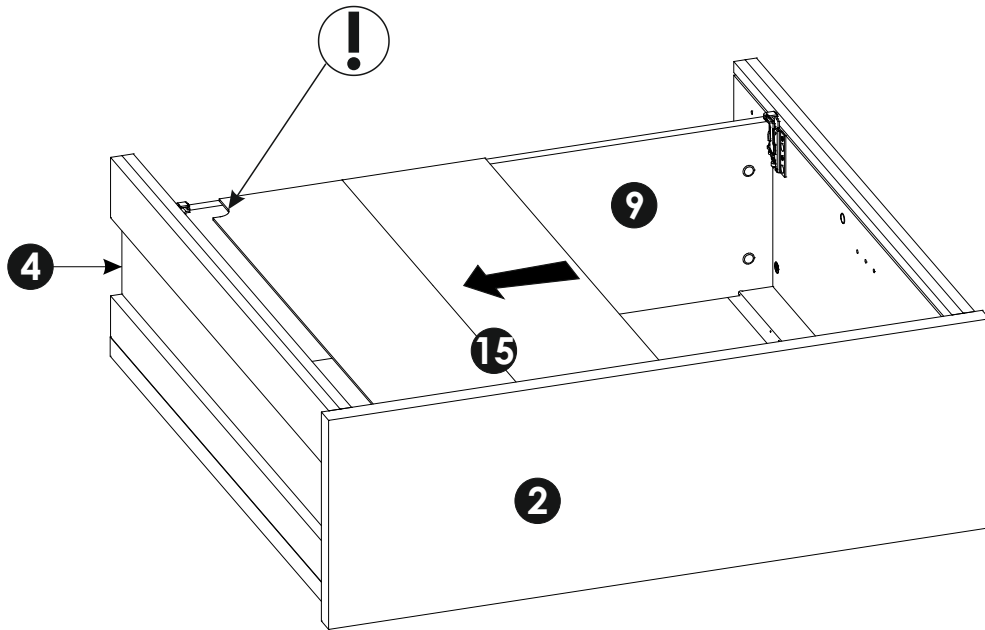
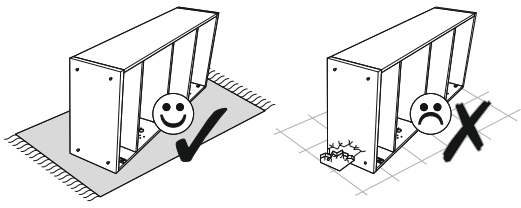

24 ▶

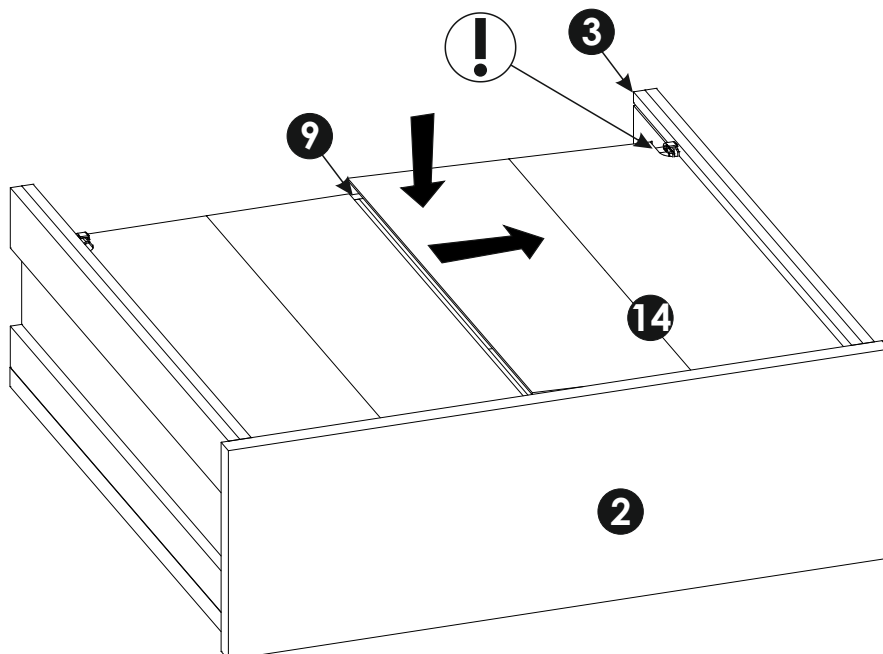
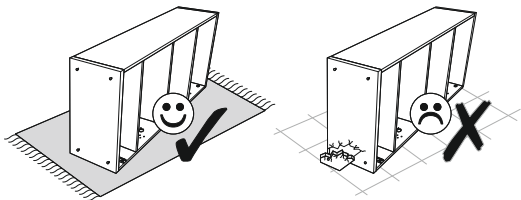

25 ▶

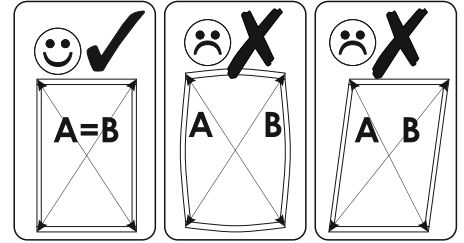
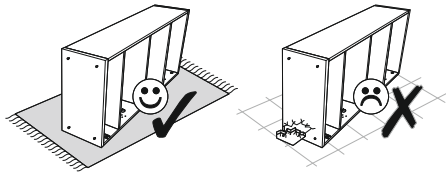

A=B

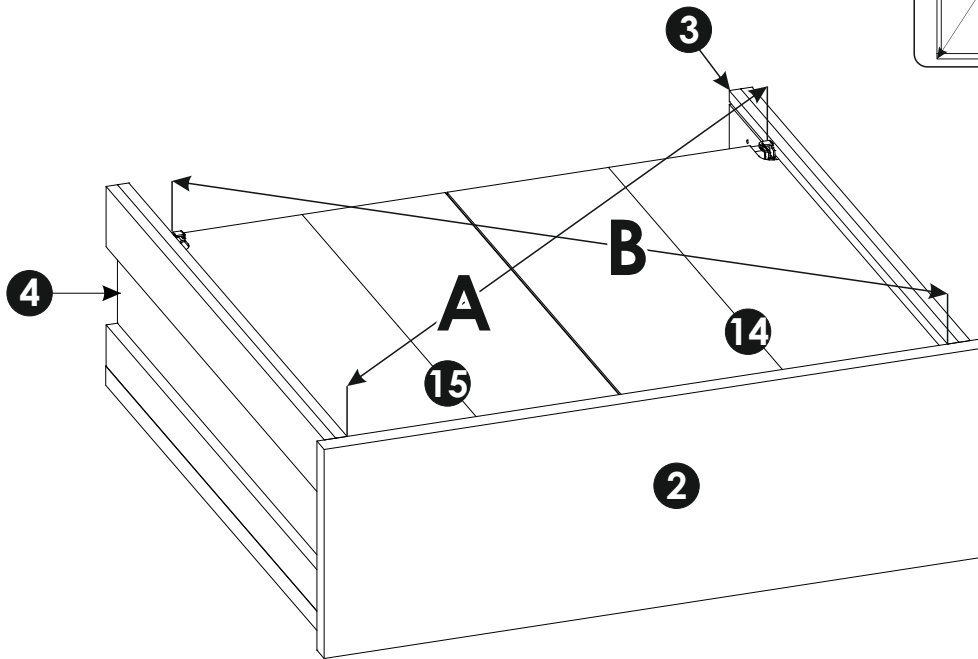

26 ▶

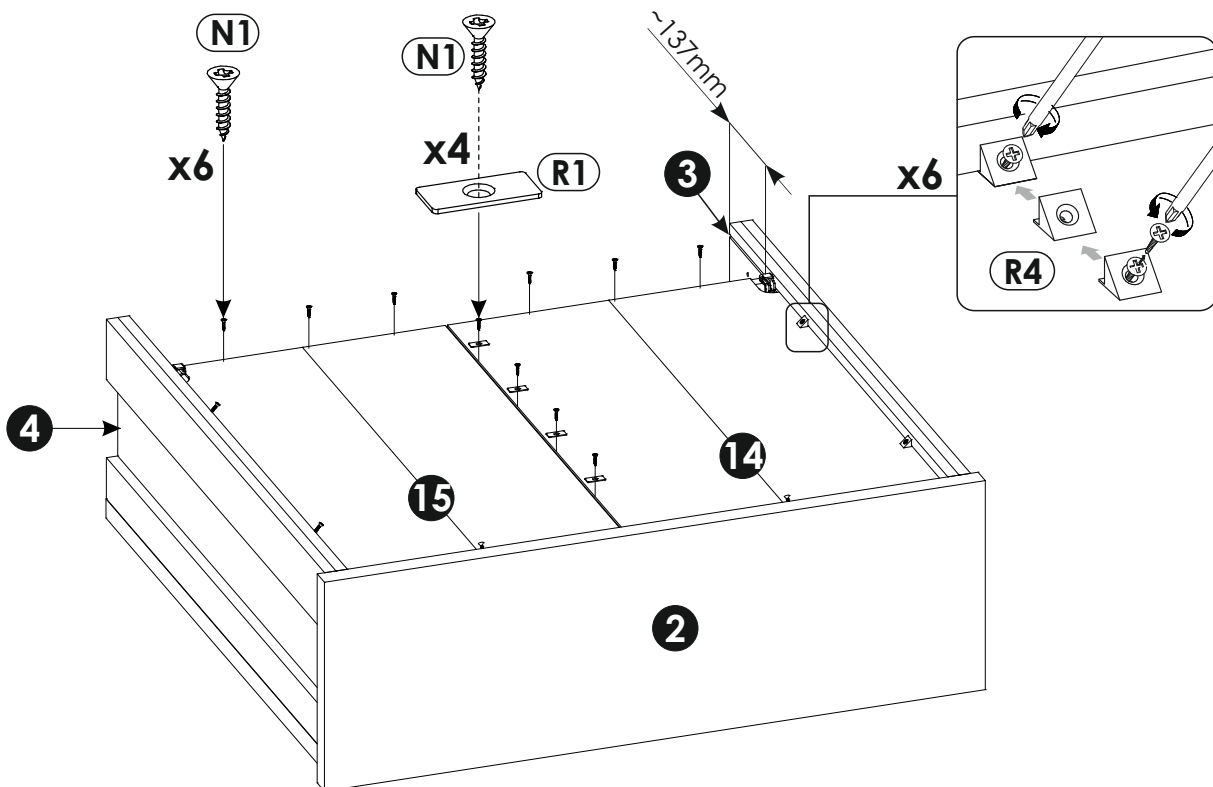
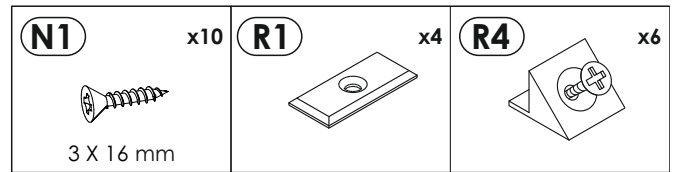
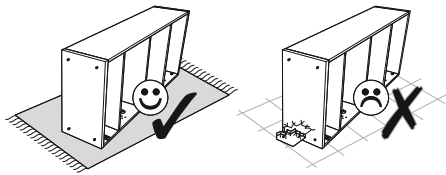

27 ▶

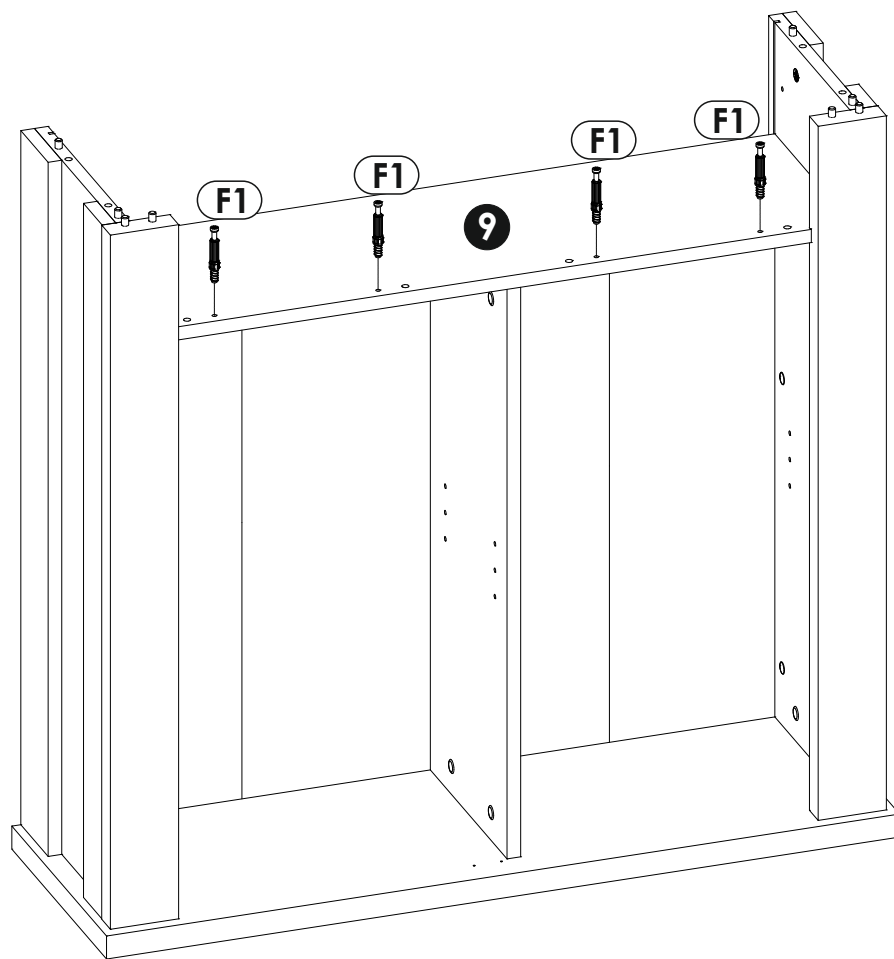
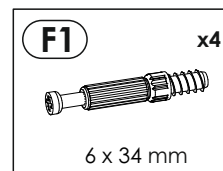
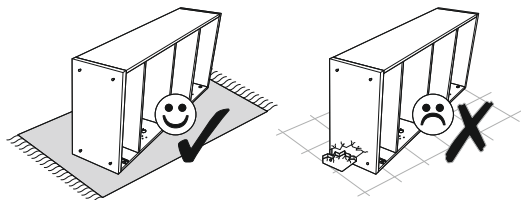

28 ▶

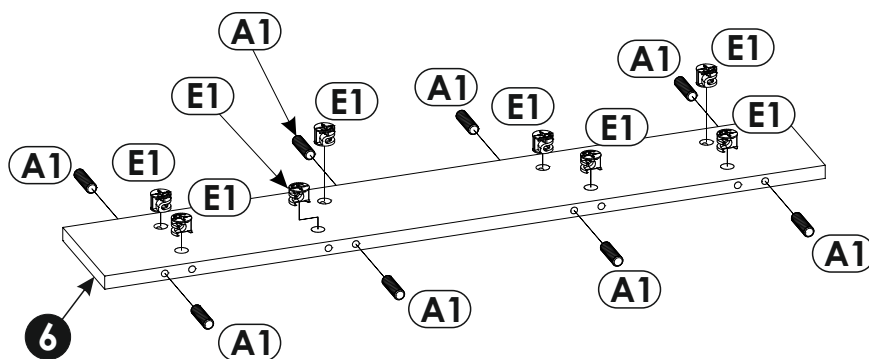
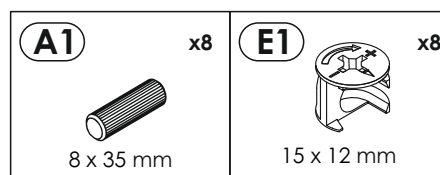
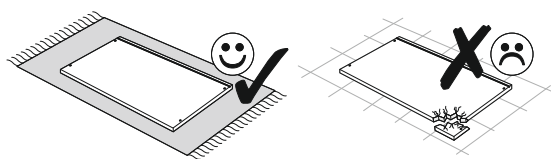

29 ▶

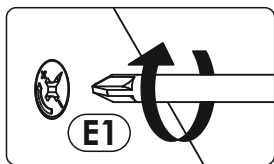
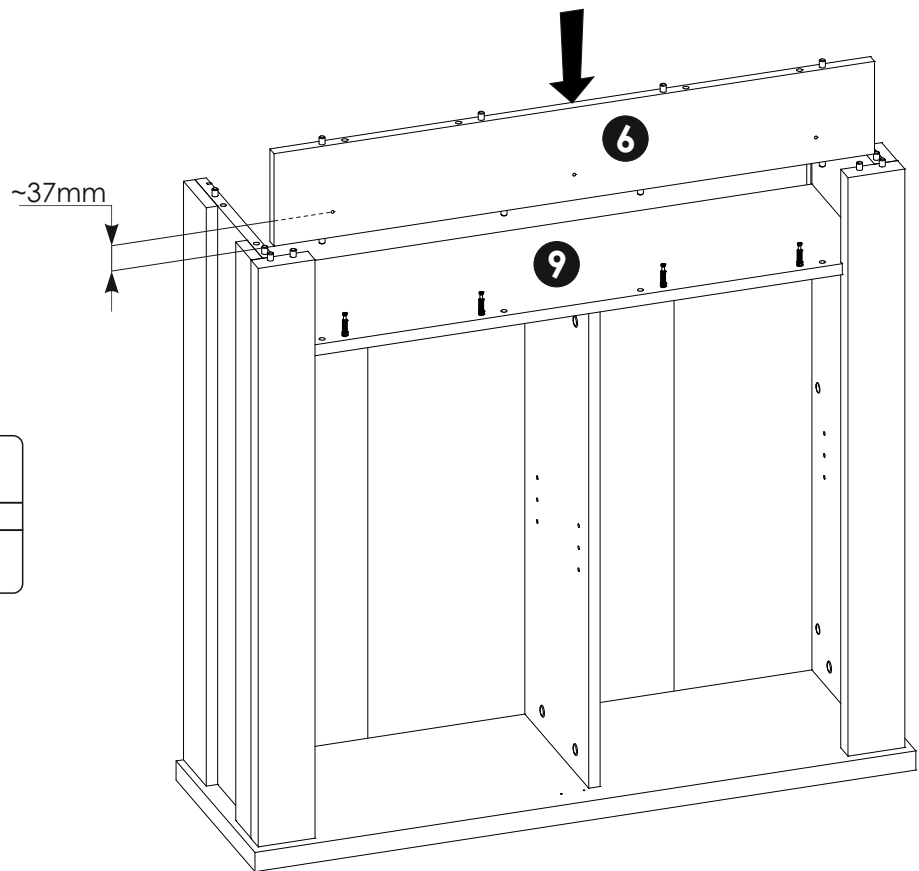
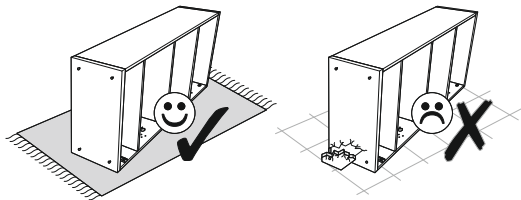

30 ▶

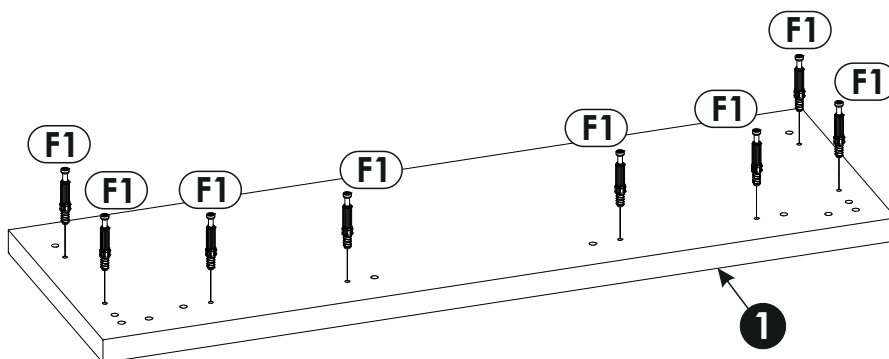
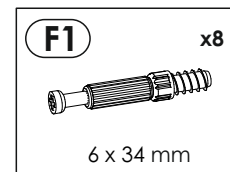
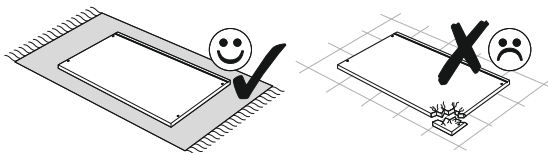

31 ▶

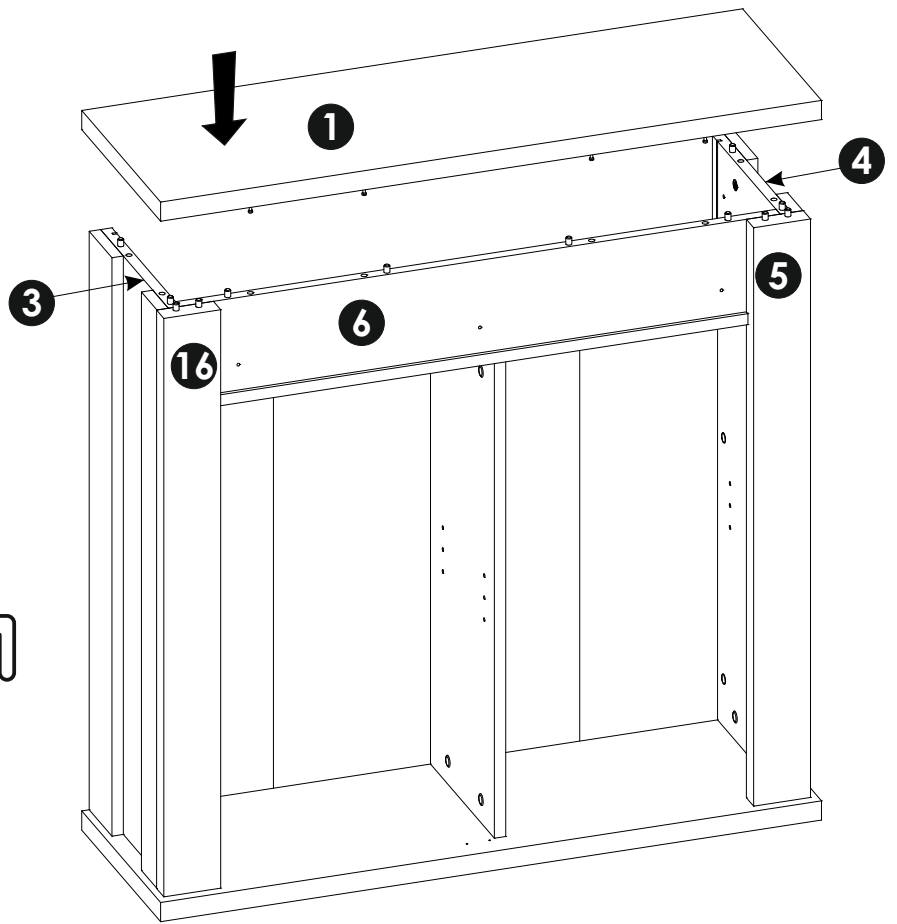
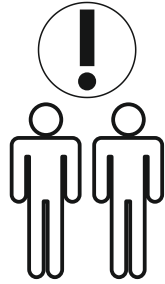
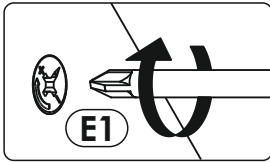
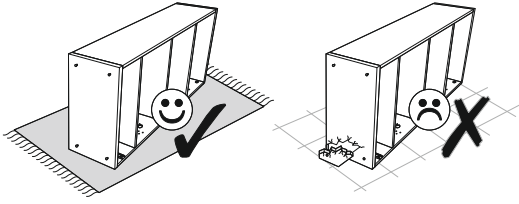



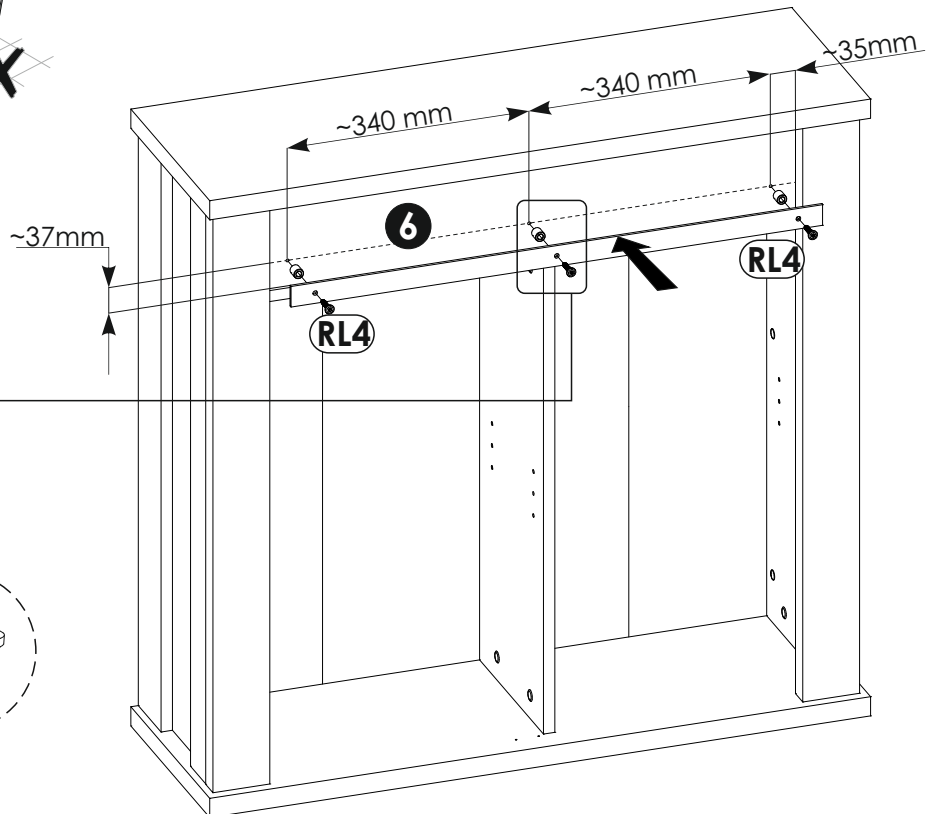
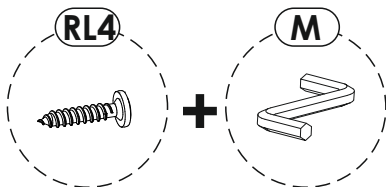
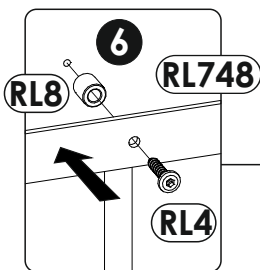
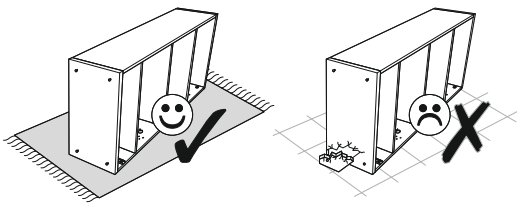

32 ▶

RL4	x3	RL8	x3	RL748	x1
					BE SC 07 48 00

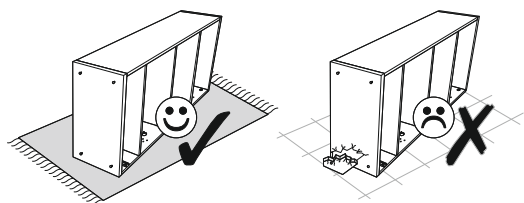

33 ▶

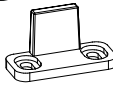

I0	x2	R10	x1	RL2	x2	RL7	x1
							
3 x 13 mm							

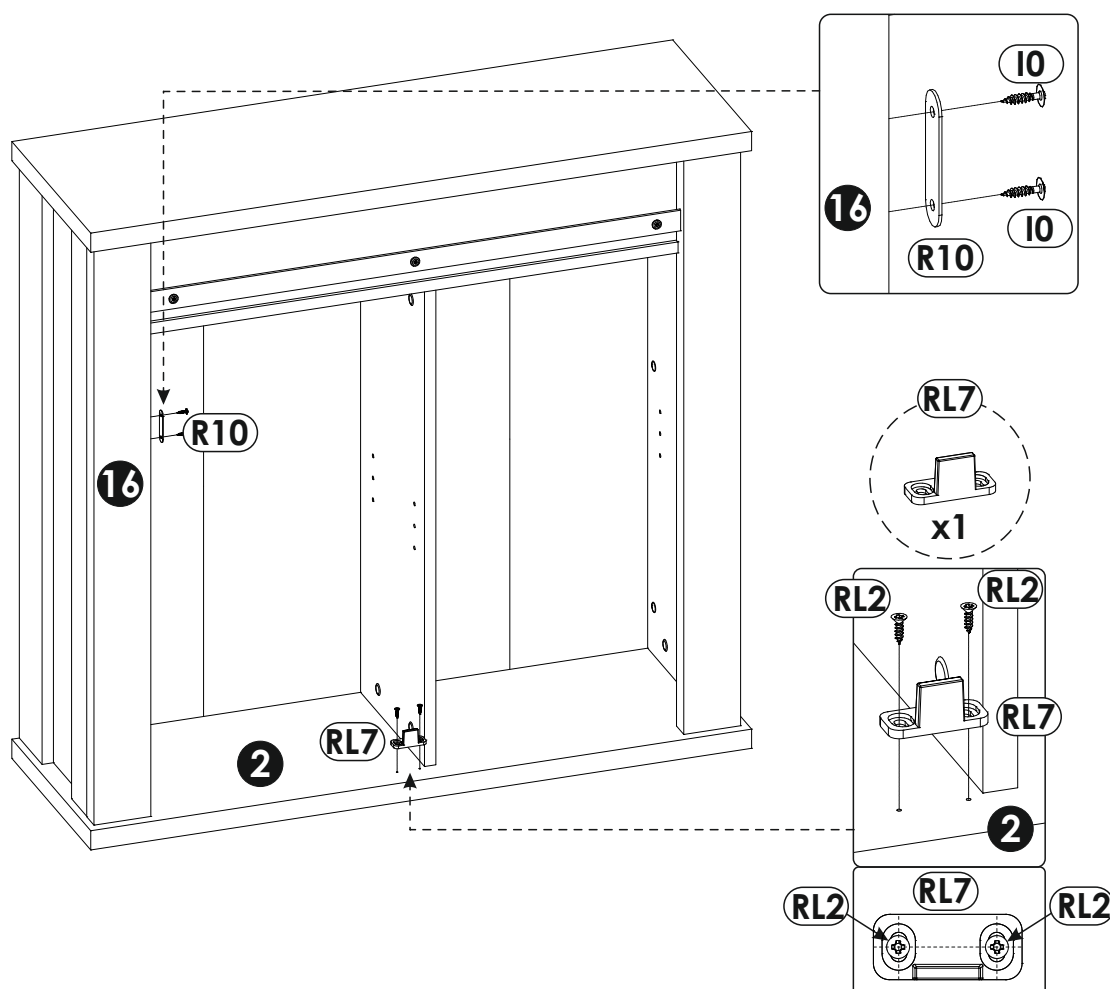

34 ▶

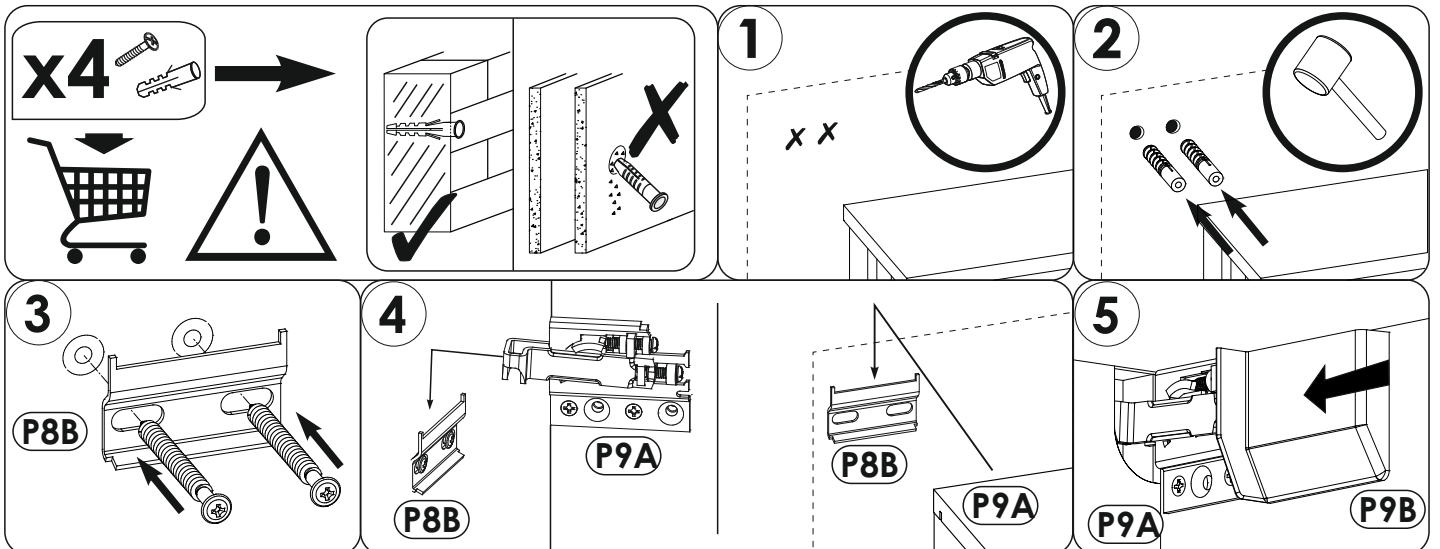
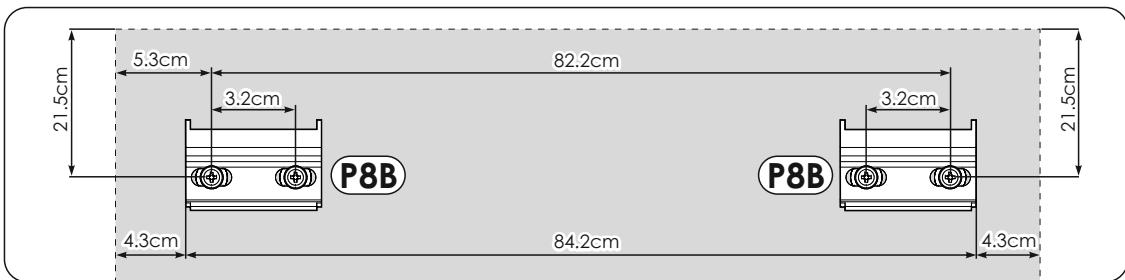
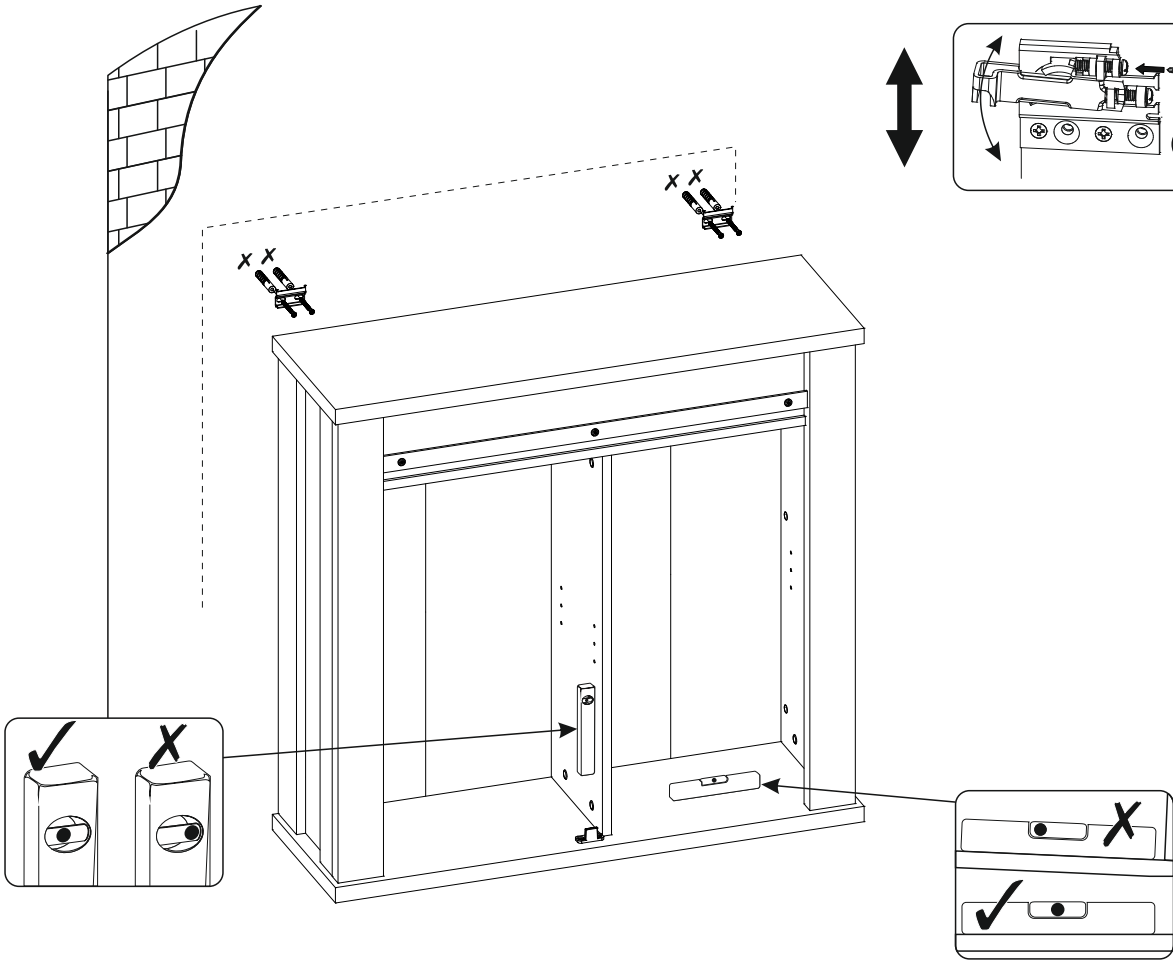
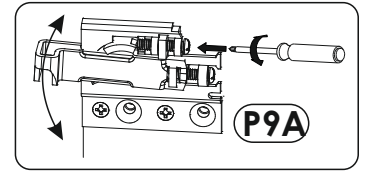
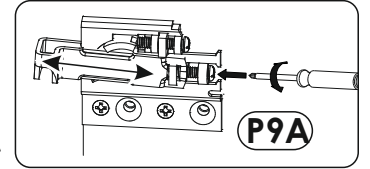
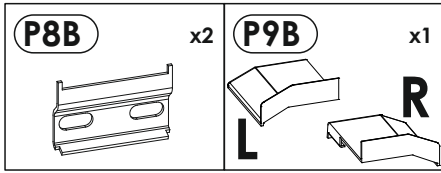

35 ▶

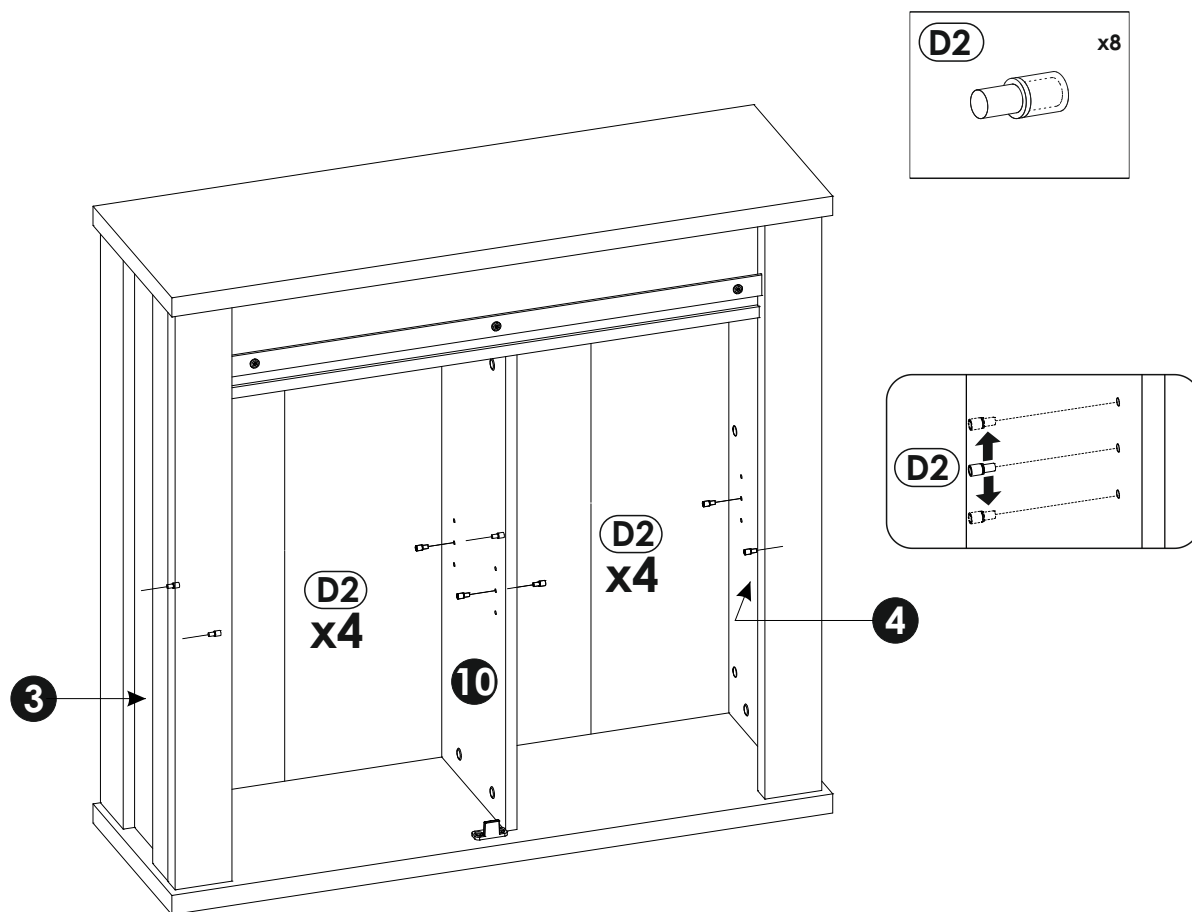

36 ▶

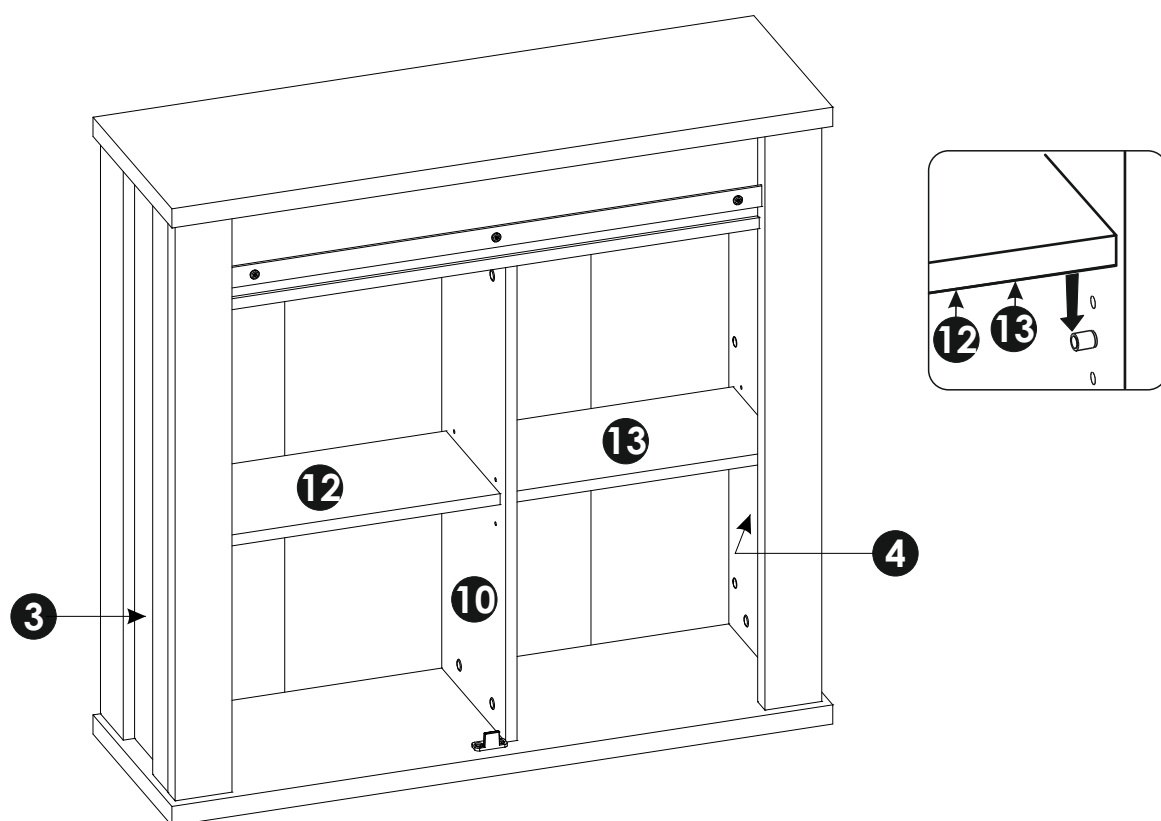

37▶

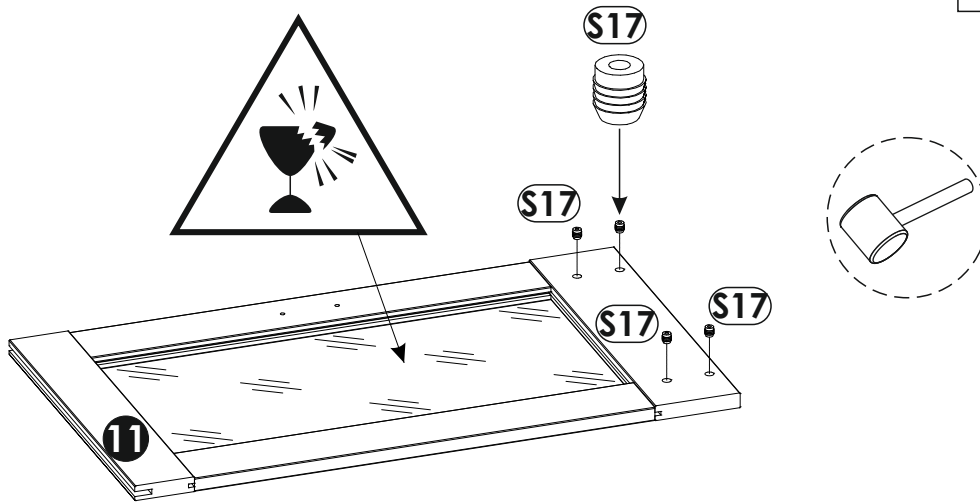
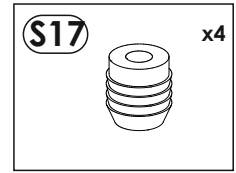
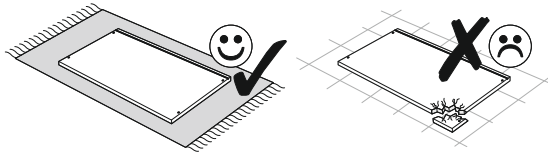

38▶

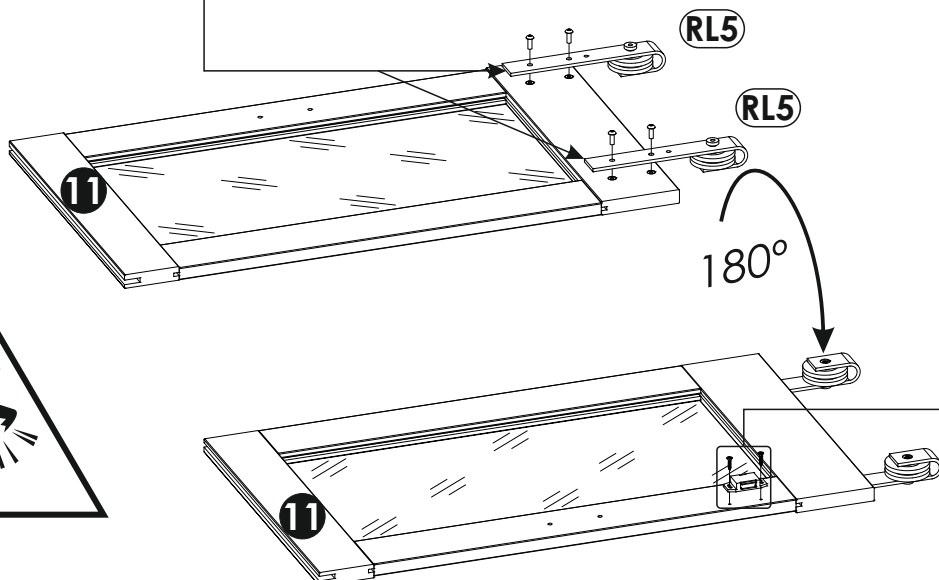
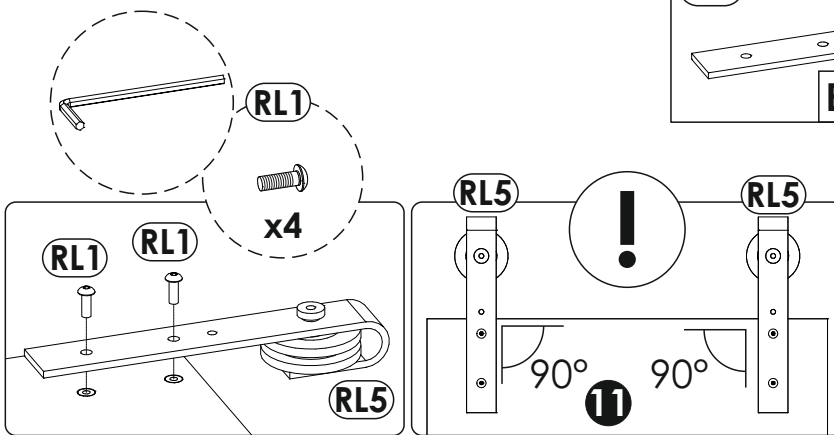
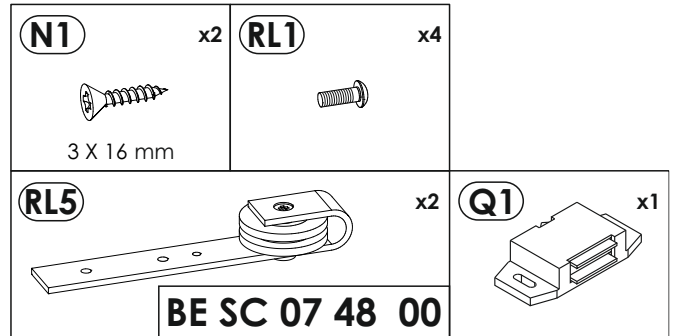
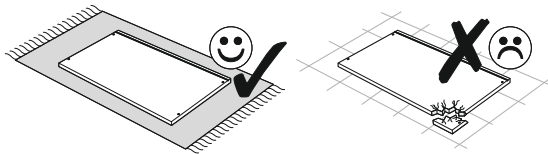

39▶

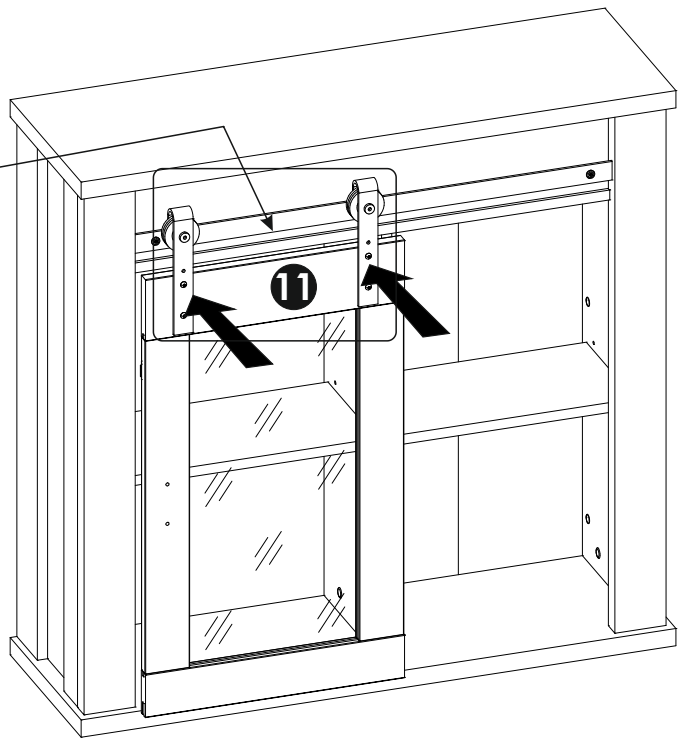
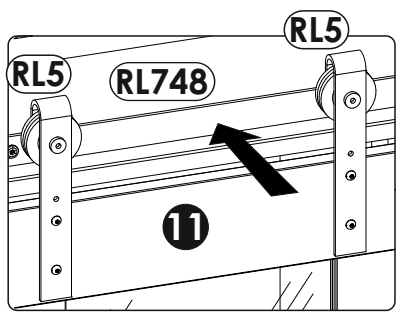

40▶

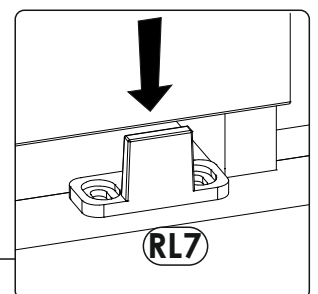
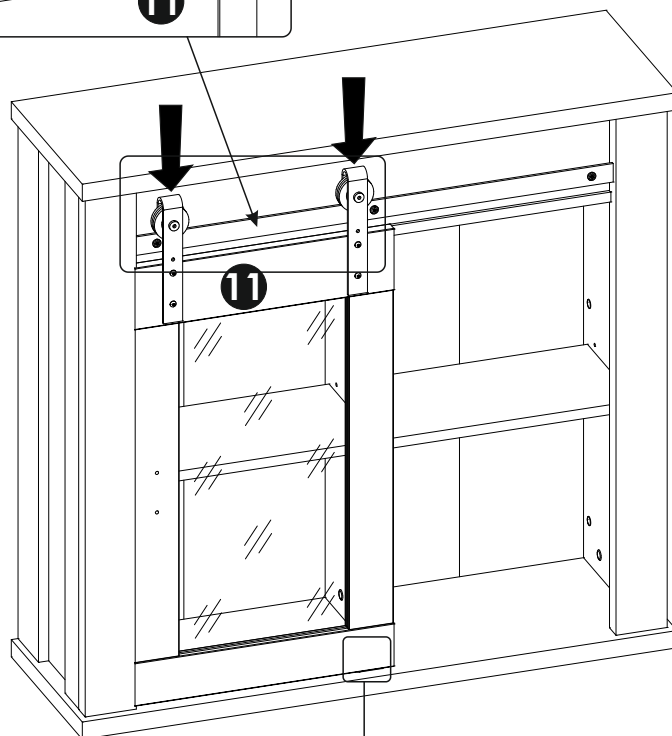
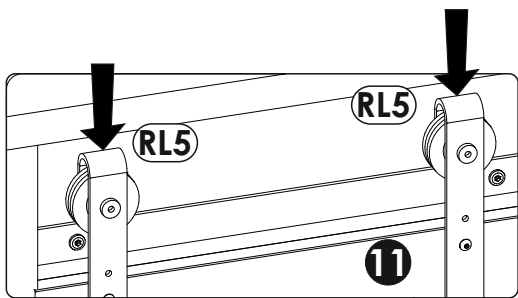

41 ▶

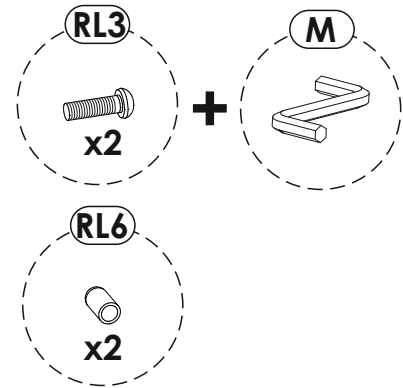
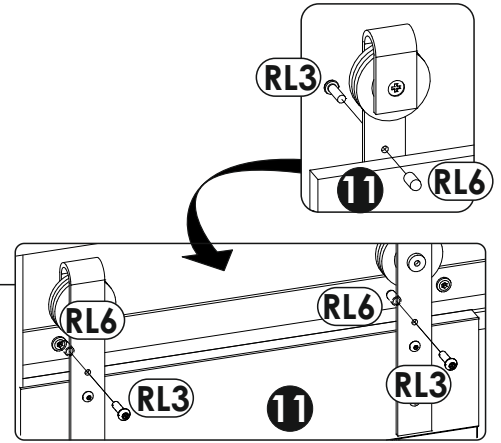
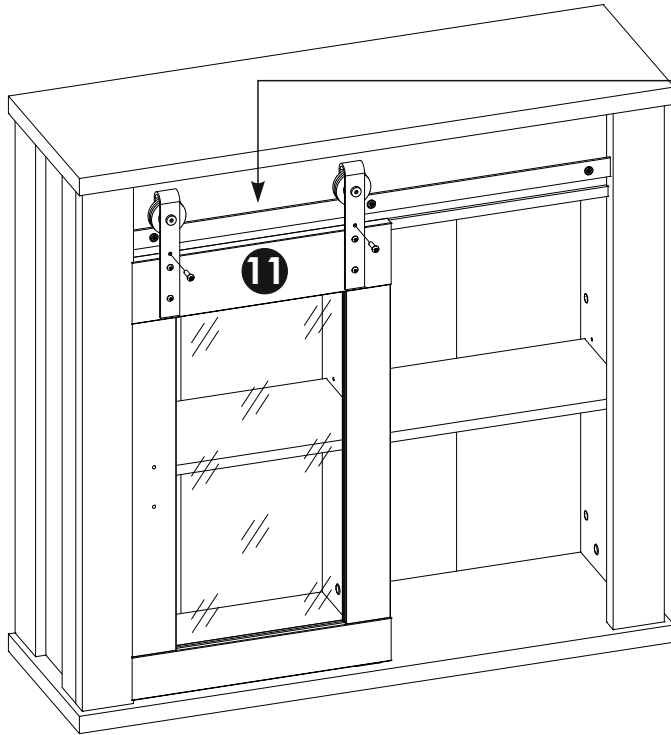
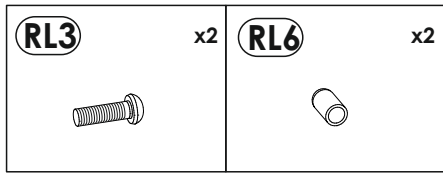

42 ▶

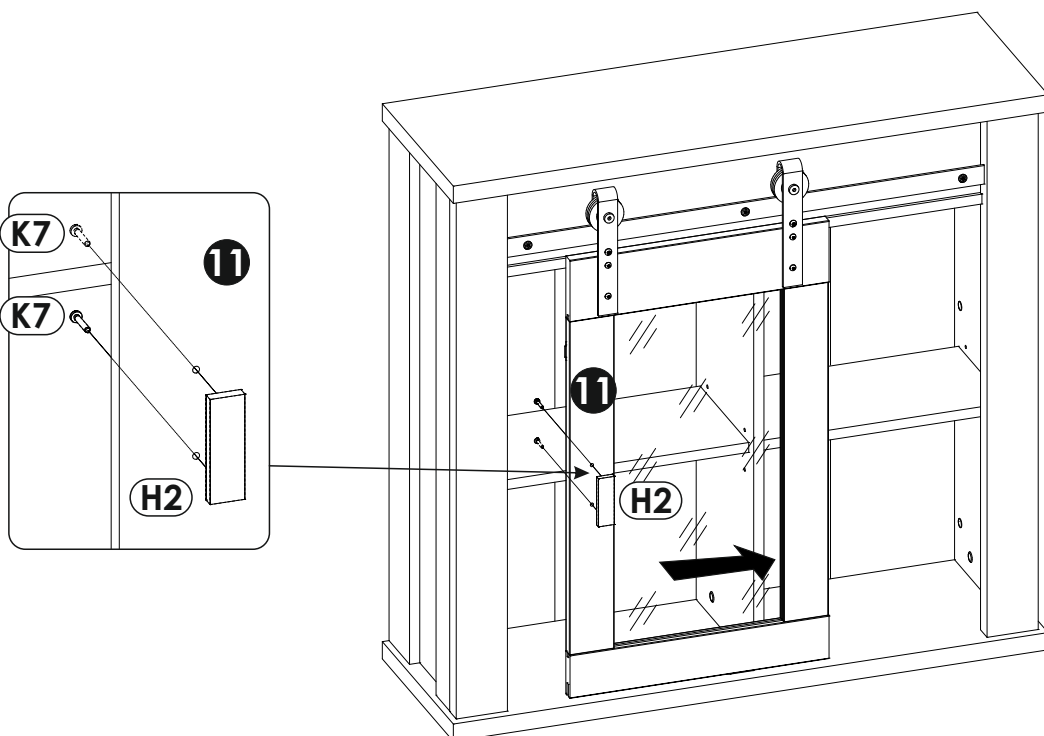
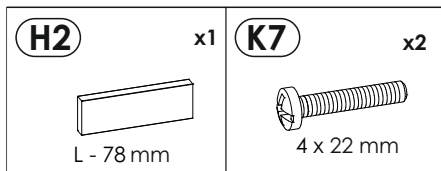

43 ▶

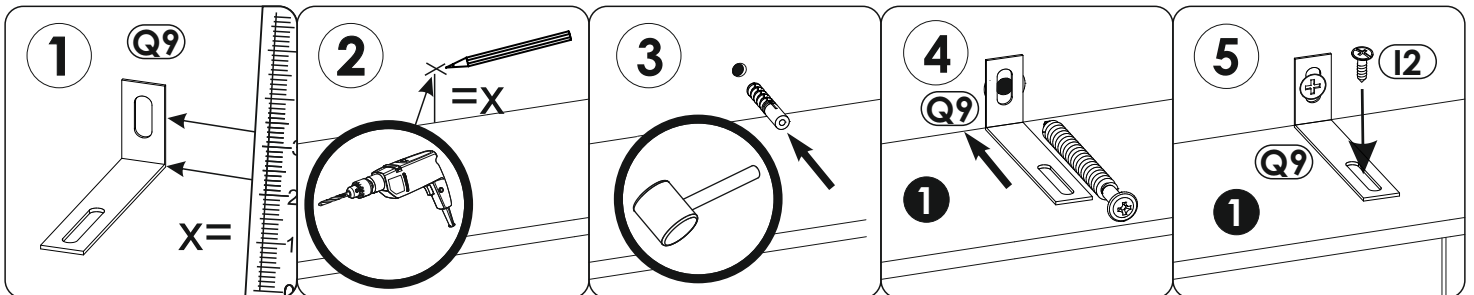
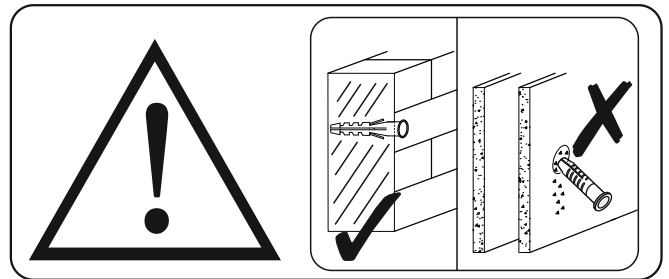
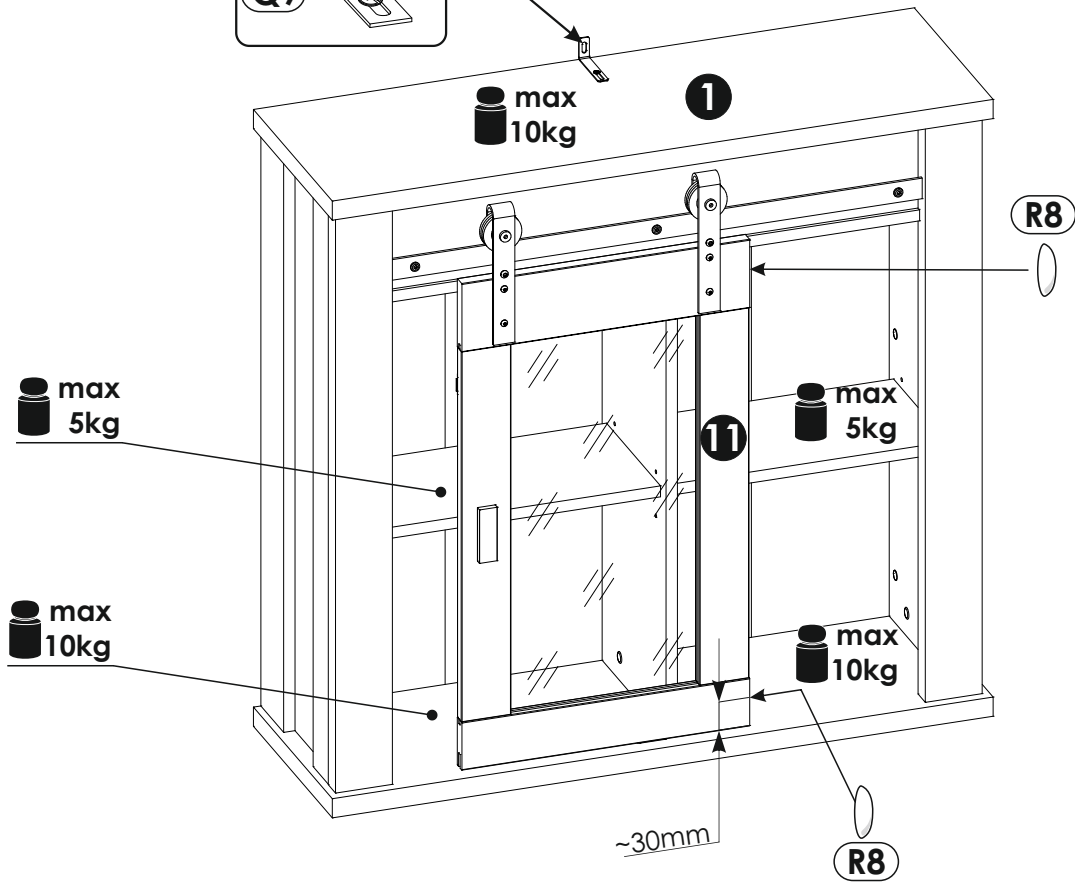
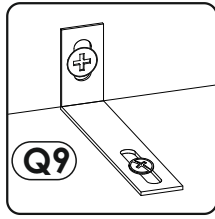
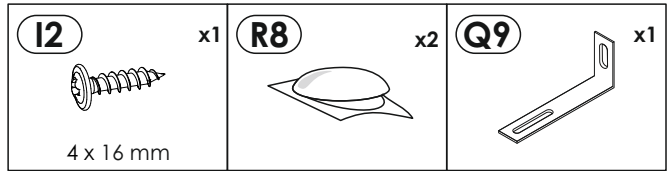

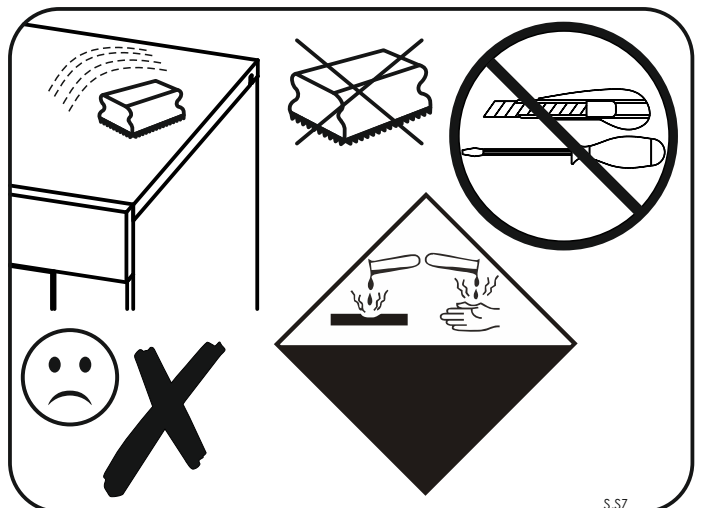
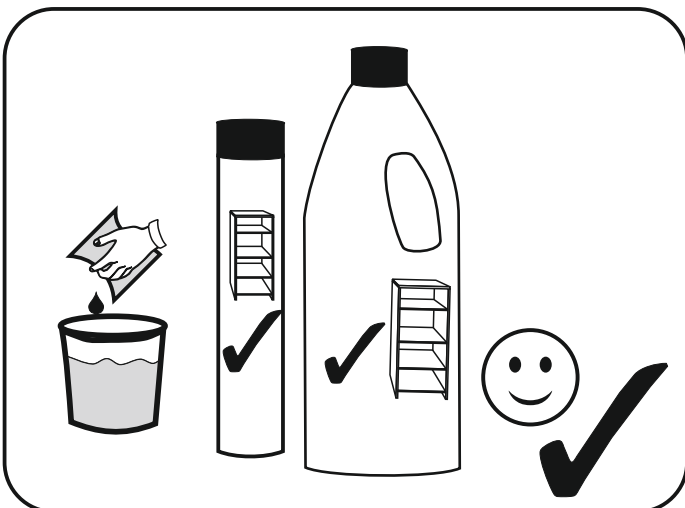
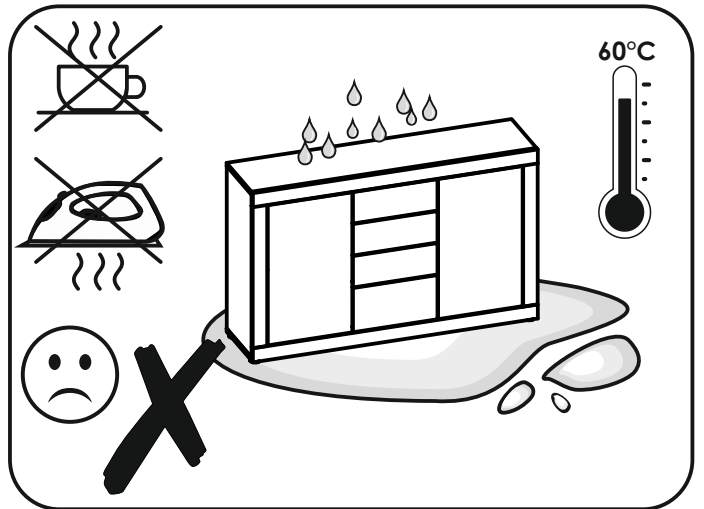
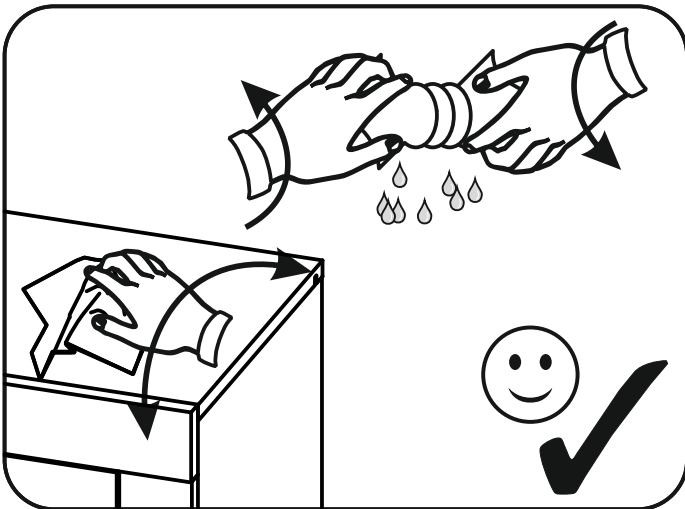
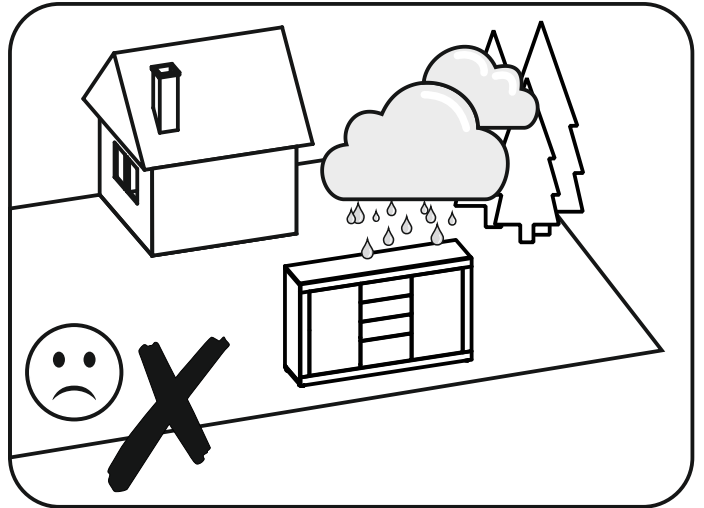
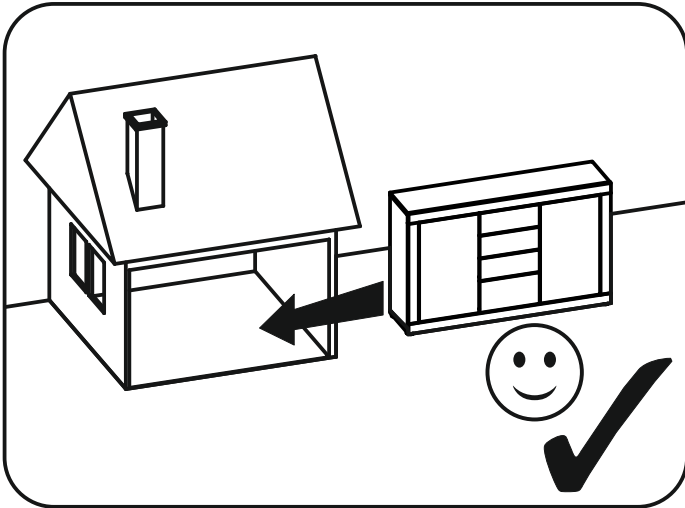

1YYASCH5/1PPASCH5

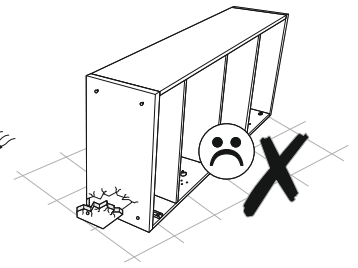
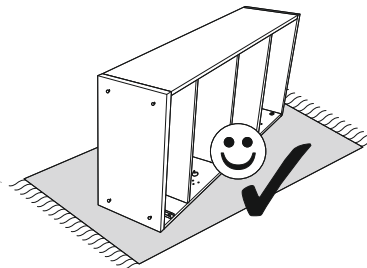
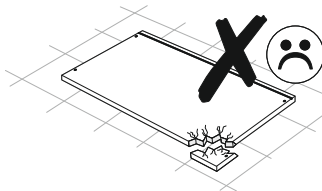
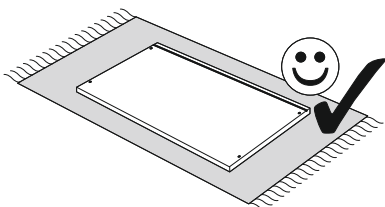
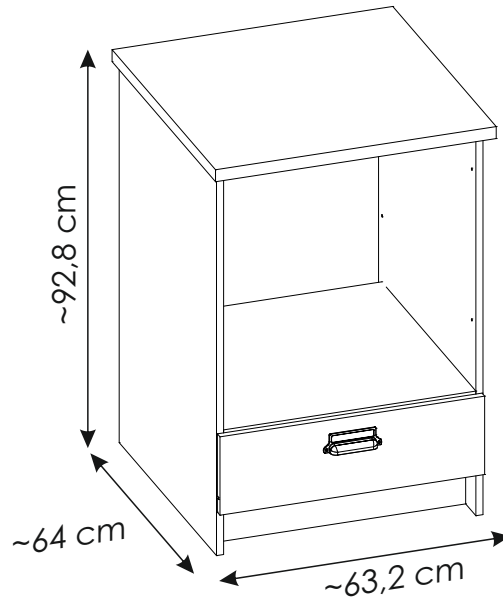
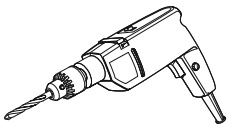
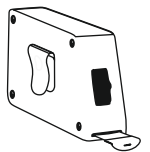
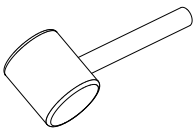
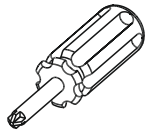
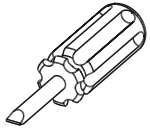
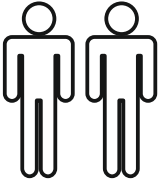

OPTIONS

OPTION A

A

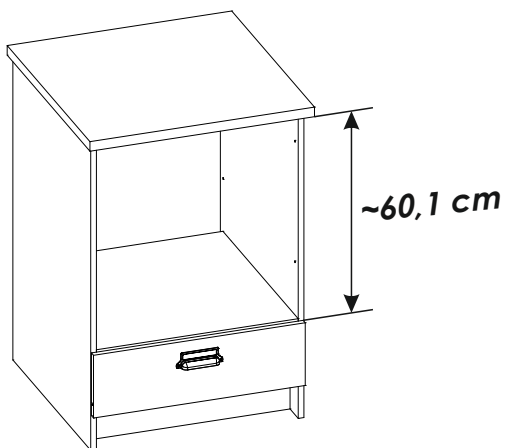

B

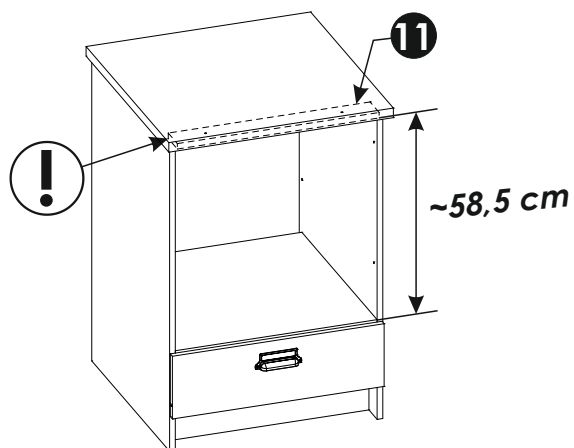

9-15

OPTION B

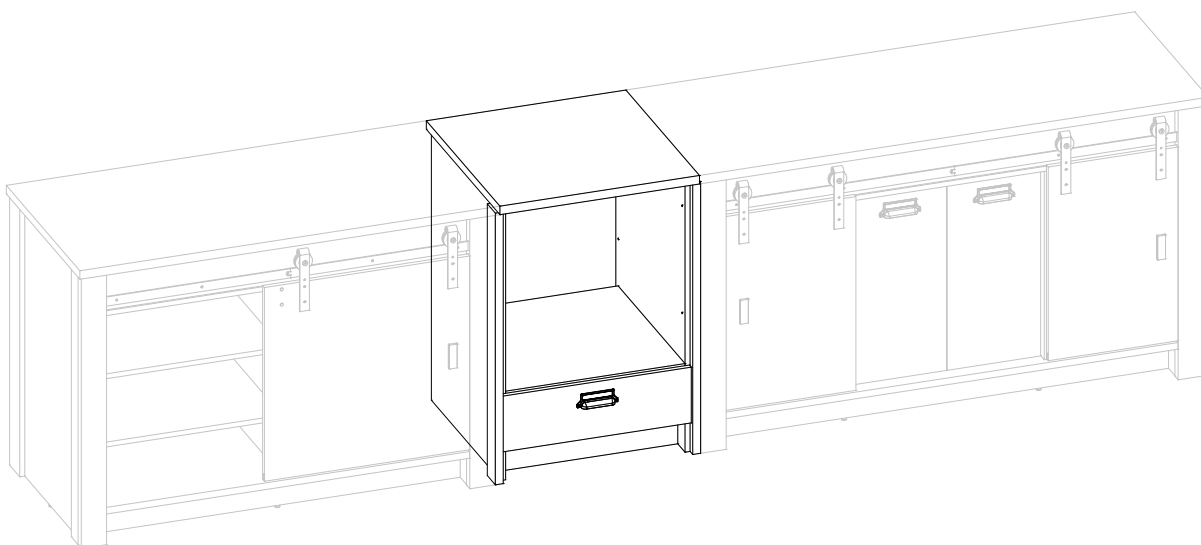

16-17

OPTIONS

OPTION C

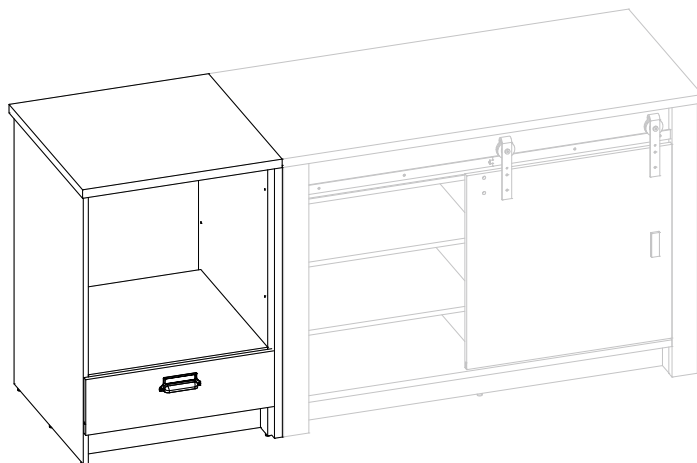

18-19

OPTIONS

OPTION D

A

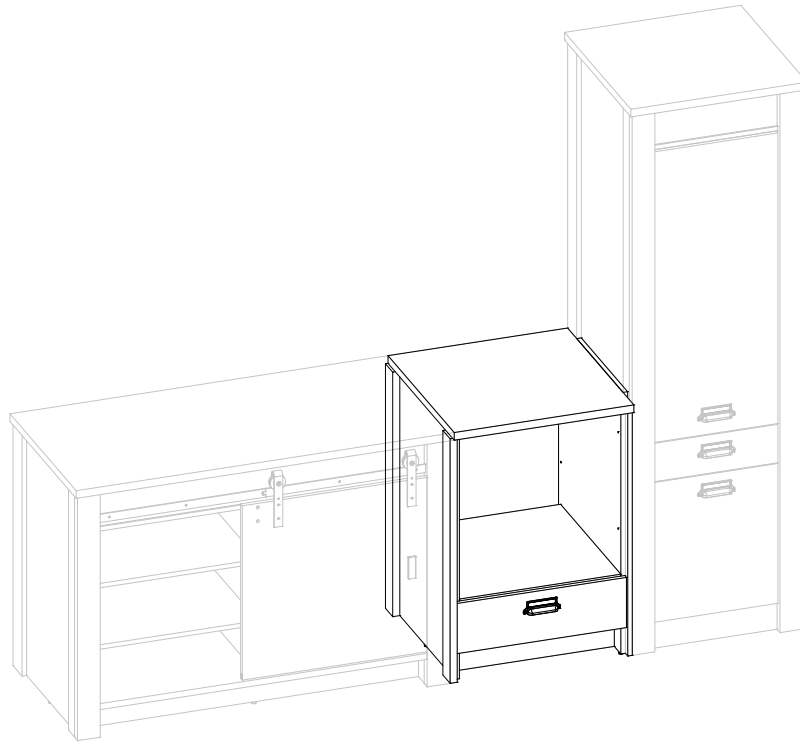

20-22

B

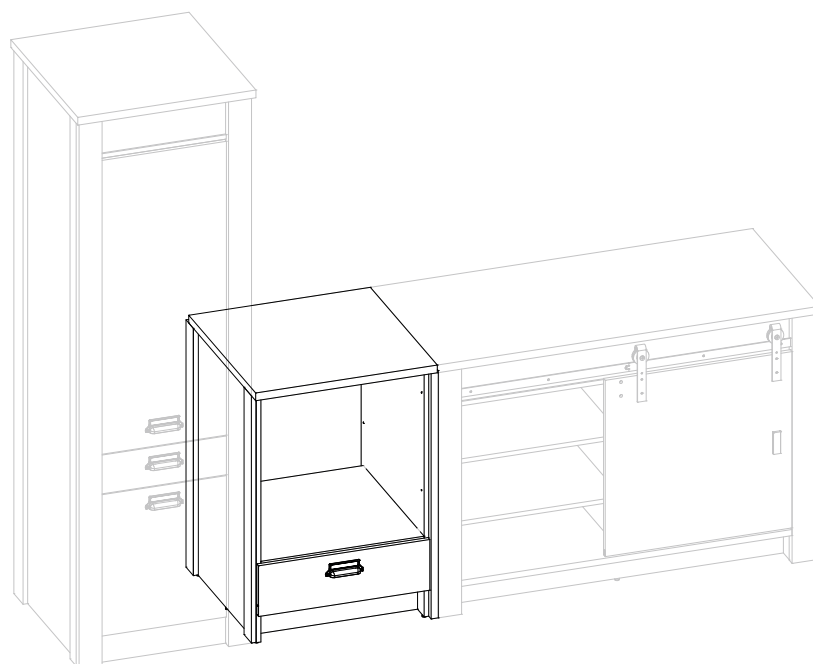

23-25

ملاحظة!

يجب تثبيت الأثاث بإحكام إلى الحائط أو الجدار لتجنب خطر إنقلابه. لا تحتوي العلبة على مسامير التثبيت، إذ إنه ينبغي إستعمال المسامير المخصصة لنوعية الحائط أو الجدار. اختر المسامير التي تناسب جدارك.

E.

¡ATENCIÓN! El mueble debe ser fijado permanentemente a la pared para evitar el riesgo relacionado con el vuelco del mueble. En el paquete no hay tornillos de fijación, ya que se debe elegir el tipo de fijación adecuado para el tipo de pared. Elija el apropiado para su tipo de pared.

CN.

注意！本家具需要固定在墙上以免倒塌。箱子里没有安装螺钉。因为安装方式需要根据墙的类型调整。请按照您的墙类型选择合适的安装方式。

SLO.

POZOR! Pohišvo trajno pritrдите na steno, da preprečite tveganje, da se prevrne. V paketu ni pritrđilnih vijakov, saj je treba način pritrđitve ustrezno izbrati glede na vrsto stene. Izberite način, ki je ustrezen za vašo steno.

HU.

FIGYELEM! Rögzítse a bútorokat a falhoz, hogy elkerülje a bútor felborulásának kockázatát. A készletben nem találhatóak rögzítőcsavarok, mivel a rögzítés típusa a fal típusától függ. Válassza ki a fal típusának megfelelő kötőelemeket.

NL.

OPMERKING! De meubelen moeten permanent aan de muur worden bevestigd om te voorkomen dat de meubelen kantelen. Er zitten geen bevestigingsschroeven in het pakket, omdat het type bevestiging moet worden gekozen op basis van het type muur. Kies de juiste voor uw type muur.

EN.

WARNING! To prevent this furniture from tripping over, fix it to the wall permanently. Fixing devices are not included since different wall materials require different types of fixing devices. Please make sure you chose the correct ones for your type of wall.

SK.

POZOR! Nábytok musí byť trvalo pripevnený k stene tak, aby sa zamedzilo riziku prevrátenia. Balík neobsahuje upevňovacie skrutky, pretože typ upevnenia je treba vybrať podľa typu steny. Vyberte typ vhodný pre Vašu stenu.

CZ.

POZOR! Nábytek je nutné pevně připevnit ke zdi, abychom se vyhnuli riziku spojenému s jeho převrnutím. Součástí balení nejsou připevňovací šrouby, protože způsoby připevnění je nutné zvolit podle druhu stěny. Vyberte správný pro Váš typ stěny.

RU.

ПРИМЕЧАНИЕ! Эту мебель необходимо всегда прикреплять к стене, чтобы избежать рисков, связанных с переворотом мебели. В пакете нет крепежных винтов, потому что тип крепления должен быть выбран в соответствии с типом стены. Выберите, пожалуйста, правильные винты к вашей стене.

RO.

ATENȚIE! Mobila trebuie ancorată permanent în perete pentru a evita riscul de răsturnare a mobilei. În pachet nu sunt incluse șuruburile de fixare, deoarece tipul de ancoraj trebuie ales în funcție de tipul de perete. Alegeți șuruburile potrivite pentru tipul Dvs. de perete.

TR.

DİKKAT! Devrilmeye riskini önlemek için mobilya duvara sabitlenmelidir. Sabitleme civataları pakete dahil değildir, çünkü sabitleme tertibatının tipi, duvara tipine uygun olarak seçilmelidir. Onu duvarınızın tipine göre seçiniz.

PL.

UWAGA! Mebel należy trwale zamocować do ściany, aby uniknąć ryzyka związanego z przewróceniem się mebla. W paczce nie ma śrub mocujących, ponieważ rodzaj mocowania należy odpowiednio dobrać do rodzaju ściany. Dobierz właściwe do Twojego rodzaju ściany.

D.

ACHTUNG! Um alle mit dem Umkippen des Möbels verbundenen Risiken auszuschließen, muss das Möbel fest an der Wand verankert werden. Beschläge für die Wandbefestigung sind nicht beige packt, da diese von der jeweiligen Wandbeschaffenheit abhängig sind. Bitte solche Befestigungsschläge wählen, die für die heimischen Wände geeignet sind.

FR.

ATTENTION! Ce meuble doit être fixé en permanence au mur pour éviter les risques de chute. Les vis de fixation ne sont pas livrées car le type de fixation doit être choisi en fonction du type de mur. Sélectionnez les fixations adaptées au mur.

I.

ATTENZIONE! Il mobile deve essere permanentemente fissato alla parete per evitare i rischi derivanti da un ribaltamento del mobile. La confezione non include le viti di fissaggio, in quanto il tipo di fissaggio deve essere scelto in base al tipo di parete. Utilizzare viti appropriate in base al materiale della parete.





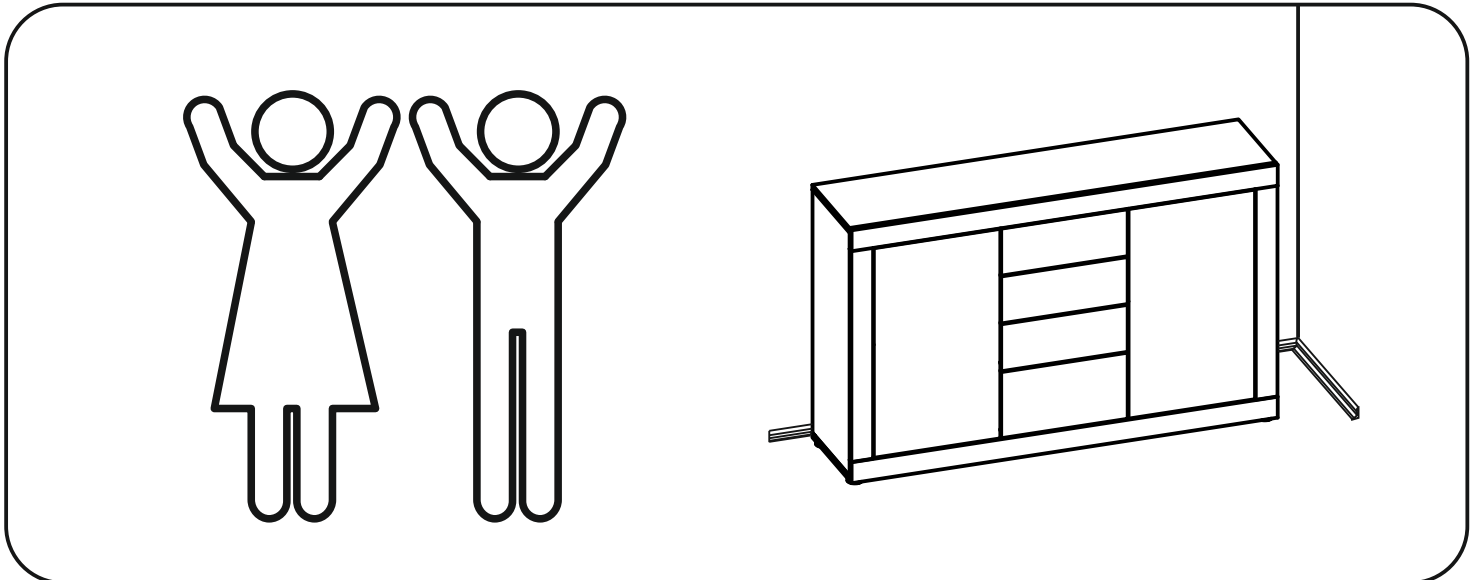
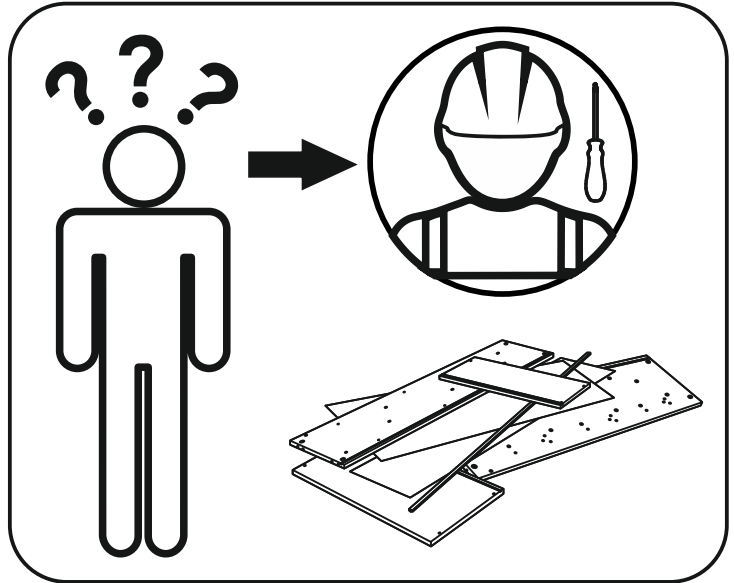
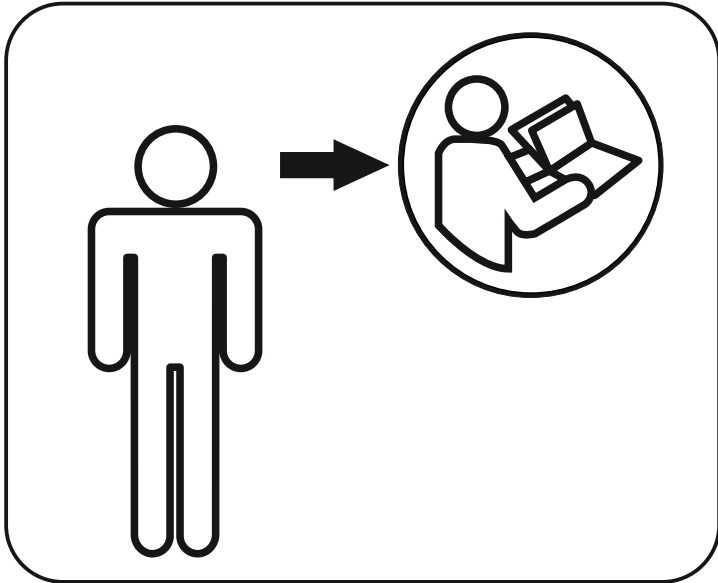
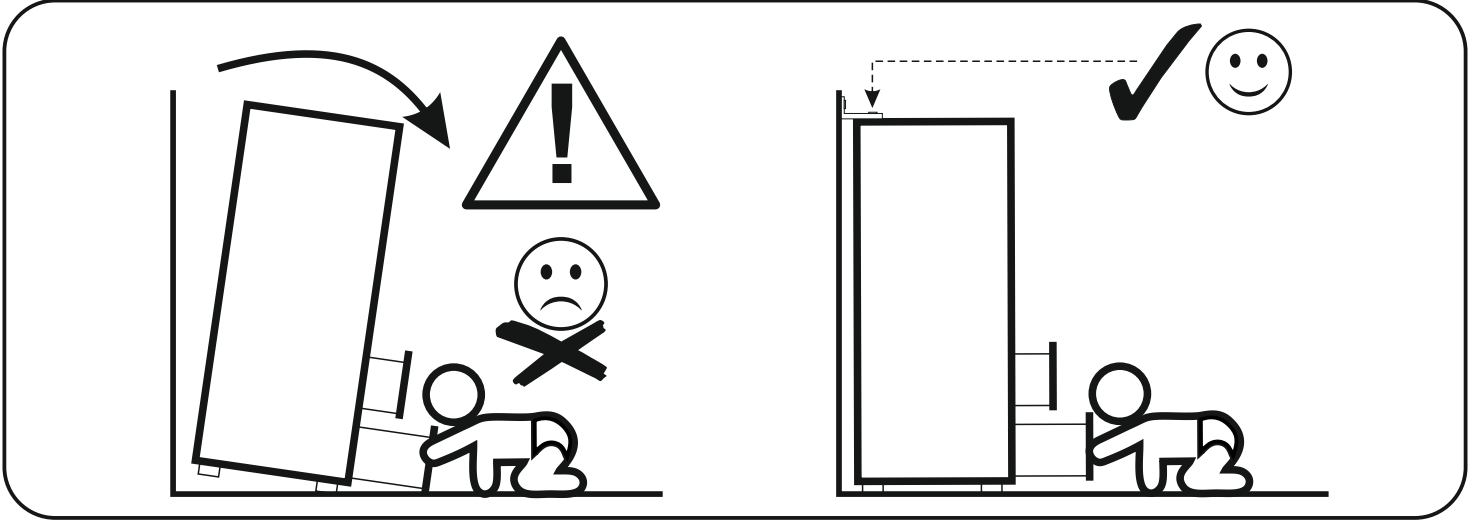
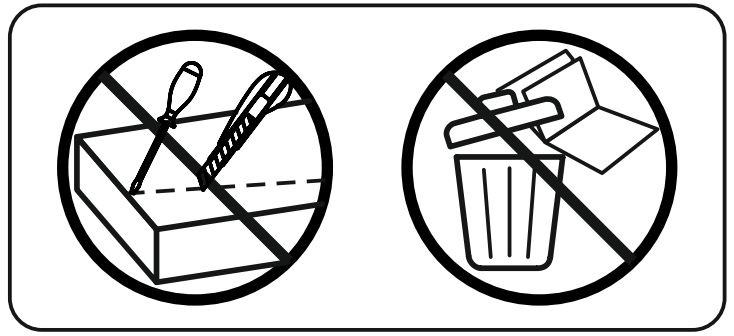
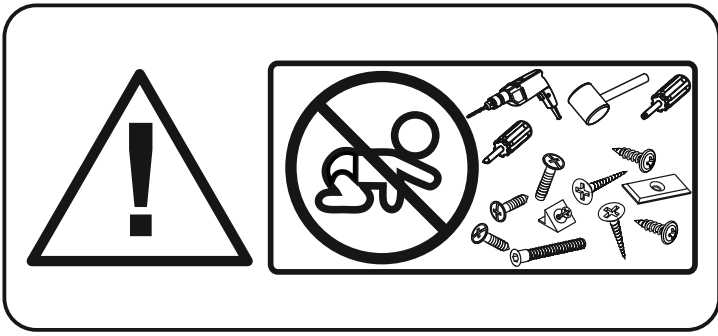



HR.

NAPOMENA! Namještaj mora biti trajno pričvršćen za zid, kako bi se izbjegao rizik od njegovog prevrtanja. U paketu nema vijaka za pričvršćivanje, jer se vrsta montaže mora prilagoditi vrsti zida. Odaberite pravu vrstu prema Vašoj vrsti zida.

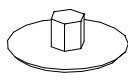

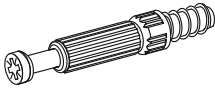
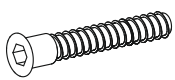
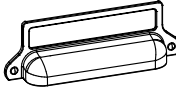
1YYASCH5/1PPASCH5

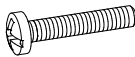
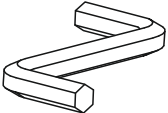
MM

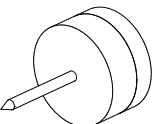
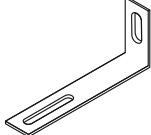
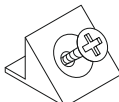
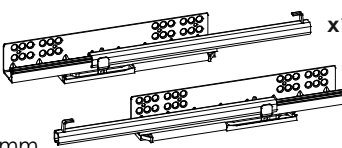
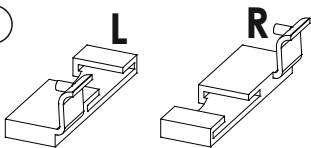
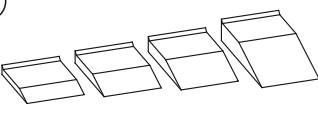
<p>A1 8 x 35 mm x20</p> 	<p>C2 5 x 13 mm x4</p> 	<p>E0 Ø16 x2</p> 
<p>E1 15 x 12 mm x12</p> 	<p>F1 6 x 34 mm x12</p> 	<p>G1 7 x 50 mm x2</p> 
<p>H1 L - 131 mm x1</p> 	<p>I2 4 x 16 mm x1</p> 	<p>K7 4 x 22 mm x2</p> 
<p>M x1</p> 	<p>N1 3 x 16 mm x5</p> 	<p>N14 4 x 30 mm x16</p> 
<p>O3 x6</p> 	<p>Q9 x1</p> 	<p>R4 x1</p> 
<p>T12 x1 L - 500 mm</p> 	<p>TZ L R x1</p> 	<p>Z x1</p> 

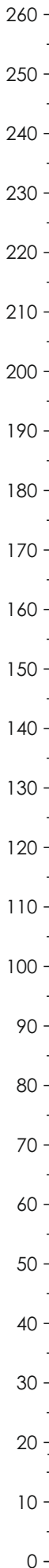

1YYASCH5/1PPASCH5

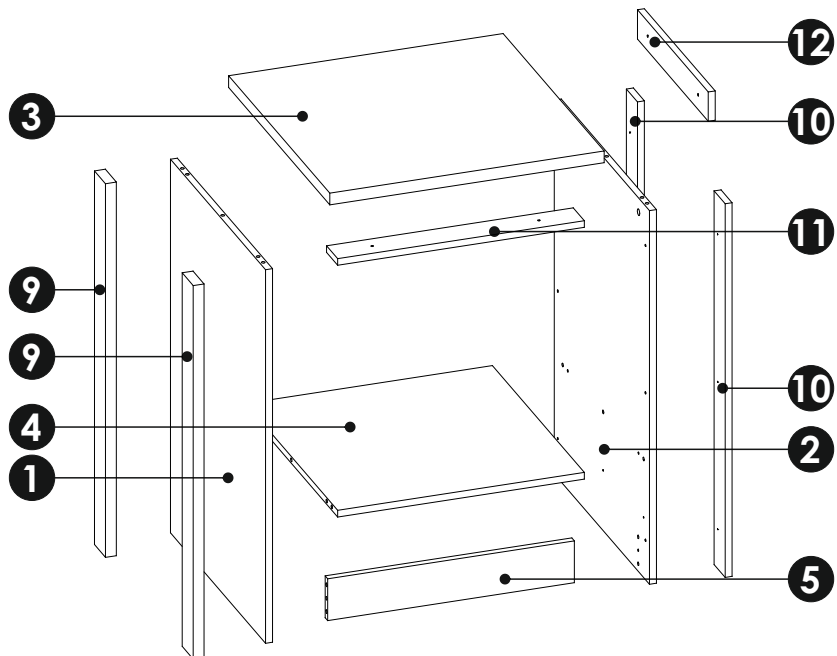
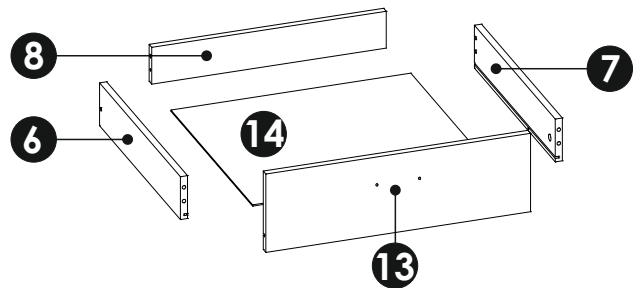
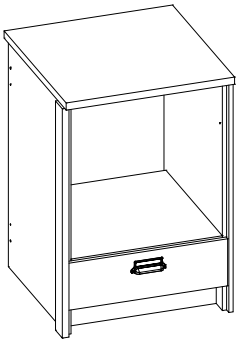

1	892	602	16 x1	1/1	8	528	86	16 x1	1/1
2	892	602	16 x1	1/1	9	892	70	25 x2	1/1
3	632	640	28 x1	1/1	10	892	70	16 x2	1/1
4	568	582	16 x1	1/1	11	568	70	16 x1	1/1
5	568	100	16 x1	1/1	12	448	70	16 x1	1/1
6	500	100	16 x1	1/1	13	596	183	16 x1	1/1
7	500	100	16 x1	1/1	14	540	505	3 x1	1/1

OPTION A

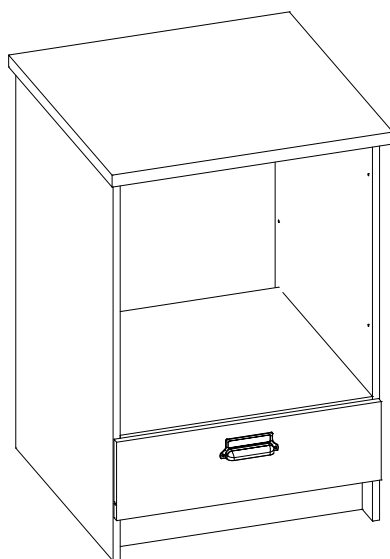

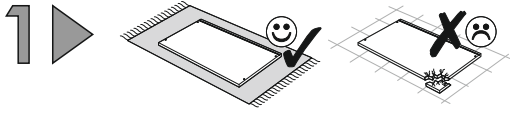
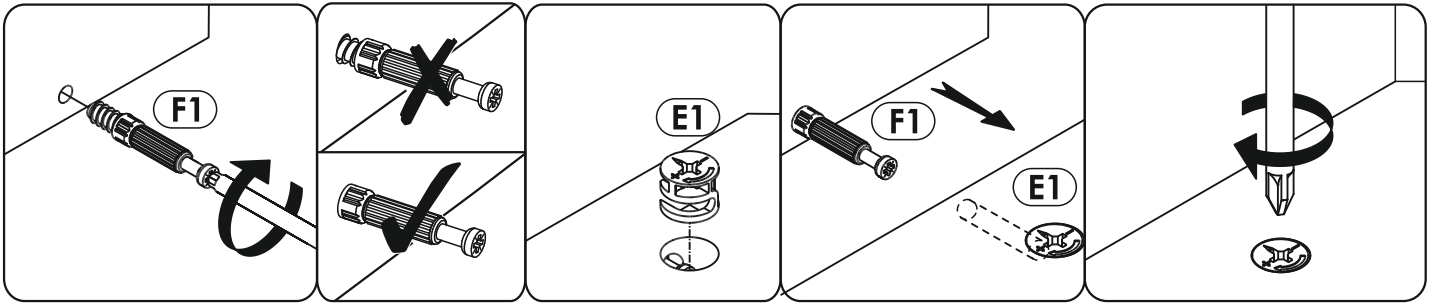

A1 x3 8 x 35 mm	C2 x2 5 x 13 mm	E1 x2 15 x 12 mm	F1 x3 6 x 34 mm
O3 x3	T12 x1 L - 500 mm		

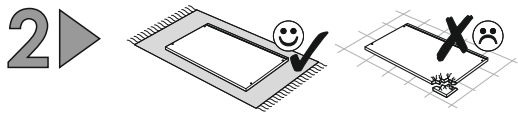
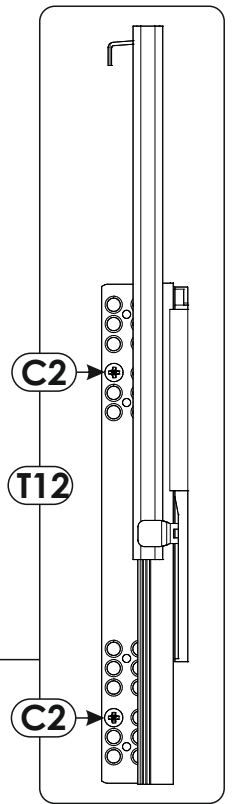
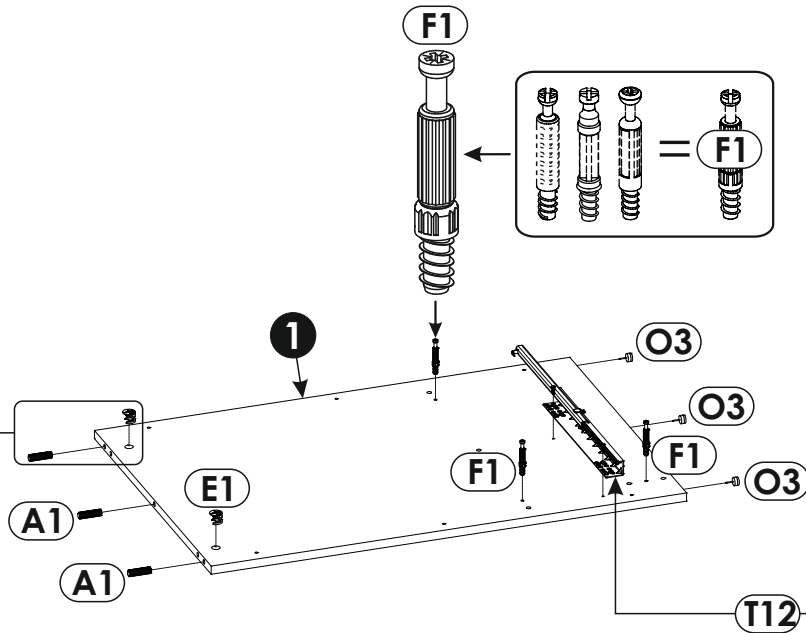
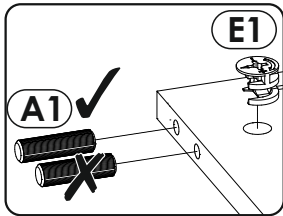

A1 x6 8 x 35 mm	E1 x4 15 x 12 mm
------------------------------	-------------------------------

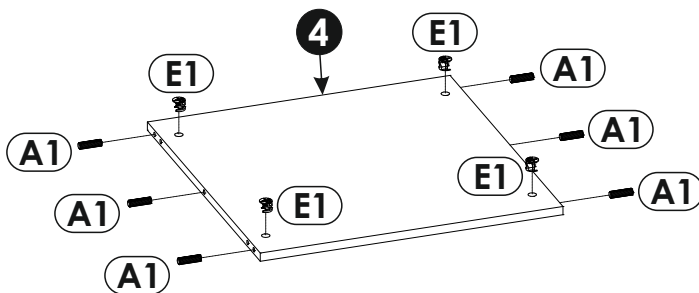

3 ▶

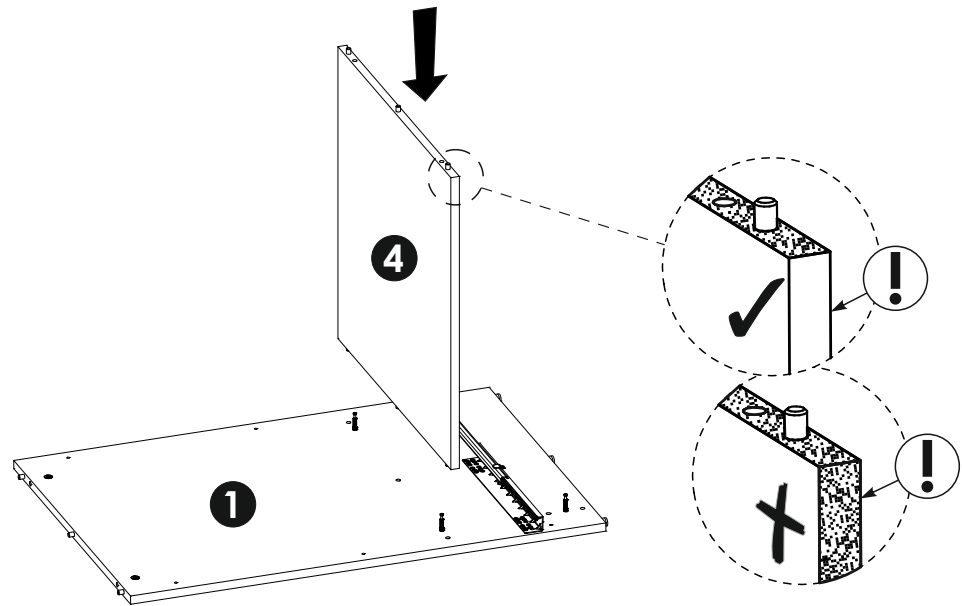
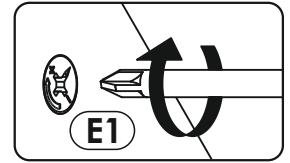
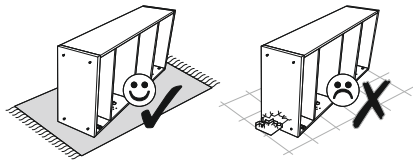

4 ▶

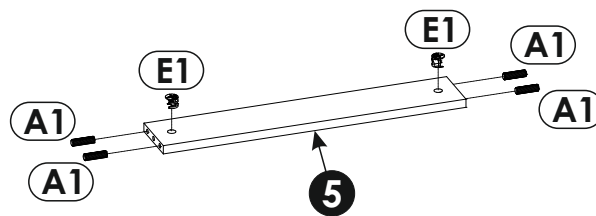
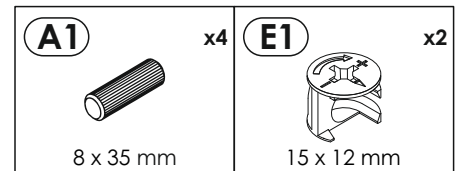
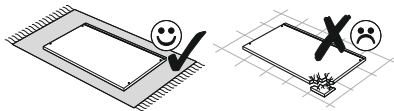

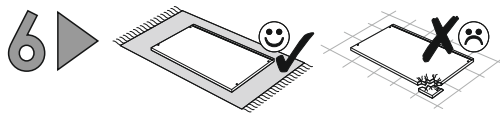
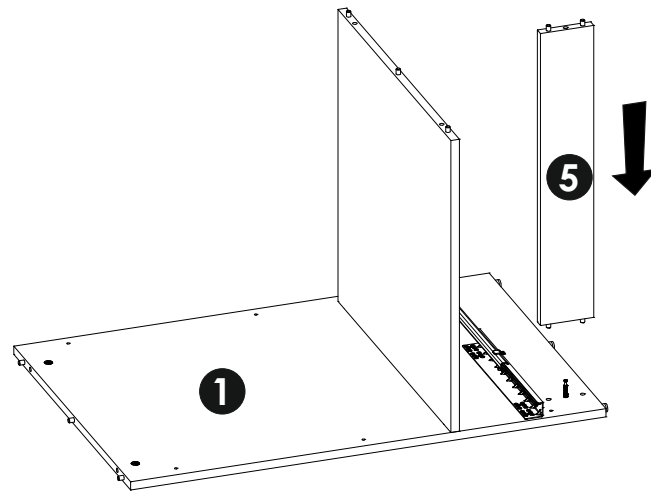
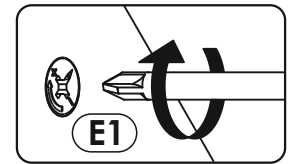
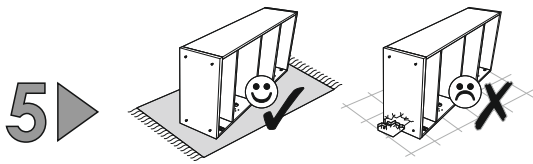

A1 x3 8 x 35 mm	C2 x2 5 x 13 mm	E1 x2 15 x 12 mm	F1 x3 6 x 34 mm
O3 x3 L - 500 mm	T12 x1 		

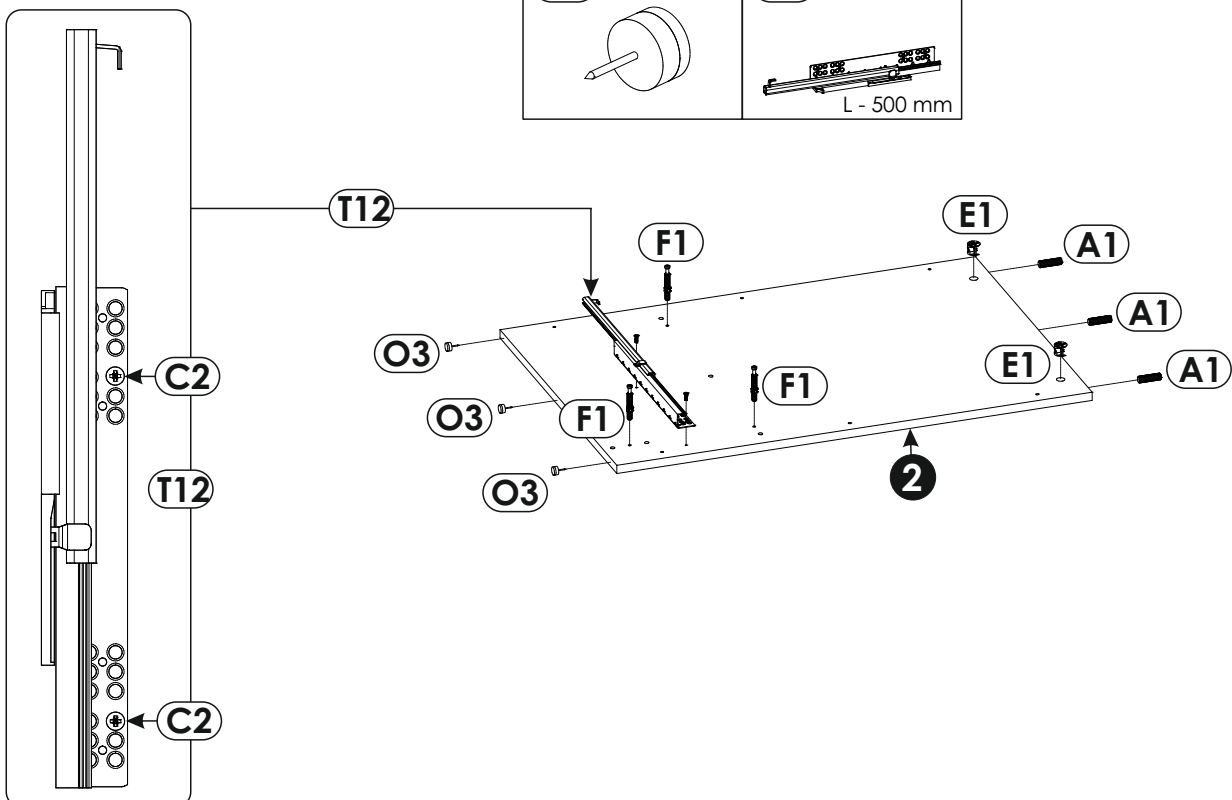

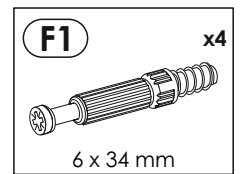
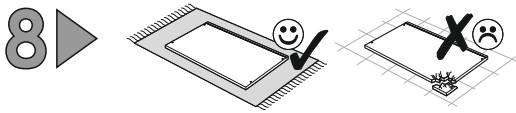
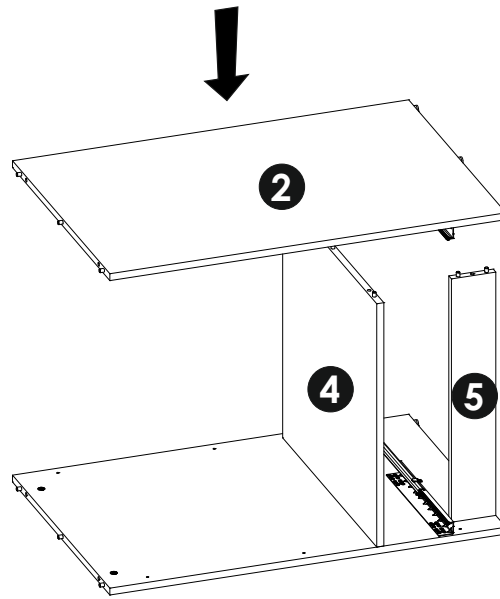
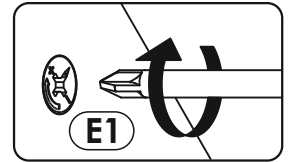
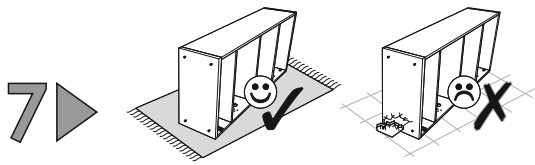

A

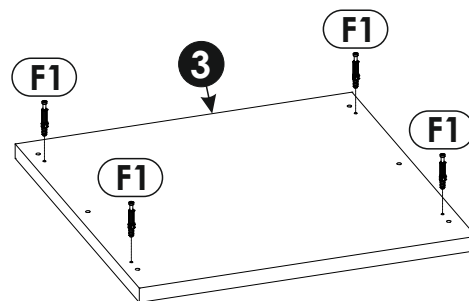

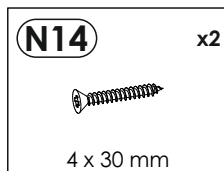
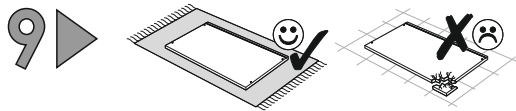

B

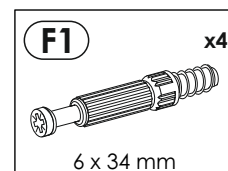
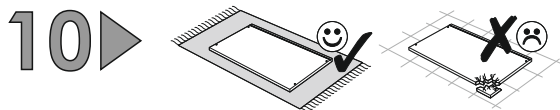
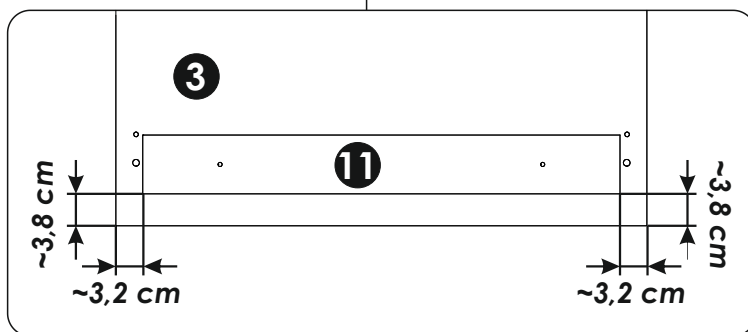
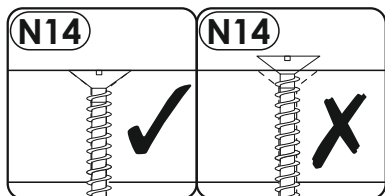
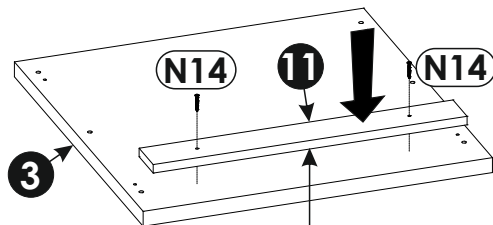

B

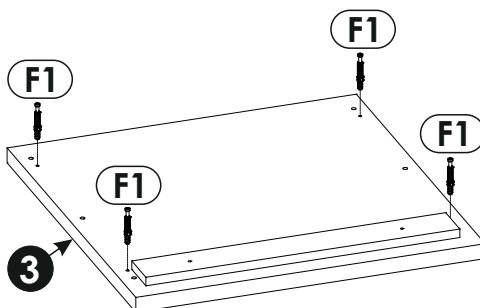

11 ▶

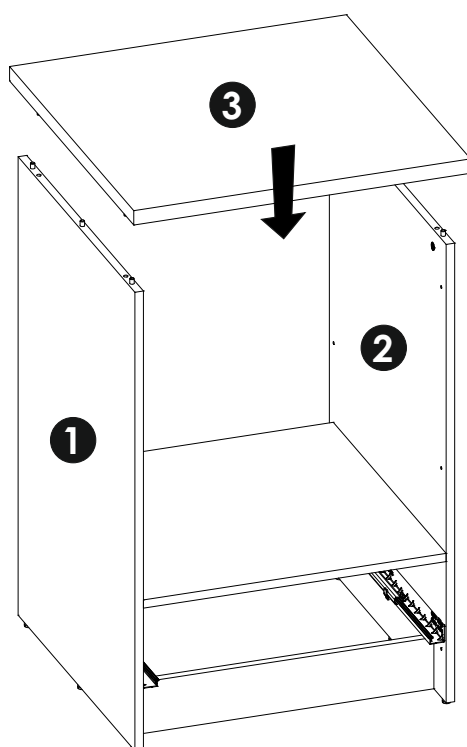
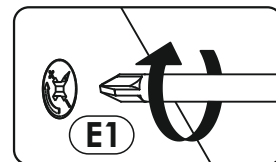
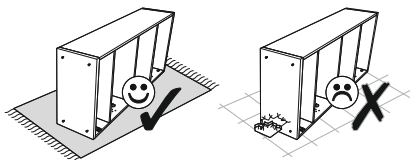

OPTION B

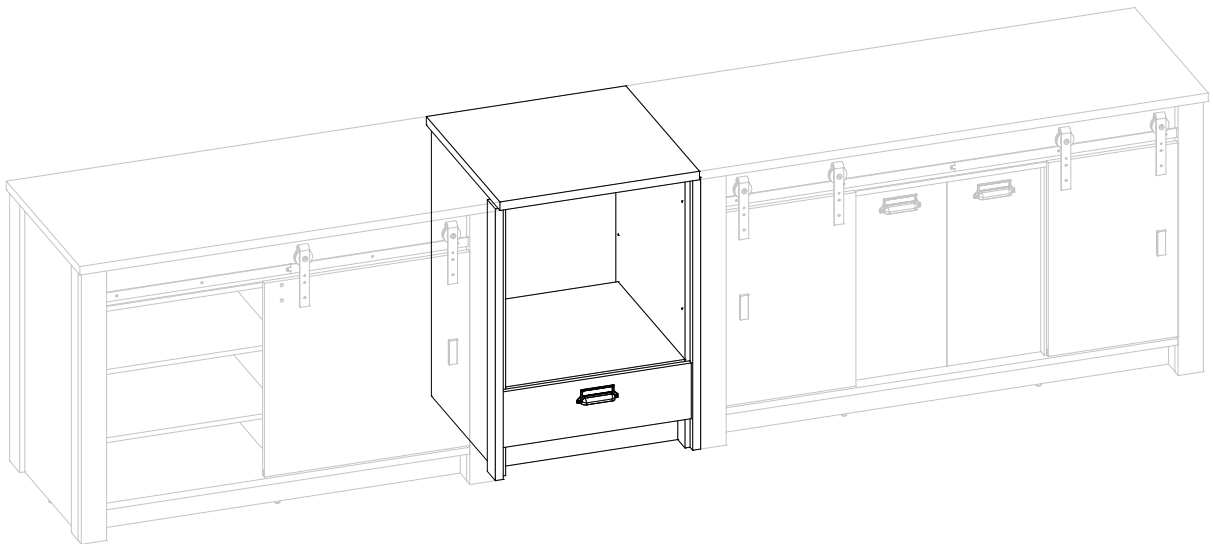

12 ▶

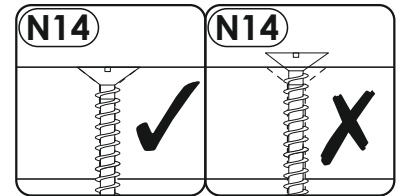
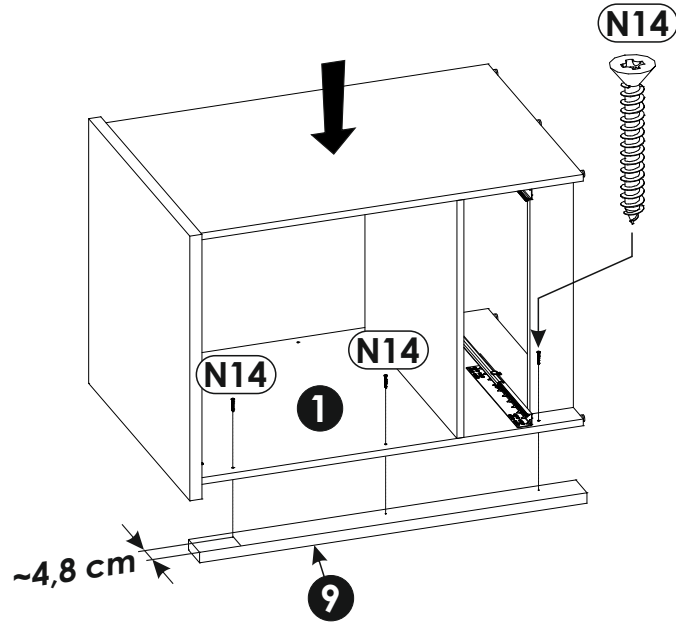
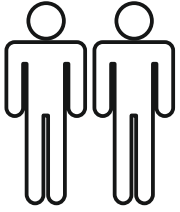
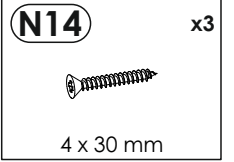
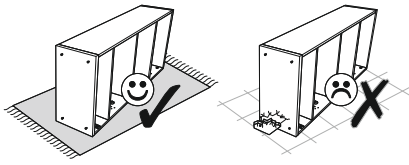

13 ▶

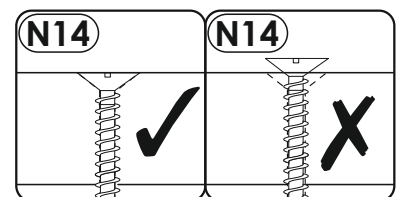
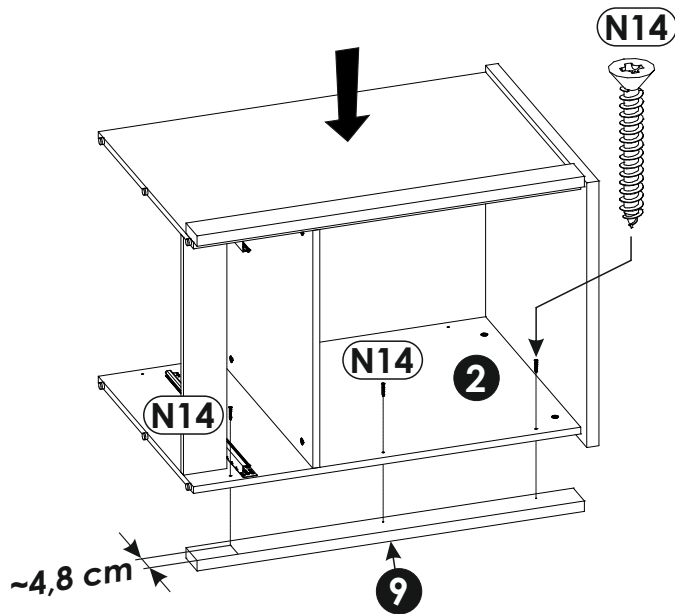
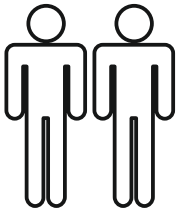
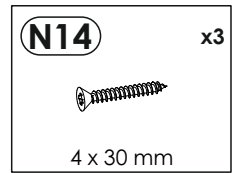
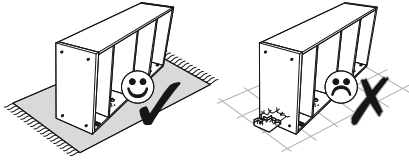

OPTION C

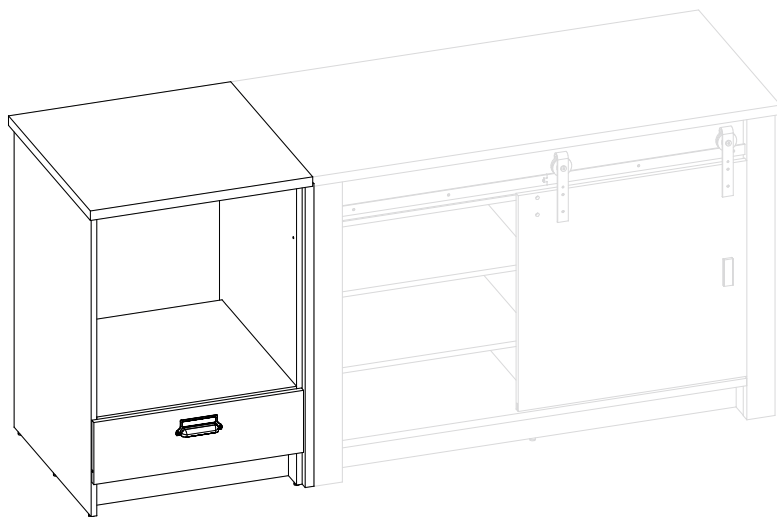

14 ▶

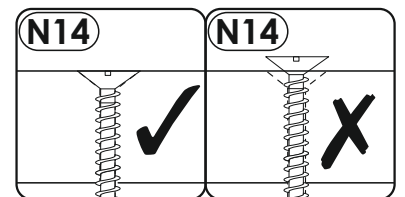
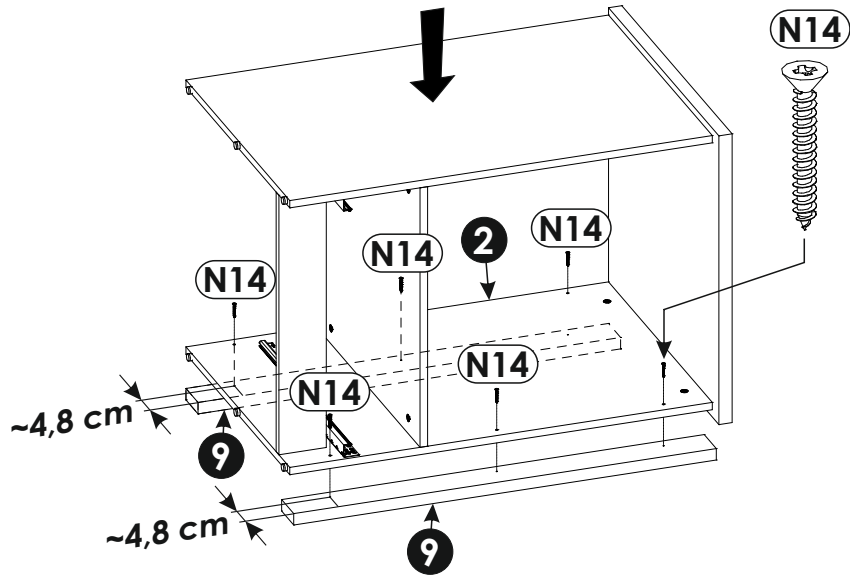
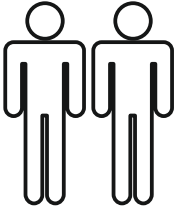
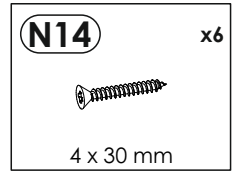
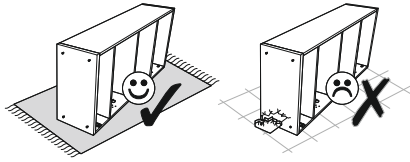

OPTION D

A

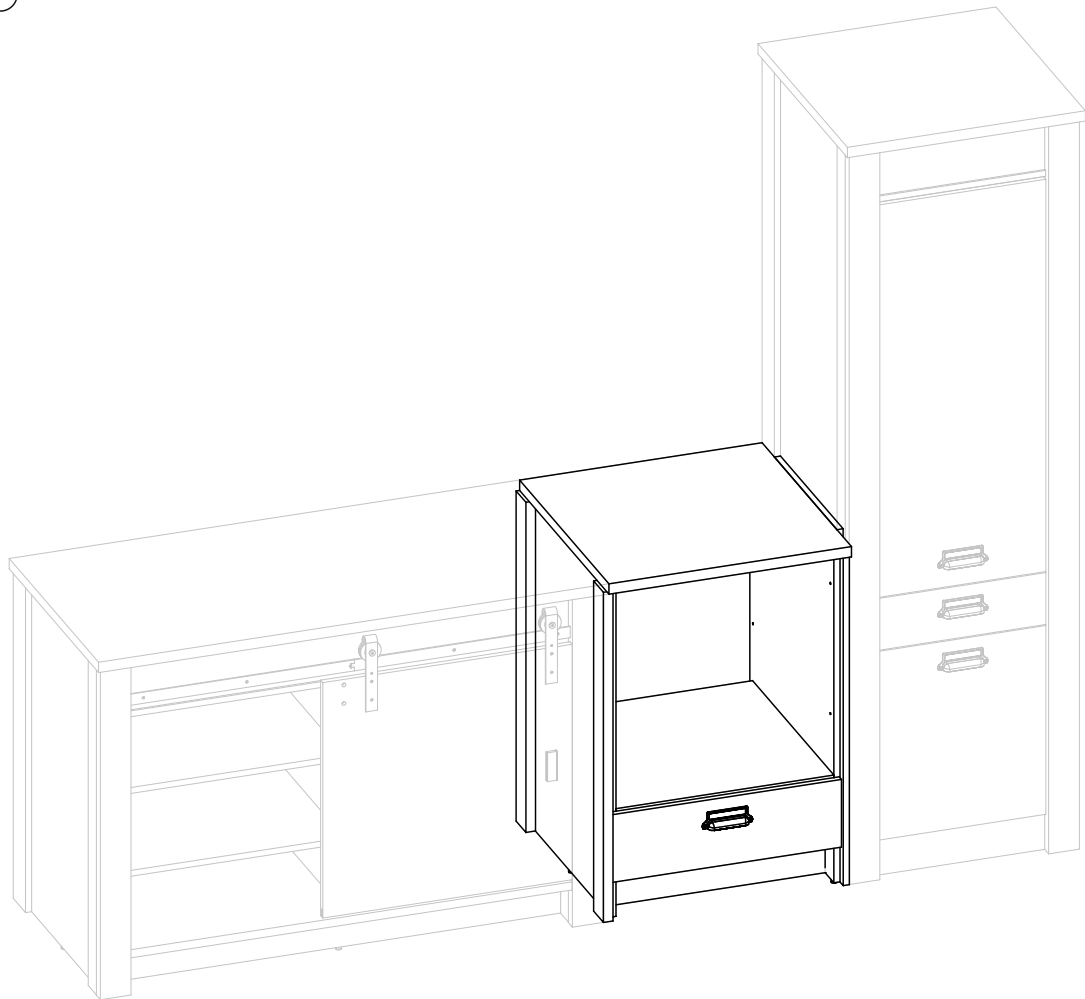

15 ▶

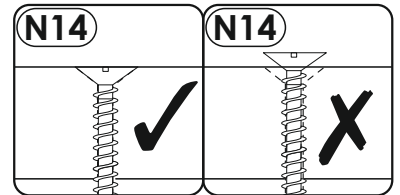
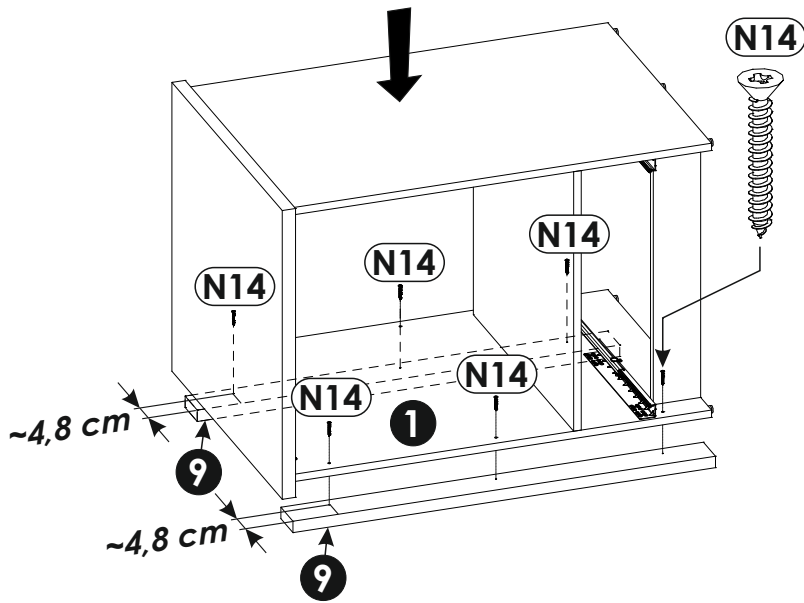
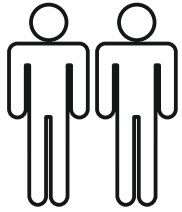
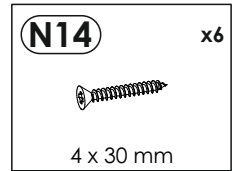
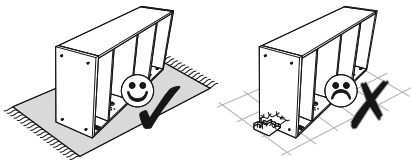

16 ▶

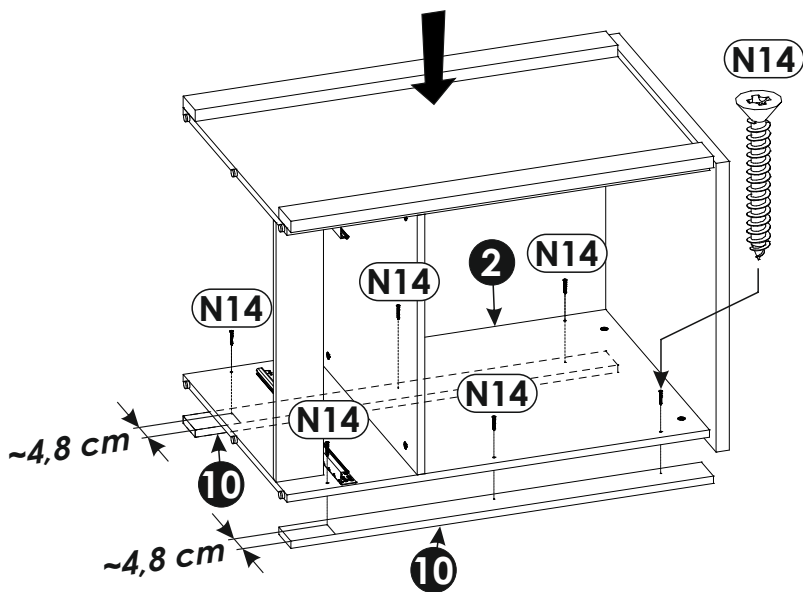
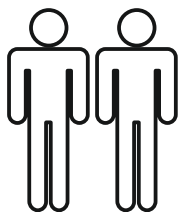
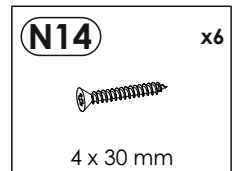
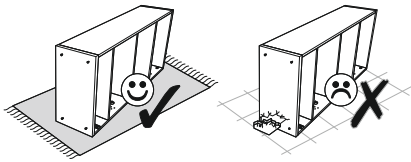

17 ▶

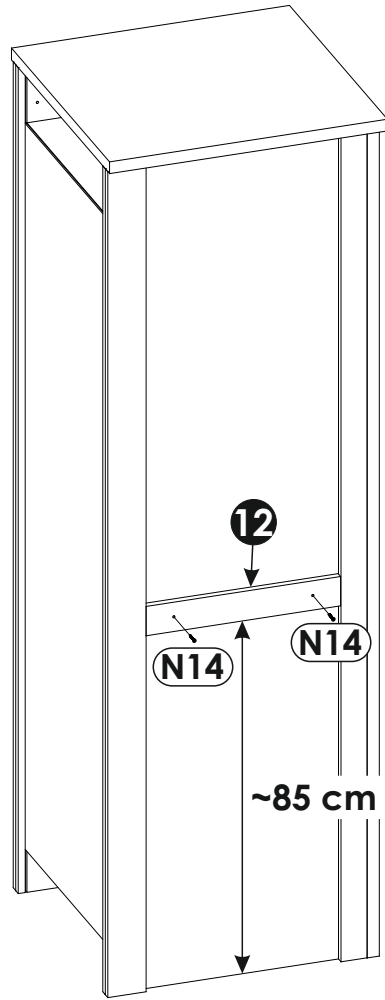
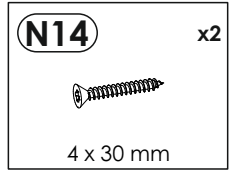
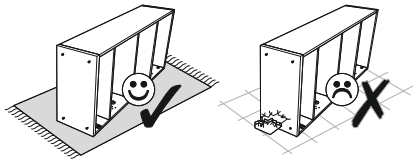

OPTION D

B



18 ▶

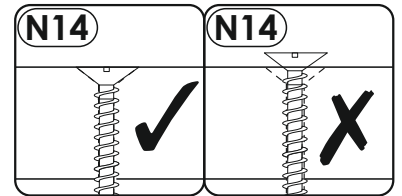
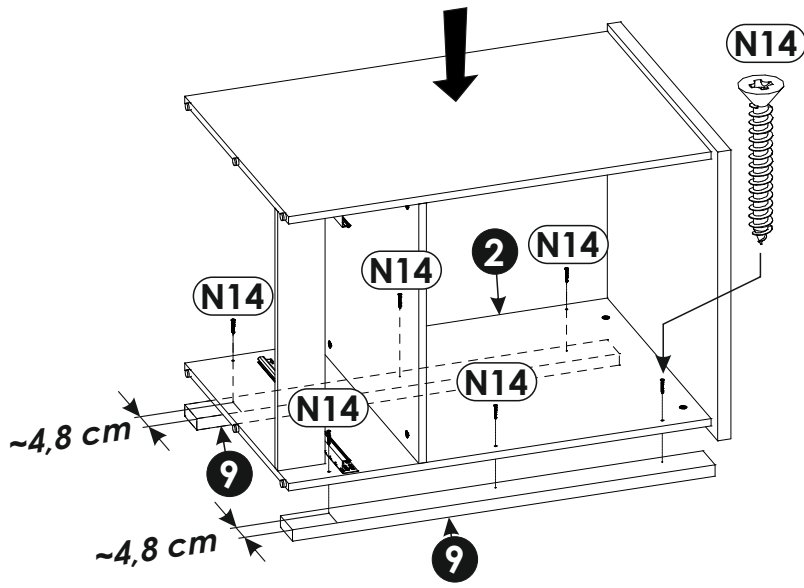
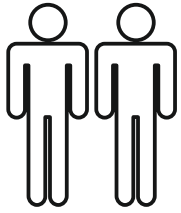
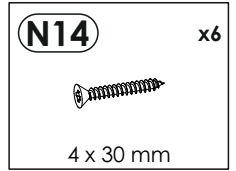
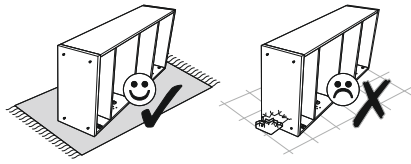

19 ▶

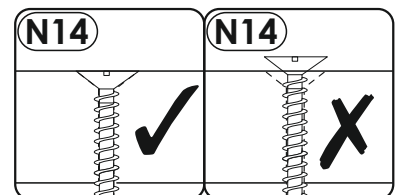
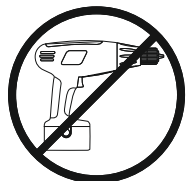
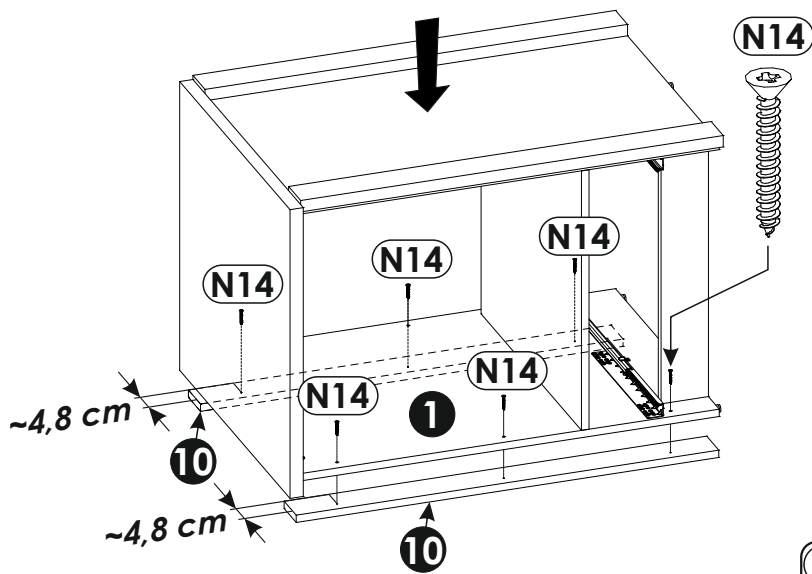
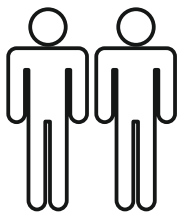
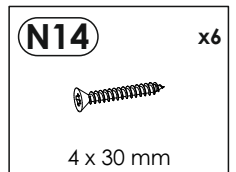
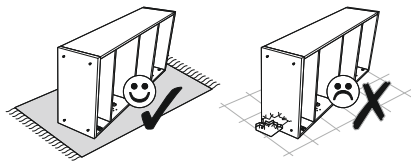

20 ▶

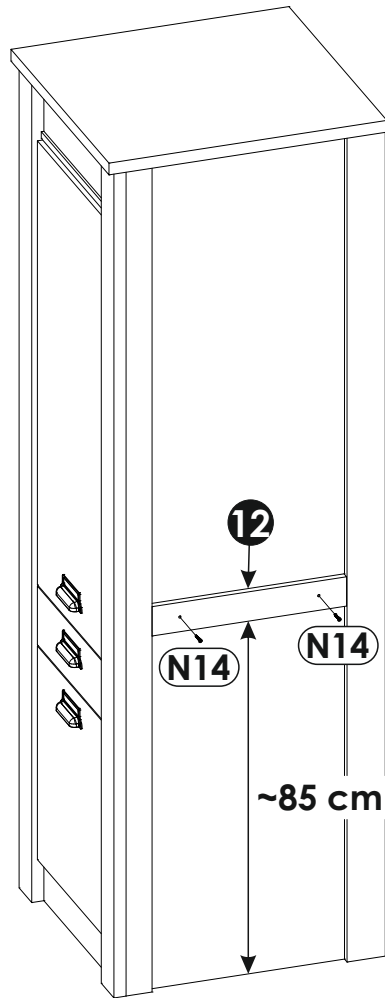
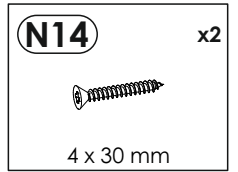
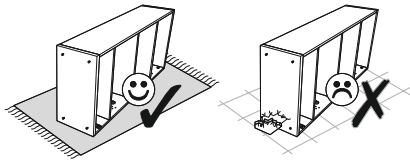

21 ▶

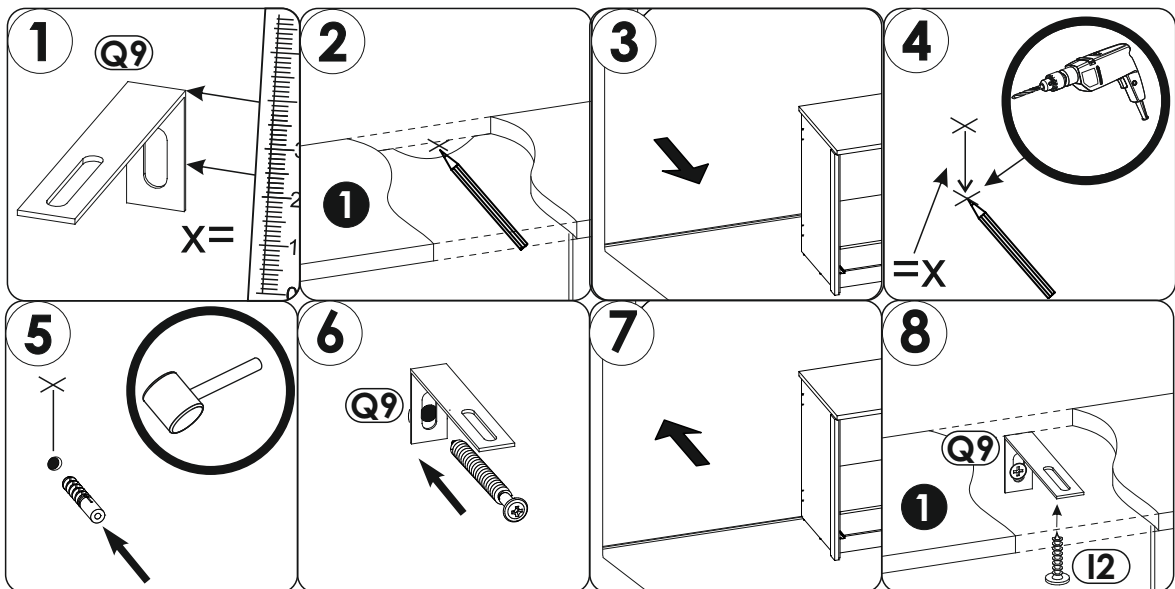
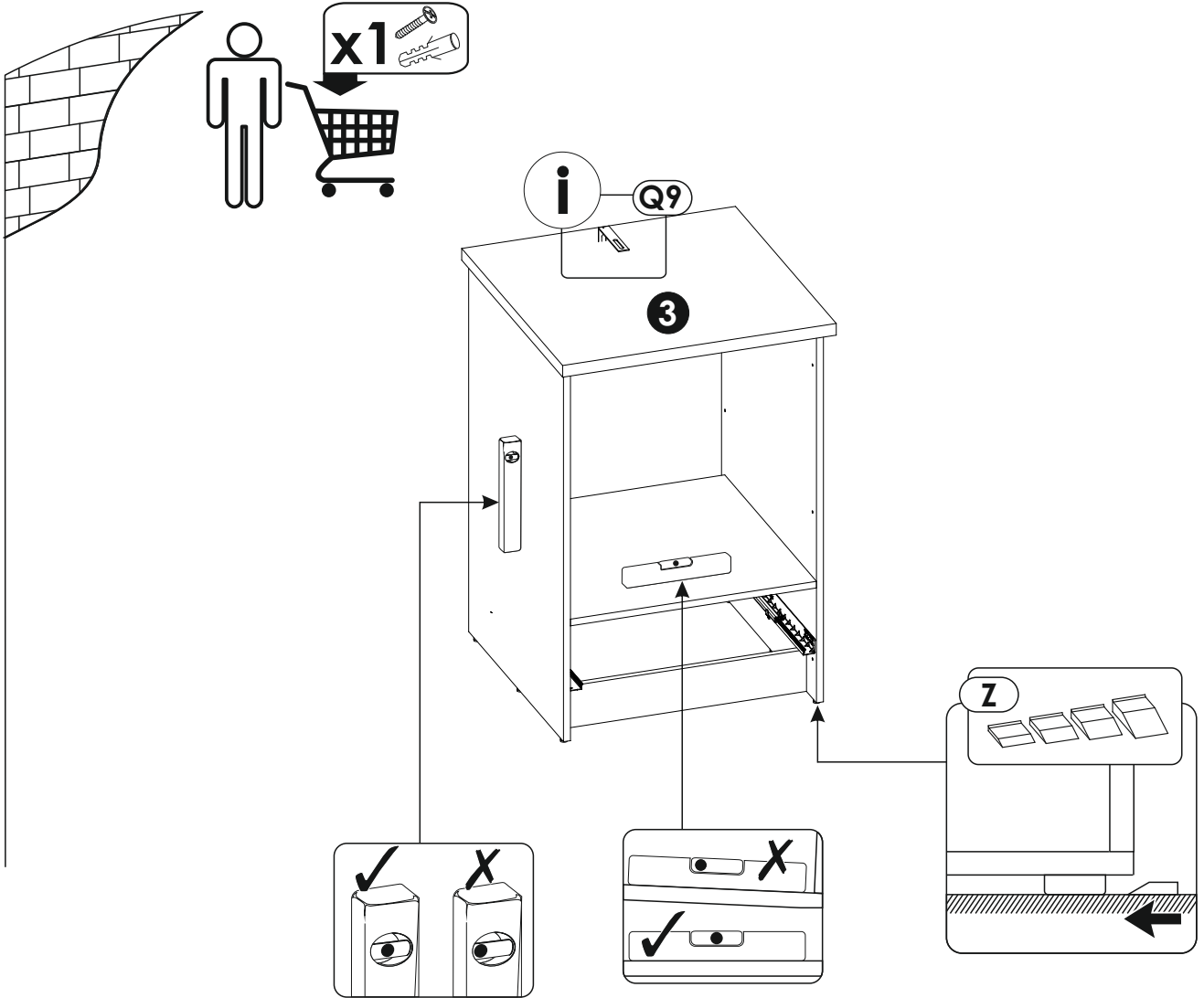
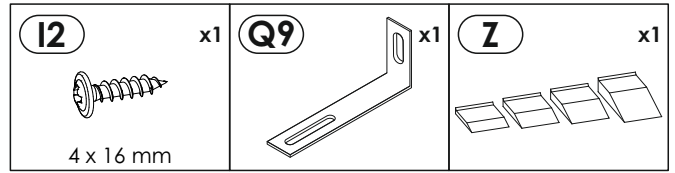
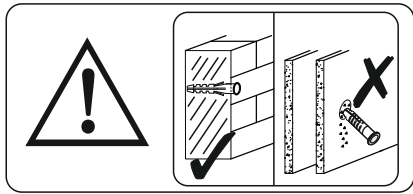

22 ▶

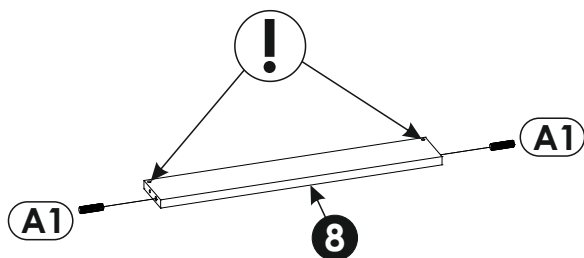
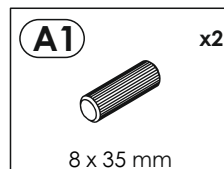
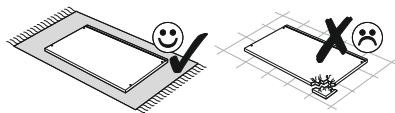

23 ▶

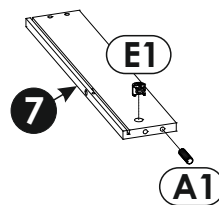
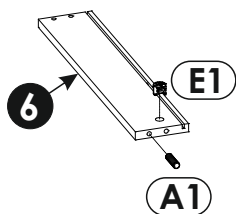
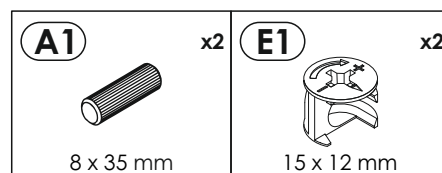
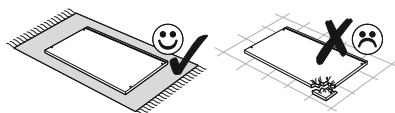

24 ▶

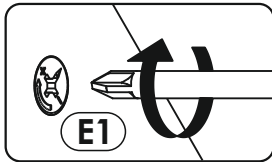
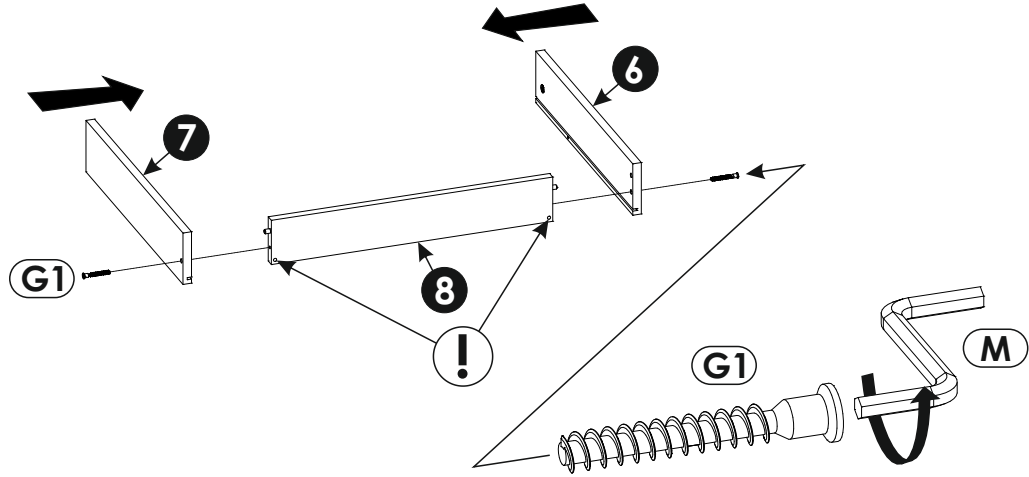
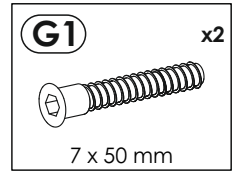
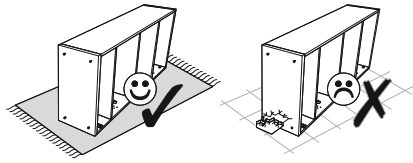

25 ▶

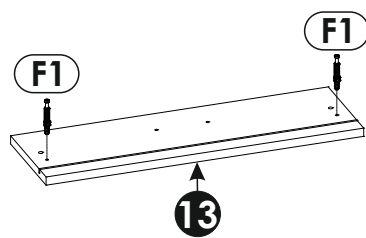
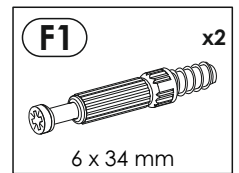
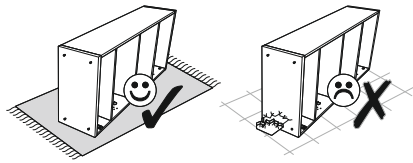

26 ▶

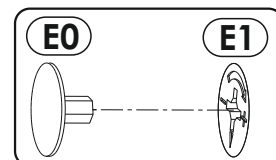
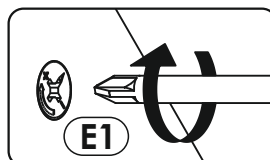
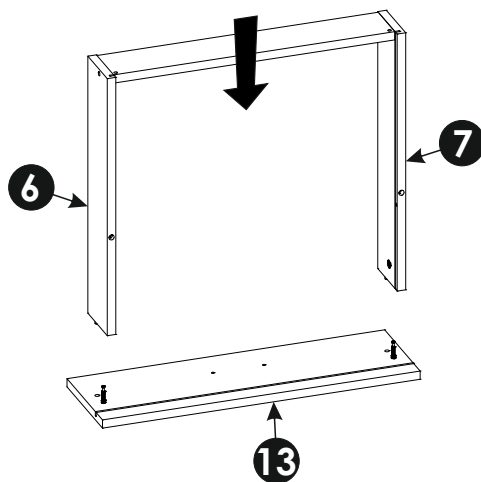
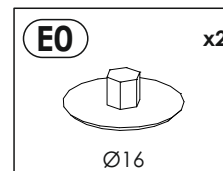
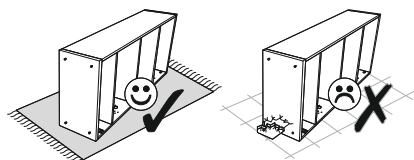

27 ▶

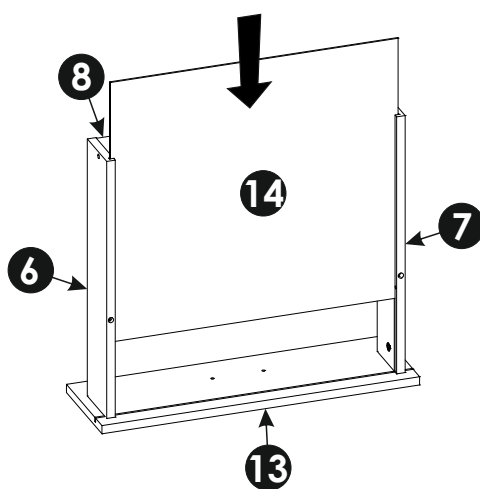
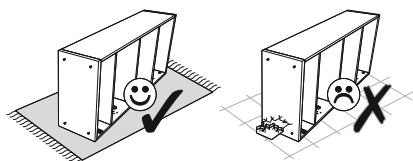

28 ▶

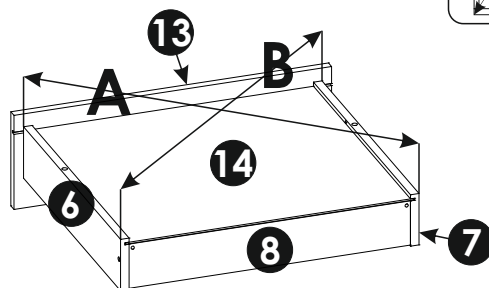
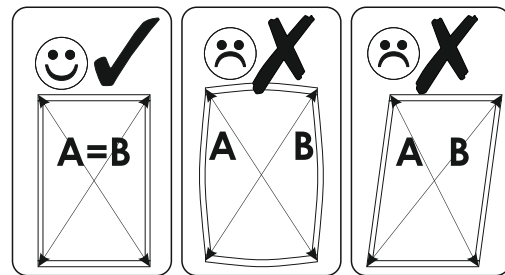
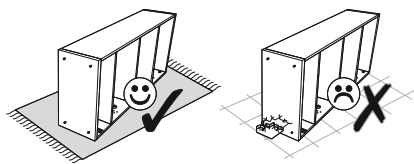

A=B

29 ▶

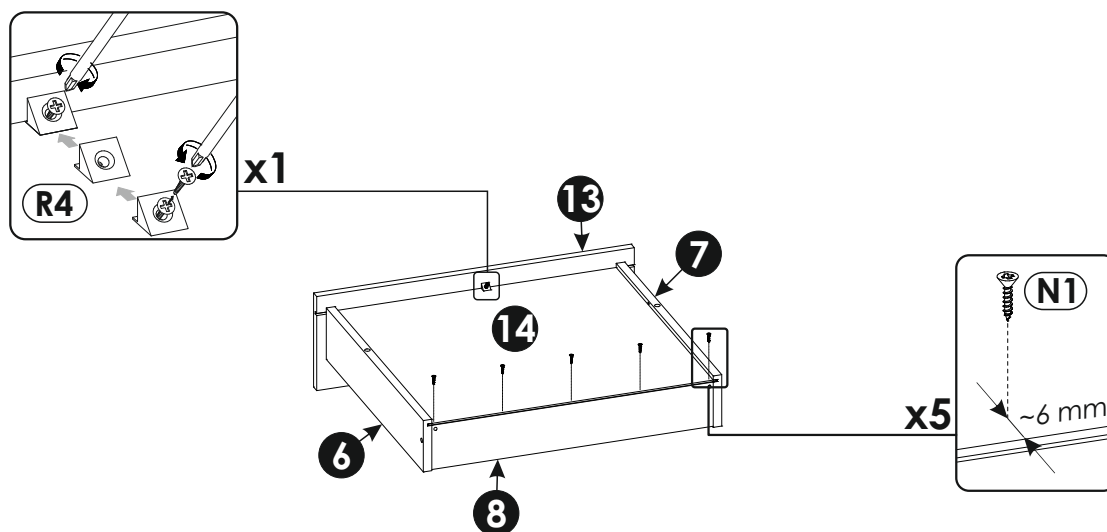
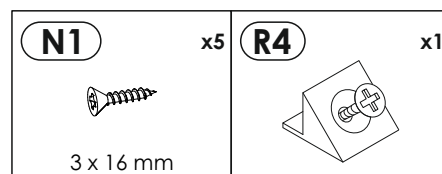
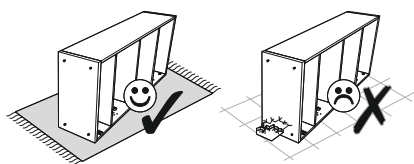

30 ▶

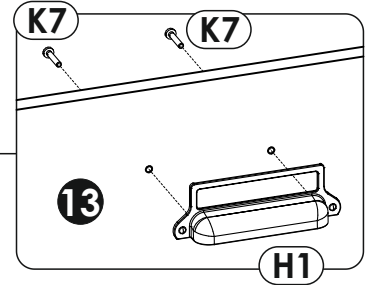
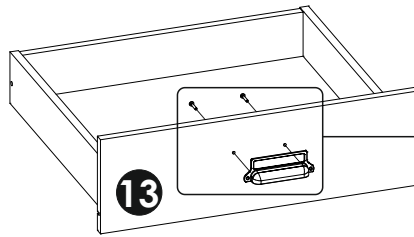
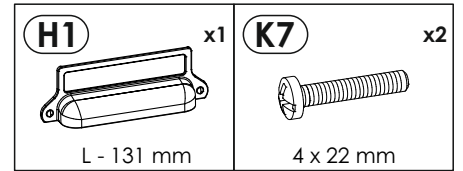
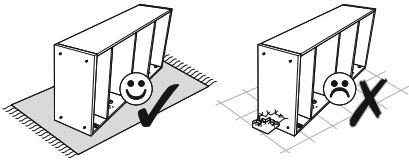

31 ▶

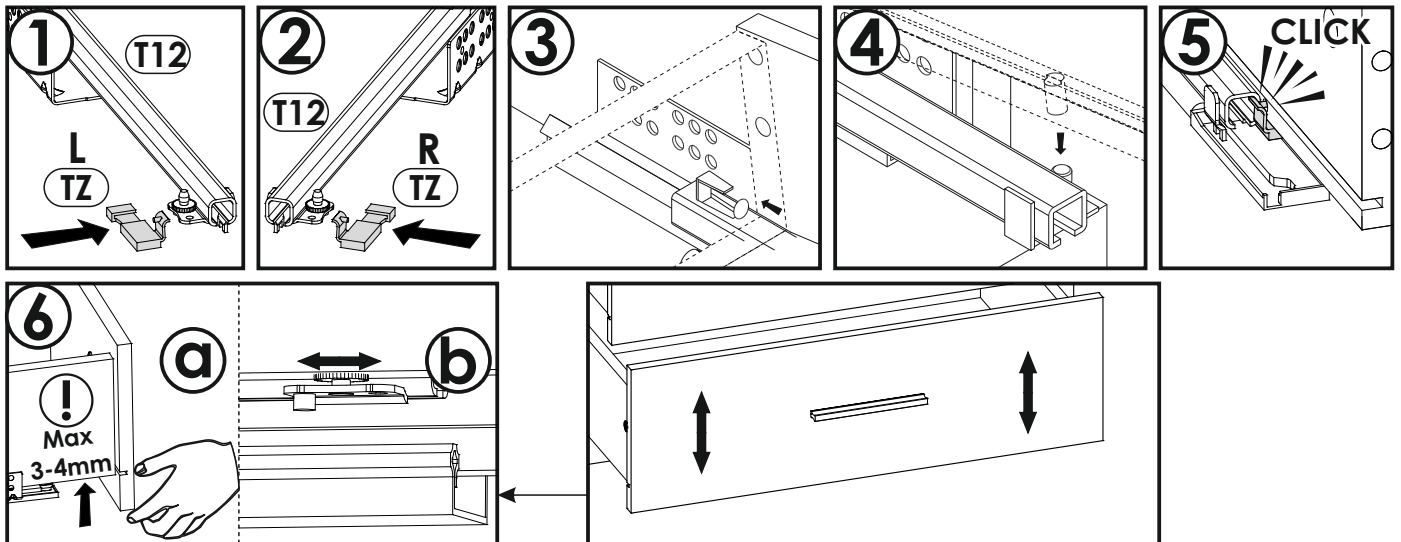
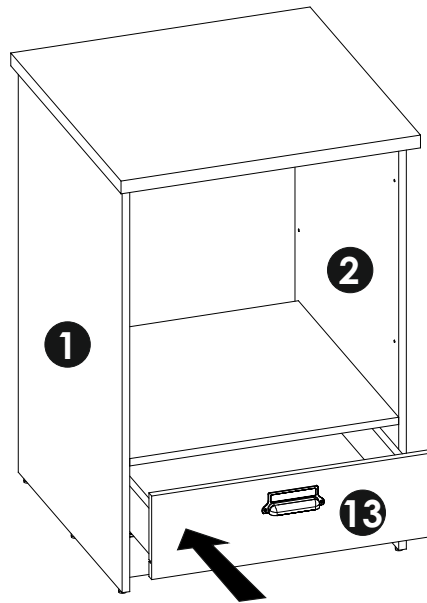

32 ▶

